

FLENDER SIG Standard industrial gear unit

Catalog MD 30.1 · 2011

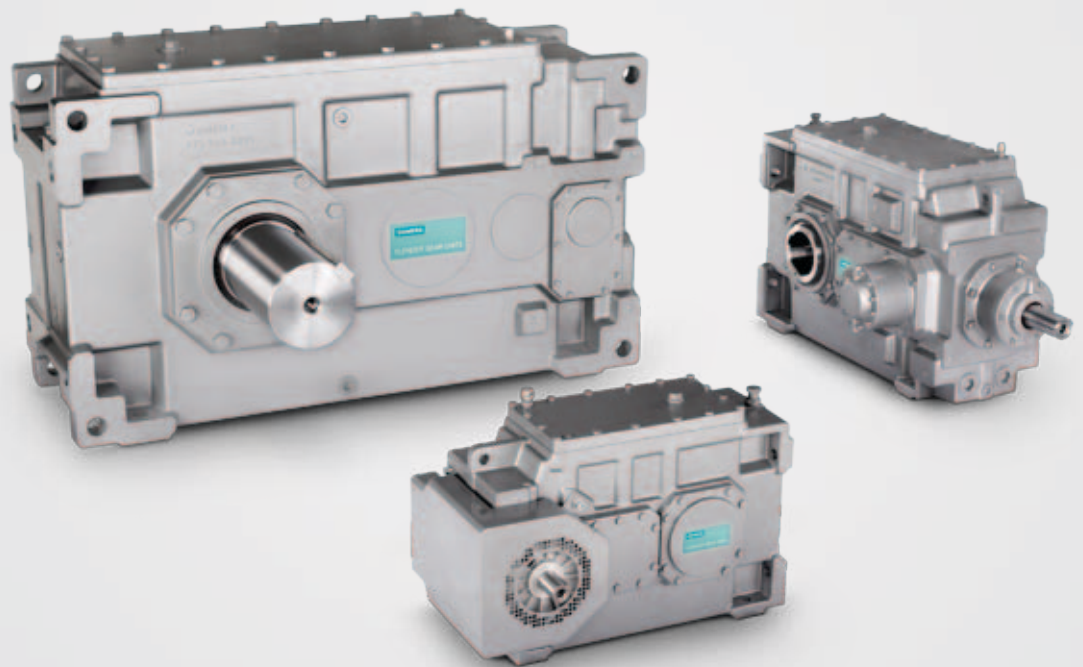

FLENDER gear units

Answers for industry.

SIEMENS

Related catalogs

FLENDER Couplings MD 10.1
Standard couplings

E86060-K5710-A111-A4-7600



ARPEX MD 10.5
Composite Couplings

E86060-K5710-A151-A2-7400



ARPEX MD 10.9
High Performance Couplings

E86060-K5710-A191-A2-7400



ARPEX MD 10.10
Couplings Miniature

E86060-K5710-A211-A2-6300



ARPEX MD 10.11
Torque Limiters

E86060-K5710-A221-A2-7400



Gear Units MD 20.1
Sizes 3–22

E86060-K5720-A111-A2-6300



Gear Units MD 20.11
Sizes 23–28

E86060-K5720-A211-A1-6300



Bucket Elevator Drives MD 20.2

E86060-K5720-A121-A2-6300



PLANUREX 2 MD 20.3
Planetary Gear Units

E86060-K5720-A131-A2-6300

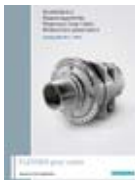

Girth Gear Units MD 20.4
for Tube Mills

E86060-K5720-A141-A1-7400



Paper Machine Drives MD 20.5

E86060-K5720-A151-A1-6300



Conveyor Drives MD 20.6

E86060-K5720-A161-A2-6300



Marine Reduction Gearboxes MD 20.7

E86060-K5720-A171-A1-7400



Products for Automation and Drives CA 01

DVD: E86060-D4001-A510-C9-7600

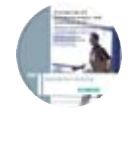

Mall
Information and ordering platform
in the Internet:

www.siemens.com/industrymall



FLENDER gear units

FLENDER SIG

Standard industrial gear unit

Catalog MD 30.1 · 2011



The products and systems listed in this catalog are manufactured and marketed using a certified quality management system complying with DIN EN ISO 9001 (Certificate Registration No. 01 100 000708). The certificate is recognized in all IQNet countries.

© Siemens AG 2011

Introduction	1
Technical information	2
Design of the gear units	3
Helical gear units horizontal mounting position	4
Bevel-helical gear units horizontal mounting position	5
Connection dimensions	6
Options for operation	7
Motor connection	8
Appendix	9



Answers for industry.

The central task in drive engineering is to optimize interoperation of the controller, frequency converter, motor, coupling and gear unit. Through many years of system expertise, well-proven, standardized and reliable solutions have been available from Siemens over the long term. During the development of the new FLENDER SIG series of industrial gear units the main focus of the design engineers was also on the drive train.

FLENDER SIG offers a number of innovative features: Up to 15 % more torque than the highly developed Flender gear units is really impressive. The new series is extremely versatile, and suitable for use in numerous applications. It offers a high degree of flexibility in system planning and many advantages in daily operation. Further benefits are the extended standards for add-on parts and peripherals as well as an additional mounting surface.

Various different cooling solutions are also available as options for FLENDER SIG. The harmonized torque stages mean that you will be closer to your desired torque across the entire spectrum, with positive effects on costs and logistics.

The FLENDER SIG product range is extensive even now. This catalog will provide you with an overview.

Introduction

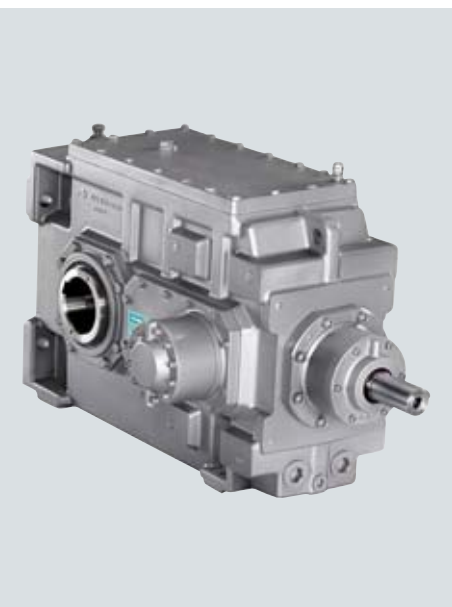

1/2

1/2

1/3

1/3

Notes

Summary of basic types

Characteristic features

Notes on selection and operation

Introduction

Notes

Summary of basic types

1

Overview

Horizontal mounting position

Helical gear units

Types H2..., H3..., H4..

2- ... 4-stage, $i_N = 6.3 - 400$

H.SH

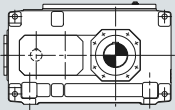

G_MD30_XX_00060

H.HH

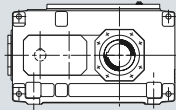

G_MD30_XX_00061

H.DH

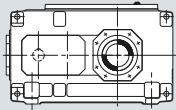

G_MD30_XX_00062

Bevel-helical gear units

Types B3..., B4..

3- ... 4-stage, $i_N = 14 - 355$

B.SH

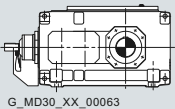

G_MD30_XX_00063

B.HH

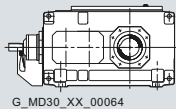

G_MD30_XX_00064

B.DH

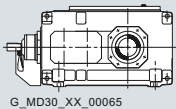

G_MD30_XX_00065

Structure of types

Type		B	3	S	H
Type	Helical gear unit	H			
	Bevel-helical gear unit	B			
No. of stages	2		2		
	3			3	
	4				4
Output shaft design	Solid shaft			S	
	Hollow shaft with keyway to DIN 6885/1				H
	Hollow shaft for shrink disk				D
Mounting	Horizontal				H

Structure of gear unit size

Gear unit size		5	1	1
Gear unit size	• 504	5	0	4
	• 505	5	0	5
	• 506	5	0	6
	• 507	5	0	7
	• 508	5	0	8
	• 509	5	0	9
	• 510	5	1	0
	• 511	5	1	1
	• 512	5	1	2
	• 513	5	1	3
	• 514	5	1	4

Further details required in orders

- Transmission ratio i
- Designs A, B, C, D, etc.

Example B3SH 511

- Bevel-helical gear unit, 3-stage
- Design A
- $i = 16$
- Solid output shaft design
- Horizontal mounting position
- Size 511

Overview**Characteristic features**Design

FLENDER SIG gear units are a completely new design. Advantages are:

- Even more torque for the same size
- Even greater flexibility through additional mounting positions
- Even greater plant availability thanks to longer rolling bearing service life
- Even closer to the customer's desired torque thanks to considerably harmonized torque stages
- Wide range of variants from 5 types with solid shaft or different hollow shaft designs
- Available, if required, with dust-tight taconite seals
- Internal cooling or standardized fan mounting, as required
- Fast availability worldwide
- Attractive price/performance ratio
- Higher operational reliability combined with increased power density

Mounting position

- FLENDER SIG gear units are available for horizontal installation.
- Other arrangements are also possible on request. The basic gear unit can be optimally adapted to customer requirements by fitting different add-on pieces like motor bell housings, gear unit swing-bases or backstops.

Noise behavior

New concepts were applied to clearly improve the noise emission of the FLENDER SIG gear units by

- Grinding the bevel gears
- Optimizing the wheel set
- Developing a compact monoblock housing
- Achieving exceptionally large contact ratios.

Thermal conduction

FLENDER SIG gear units not only have a high efficiency but also a favorable thermal conduction

- Through enlarged housing surface areas
- Because large fans incorporating a new type of air conduction fan cowl are being used.

The selection of gear units is based on a lower maximum oil temperature. By that, the operational reliability will be increased and the cost of maintenance reduced due to longer oil change intervals.





Storing

FLENDER SIG gear units have been designed according to a new unit construction principle. Through this, the variety of parts could be reduced. The parts are mainly on stock enabling the Siemens manufacturing plants worldwide to deliver at short term.

Overview**Notes on selection and operation**

- Illustrations are examples only and are not strictly binding. Dimensions are subject to change.
- The weights are mean values and not strictly binding.
- To prevent accidents, all rotating parts should be guarded according to local and national safety regulations.
- Prior to commissioning, the operating instructions must be observed. The gear units are delivered ready for operation but without oil filling.
- Oil quantities given are guide values only. The exact quantity of oil depends on the marks on the oil dipstick.
- The oil viscosity has to correspond to the data given on the name plate.
- Approved lubricants may be used only. You will find current operating instructions and lubricant selection tables on the Internet at: <http://support.automation.siemens.com/WW/view/en/44231658>
- The gear units are supplied with radial shaft seals. Other sealing variants are available on request.
- Directions of rotation refer to the output shaft d_2 .
- In case of outdoor installation, insulation is to be avoided. The customer has to provide adequate protection.

Explanation of symbols used in the dimensioned drawings:

Symbol	Explanation
	Oil dipstick
	Breather
	Oil drain
	Oil filler

Foundation bolts of min. property class 8.8. Tolerance of the clearance holes in the housing acc. to DIN EN 20273 - "coarse" series. The gear housings are protected against corrosion and lacquered in the color RAL 5015.

Certified acc. to DIN EN ISO 9001

Introduction

Notes

1

Technical information



2/2	Preservation
2/2	Selection of oil
2/2	Maintenance
2/2	Shaft misalignment

Preservation, selection of oil, maintenance, shaft misalignment

Overview

Preservation

The internal preservation of Siemens gear units is dependent on the oil used.

For gear units with corrosion prevention, the following storage times are possible:

Standard preservation	Long-term preservation ¹⁾
Up to 6 months	Up to 24 months ²⁾
	Up to 36 months ³⁾

If the storage periods mentioned are exceeded, the anti-corrosive agent in the gear unit is to be renewed.

Selection of oil

Siemens industrial gear units may be filled with oils from producers authorized by Siemens AG, the oil producer or supplier being responsible for the quality of the product. For the selection of oil grade and viscosity, the limits of application given in the table are to be taken into consideration.

A minimum operating viscosity of 25 cSt must be ensured.

Viscosity ISO-VG at 40 °C in mm ² /s (cSt)	Minimum temperature limit in °C for dip lubrication	
	Mineral oil	Synthetic oil
VG 220	-15	-25
VG 320	-12	-25
VG 460	-10	-25

Dip lubrication:

In case of dip lubrication, all parts to be lubricated are lying in the oil.

If the temperatures are below the values as listed in the table, the oil must be heated.

In case of dip lubrication, the oil temperature must not drop below the pour point of the selected oil.

Maintenance

Compliance with the conditions for operation and installation is essential. To prevent damage to the gear unit or failure of the drive, regular inspection and maintenance must be performed as specified in the operating instructions.

Shaft misalignment

Shaft misalignment is the result of displacement during assembly and operation and, where machines constructed with two radial bearings each are rigidly coupled, will cause high loads being placed on the bearings. Elastic deformation of base frame, foundation and machine housing will lead to shaft misalignment which cannot be prevented, even by precise alignment. Furthermore, because individual components of the drive train heat up differently during operation, heat expansion of the machine housings causes shaft misalignment.

Poorly aligned drives are often the cause of seal or rolling bearing failure. Alignment should be carried out by specialist personnel in accordance with Siemens operating instructions.

Depending on the direction of the effective shaft misalignment a distinction is made between:

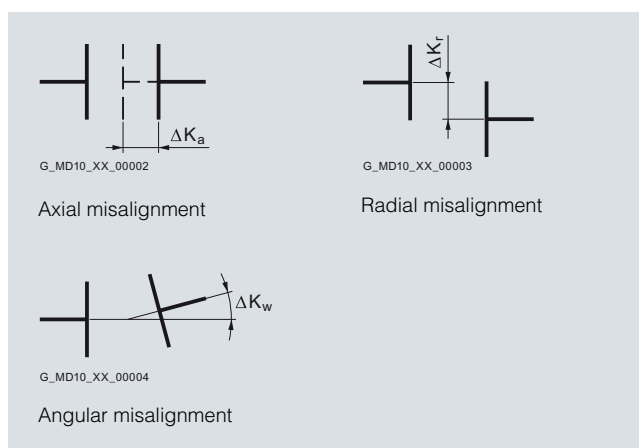

The shaft misalignment expected must be taken into account on selecting the connection between the components and the input shaft or output shaft. Guidelines and limits for compensation of shaft misalignment can be obtained from the manufacturer.

¹⁾ Not for gear units with labyrinth seals or diaphragm glands.

²⁾ Only if mineral oil or synthetic oil on PAO basis is used.

³⁾ Only if synthetic oil on PG basis is used.

Design of the gear units



Guidelines for selection

- 3/2 Constant mechanical power rating
- 3/4 Variable power rating
- 3/5 Key to symbols
- 3/6 Calculation example
- 3/8 Service factors

Overview tables

- 3/10 Type H2
- 3/16 Type H3
- 3/22 Type H4
- 3/26 Type B3
- 3/32 Type B4
- 3/36 Actual ratio H2, H3, H4
- 3/37 Actual ratio B3, B4

Design of the gear units

Guidelines for selection

Constant mechanical power rating

Overview

1. Determination of gear unit type and size

1.1 Find the transmission ratio

$$i_s = \frac{n_1}{n_2}$$

1.2 Determine the nominal power rating of the gear unit

$$P_{2N} \geq P_2 \times f_1 \times f_2$$

It is not necessary to consult us, if:

$$3.33 \times P_2 \geq P_{2N}$$

1.3 Check the maximum torque

e.g.: peak operating, starting or braking torque

$$P_{2N} = \frac{T_A \times n_1}{9550} \times f_3$$

Gear unit sizes and number of reduction stages are given in rating tables depending on i_N and P_{2N} .

1.4 Check whether additional forces on the output shaft are permissible; it is essential to consult Siemens!

1.5 Check whether the actual ratio i as per tables on pages 3/36, 3/37 is acceptable

2. Determination of oil supply: Horizontal mounting position

All parts to be lubricated are lying in the oil or are splash lubricated. Forced lubrication on request.

Constant mechanical power rating

Overview (continued)

3. Determination of required thermal capacity P_G

Data required: <ul style="list-style-type: none"> Type Size Nominal ratio Ambient temperature Input speed (1000/1500/1800 rpm) 	For the calculation below, the following has been assumed: <ul style="list-style-type: none"> Gear unit with dip lubrication Operating cycle: 100 % Installation in a large hall (wind velocity ≥ 1.4 m/s) altitude up to 1000 m Gear unit with mineral oil ISO-VG460
--	--

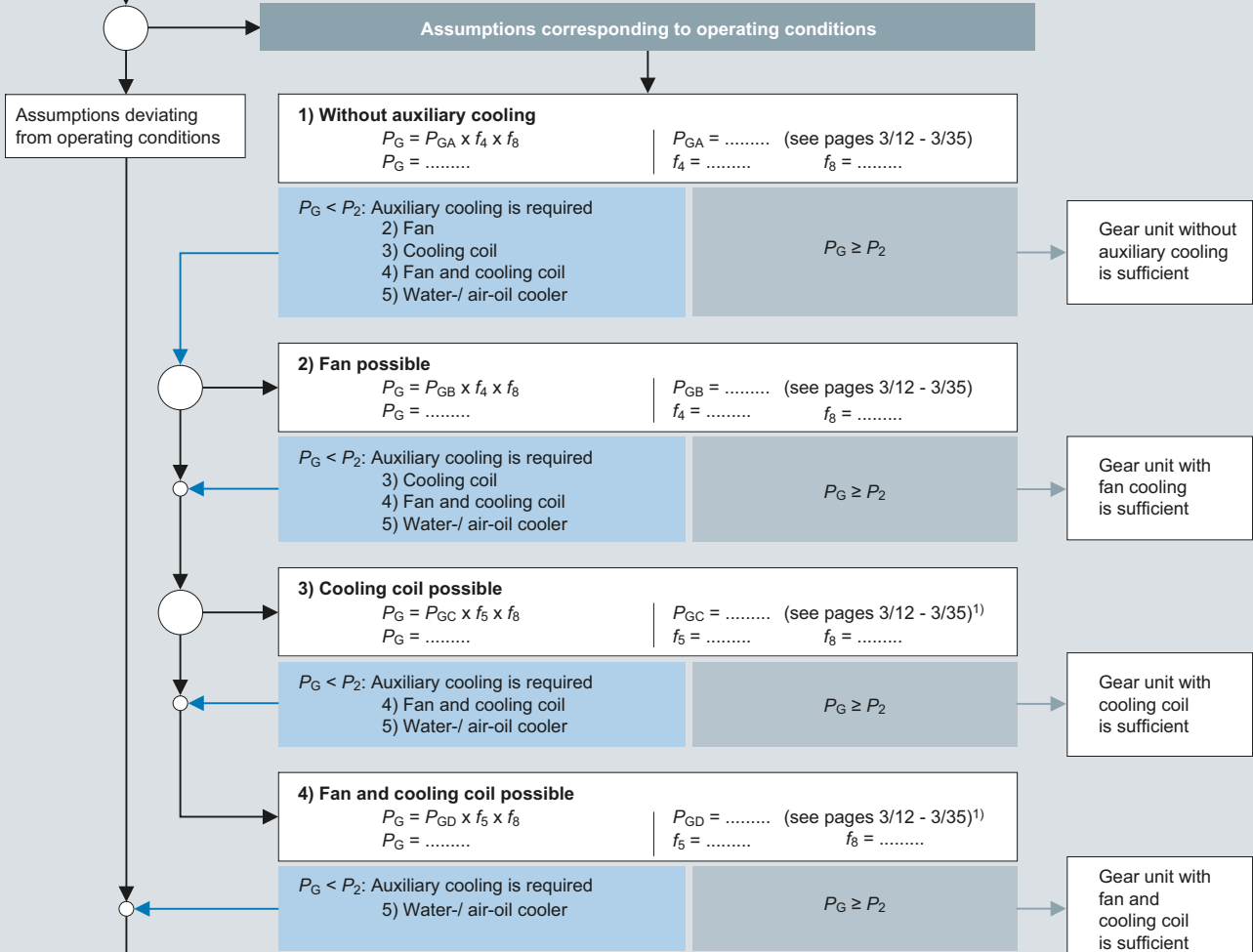

¹⁾ Values refer to a cooling water inlet temperature of 20 °C!

Recalculation with other assumptions: <ul style="list-style-type: none"> "X.CAT-NG" 	$P_G < P_2$ → Please consult the sales person responsible Variation of the following items is possible: <ul style="list-style-type: none"> Oil grade / viscosity / level Gear unit on foundation or shaft-mounted gear unit Application of an oil supply system ... 	$P_G \geq P_2$ → Gear unit with selected cooling is sufficient
---	--	--

The type of the possibly required auxiliary cooling is dependent on the operating conditions at the customer site (dust, cooling water connection, etc.)

G_MD30_EN_00048

Design of the gear units

Guidelines for selection

Variable power rating

Overview

For driven machines with constant speeds and variable power ratings the gear unit can be designed according to the equivalent power rating. For this a working cycle where phases I, II...n require power $P_I, P_{II} \dots P_n$ and the respective power ratings operate for time fractions $X_I, X_{II} \dots X_n$ is taken as a basis. The equivalent power rating can be calculated from these specifications with the following formula:

$$P_{2eq} = \sqrt[6.6]{P_I^{6.6} \times \frac{X_I}{100} + P_{II}^{6.6} \times \frac{X_{II}}{100} + \dots + P_n^{6.6} \times \frac{X_n}{100}}$$

The size of the gear unit can then be determined analogously to points 1.1 ... 1.5 and 3.

The following applies:

$$P_{2N} \geq P_{2eq} \times f_1 \times f_2$$

Then, when P_{2N} has been determined, the power and time fractions must be checked by applying the following requirements:

- The individual power fractions $P_I, P_{II} \dots P_n$ must be greater than $0.4 \times P_{2N}$.
- The individual power fractions $P_I, P_{II} \dots P_n$ must not exceed $1.4 \times P_{2N}$.
- If power fractions $P_I, P_{II} \dots P_n$ are greater than P_{2N} , the sum of time fractions $X_I, X_{II} \dots X_n$ must not exceed 10 %.

If any one of the three requirements is not met, P_{2eq} must be recalculated.

It must be borne in mind that a brief peak power rating not included in the calculation of P_{2eq} must not be greater than $P_{max} = 2 \times P_{2N}$.

In applications where the torque is variable but the speed constant, the gear unit can be designed on the basis of the so-called equivalent torque.

A gear unit design which is finite-life fatigue-resistant can be sufficient for certain applications, for example, sporadic operation (lockgate drives) or low output speeds ($n_2 < 4$ rpm).

Example: Service classification

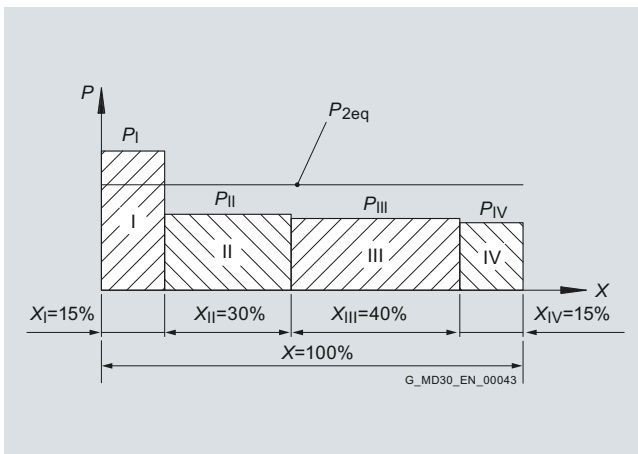

Overview

Key to symbols

Description	Explanation	Chapter/Page
E_D	Operating cycle per hour in % (e.g. $E_D = 80$ % per hour)	
f_1	Factor for driven machine	3/8
f_2	Factor for prime mover	3/9
f_3	Peak torque factor	3/9
f_4	Thermal factors	3/9
f_5	Thermal factors	3/9
f_8	Oil supply factor	3/9
i	Actual ratio	3/36, 3/37
i_N	Nominal ratio	
i_s	Required ratio	
n_1	Input speed (rpm)	
n_2	Output speed (rpm)	
P_G	Required thermal capacity	3/3
P_{GA}	Thermal capacity for gear units without auxiliary cooling	
P_{GB}	Thermal capacity for gear units with fan cooling	
P_{GC}	Thermal capacity for gear units with built-in cooling coil	
P_{GD}	Thermal capacity for gear units with built-in cooling coil and fan	
P_{2N}	Nominal power rating of gear unit (kW), see rating tables	
P_2	Power rating of driven machine (kW)	
t	Ambient temperature (°C)	
T_A	Max. torque occurring on input shaft, e.g. peak operating, starting, or braking torque (Nm)	
T_{2N}	Nominal output torque (kNm)	
P_{2eq}	Equivalent power rating (kW)	
P_f, P_{II}, P_n	Fractions of power rating (kW) obtained from service classification	
X_f, X_{II}, X_n	Fractions of time (%) obtained from service classification	

Notes and legend for tables of thermal capacities

* On request

P_{GA} (kW):
Gear units without auxiliary cooling;
Values refer to:
Operating cycle 100 %,
Installation in a large hall,
Altitude up to 1000 m

P_{GB} (kW):
Gear units with fan;
Values refer to:
Operating cycle 100 %,
Installation in a large hall,
Altitude up to 1000 m

P_{GC} (kW):
Gear units with built-in cooling coil;
Values refer to:
Operating cycle 100 %,
Installation in a large hall,
Altitude up to 1000 m,
Cooling water inlet temperature of 20 °C with
unlimited cooling water outlet temperature.
A recalculation with a limited cooling water outlet temperature is possible on request.

P_{GD} (kW):
Gear units with fan and built-in cooling coil;
Values refer to:
Operating cycle 100 %,
Installation in a large hall,
Altitude up to 1000 m,
Cooling water inlet temperature of 20 °C with
unlimited cooling water outlet temperature.
A recalculation with a limited cooling water outlet temperature is possible on request.

Design of the gear units

Guidelines for selection

Calculation example

Overview

Known criteria for the calculation example

Prime mover

- Electric motor $P_1 = 75 \text{ kW}$
- Motor speed: $n_1 = 1500 \text{ rpm}$
- Max. starting torque: $T_a = 720 \text{ Nm}$

Driven machine

- Belt conveyor: $P_2 = 66 \text{ kW}$
- Speed: $n_2 = 26 \text{ rpm}$
- Duty: 12 h/day
- Starts per hour: 7
- Operating cycle per hour: $E_D = 100 \%$
- Ambient temperature: 30 °C
- Installation in a large hall: Wind velocity $\geq 1.4 \text{ m/s}$
- Altitude: Sea level

Gear unit design

- Bevel-helical gear unit
- Mounting position: Horizontal
- Output shaft d_2 : On right-hand side, design C, solid shaft
- Direction of rotation of output shaft d_2 : ccw

Required:

- Type of gear unit
- Gear unit size

1. Determination of gear unit type and size

1.1 Find the transmission ratio

$$i_s = \frac{n_1}{n_2} = \frac{1500}{26} = 57.7 \quad i_N = 56$$

1.2 Determine the nominal power rating of the gear unit

$$P_{2N} \geq P_2 \times f_1 \times f_2 = 66 \times 1.3 \times 1 = 85.8 \text{ kW}$$

Selected from power rating table: type B3SH, gear unit size 509 with $P_{2N} = 102 \text{ kW}$.

$$3.33 \times P_2 \geq P_{2N} \quad 3.33 \times 66 = 219.8 \text{ kW} > P_{2N}$$

It is not necessary to consult us

1.3 Check the starting torque

$$P_{2N} \geq \frac{T_A \times n_1}{9550} \times f_3 = \frac{720 \times 1500}{9550} \times 0.65 = 73.5 \text{ kW}$$

$$P_{2N} = 102 \text{ kW} > 73.5 \text{ kW}$$

2. Determination of oil supply

Gear unit with dip lubrication

Overview (continued)

3. Determination of required thermal capacity P_G

<p>Data required:</p> <ul style="list-style-type: none"> Type: B3SH Size: 509 Nominal ratio: $i_N = 56$ Ambient temperature: $t = 30\text{ °C}$ Input speed $n_1 = 1500\text{ rpm}$ 	<p>For the calculation below, the following has been assumed:</p> <ul style="list-style-type: none"> Gear unit with dip lubrication Operating cycle: 100 % Installation in a large hall (wind velocity $\geq 1.4\text{ m/s}$ altitude up to 1000 m) Gear unit with mineral oil ISO-VG460
--	--

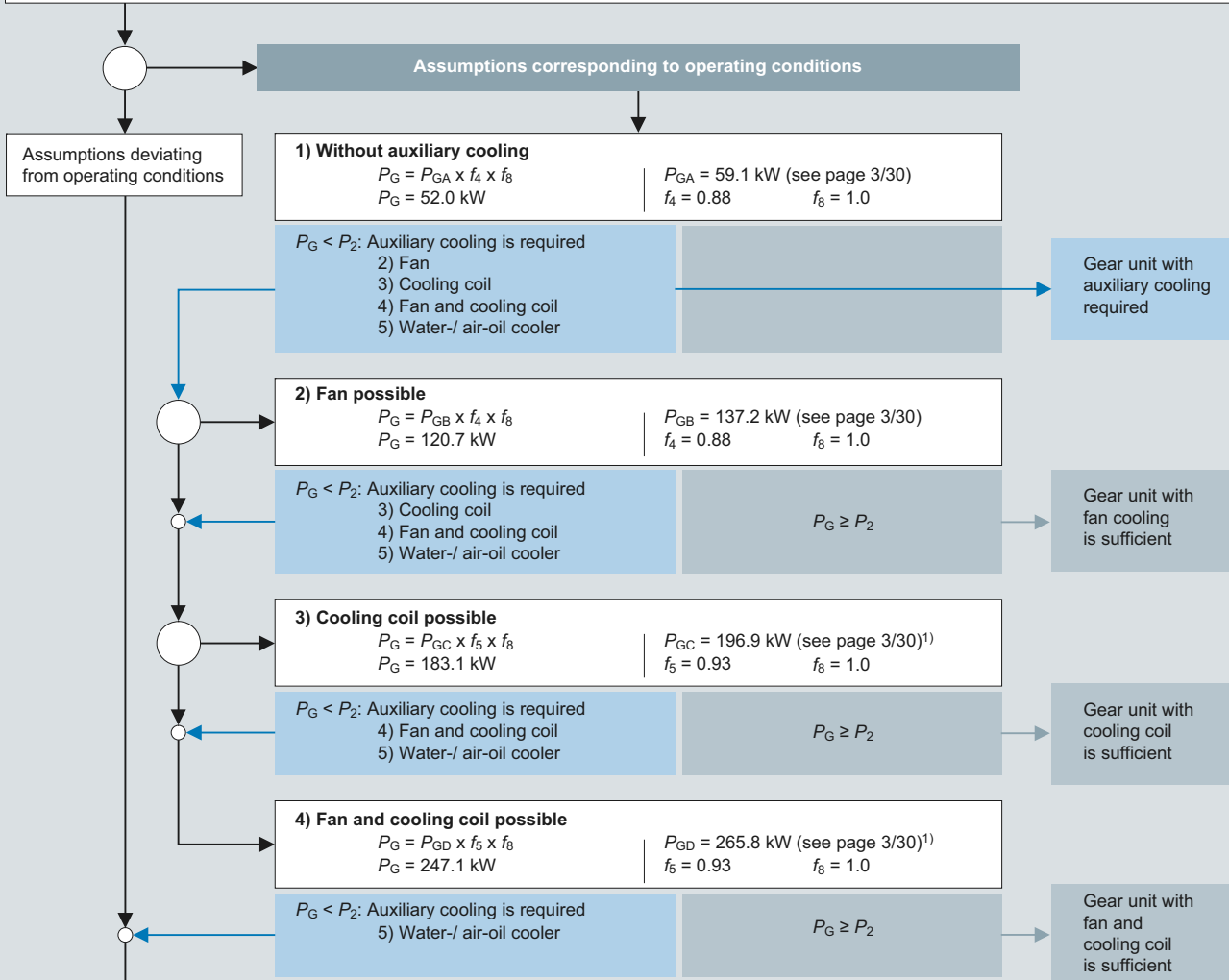

¹⁾ Values refer to a cooling water inlet temperature of 20 °C!

<p>Recalculation with other assumptions:</p> <ul style="list-style-type: none"> "X.CAT-NG" 	<p>$P_G < P_2$</p> <p>$P_G \geq P_2$</p>	<p>Please consult the sales person responsible</p> <p>Variation of the following items is possible:</p> <ul style="list-style-type: none"> Oil grade / viscosity / level Gear unit on foundation or shaft-mounted gear unit Application of an oil supply system ...
--	---	--

Gear unit with selected cooling is sufficient

The selected gear unit B3SH509 with $i_N = 56$ must be equipped with suitable auxiliary cooling. Depending on the operating conditions at the customer site, a fan or cooling coil must be fitted.

G_MD30_EN_00049

Design of the gear units

Guidelines for selection

Service factors

Overview

Factor for driven machines f_1

Driven machines	Effective operating period under load in hours		
	≤ 0.5	> 0.5 – 10	> 10
Waste water treatment			
• Thickeners (central drive)	–	–	1.2
• Filter presses	1.0	1.3	1.5
• Flocculation apparatus	0.8	1.0	1.3
• Aerators	–	1.8	2.0
• Raking equipment	1.0	1.2	1.3
• Combined longitudinal and rotary rakes	1.0	1.3	1.5
• Pre-thickeners	–	1.1	1.3
• Screw pumps	–	1.3	1.5
• Water turbines	–	–	2.0
<u>Pumps</u>			
• Centrifugal pumps	1.0	1.2	1.3
• Positive-displacement pumps			
- 1 piston	1.3	1.4	1.8
- > 1 piston	1.2	1.4	1.5
Dredgers			
• Bucket conveyors	–	1.6	1.6
• Dumping devices	–	1.3	1.5
• Caterpillar traveling gears	1.2	1.6	1.8
<u>Bucket wheel excavators</u>			
- as pick-up	–	1.7	1.7
- for primitive material	–	2.2	2.2
• Cutter heads	–	2.2	2.2
• Slewing gears ¹⁾	–	1.4	1.8
Plate bending machines ¹⁾			
–	–	1.0	1.0
Chemical Industry			
• Extruders	–	–	1.6
• Dough mills	–	1.8	1.8
• Rubber calenders	–	1.5	1.5
• Cooling drums	–	1.3	1.4
<u>Mixers for</u>			
- uniform media	1.0	1.3	1.4
- non-uniform media	1.4	1.6	1.7
<u>Agitators for media with</u>			
- uniform density	1.0	1.3	1.5
- non-uniform density	1.2	1.4	1.6
- non-uniform gas absorption	1.4	1.6	1.8
• Toasters	1.0	1.3	1.5
• Centrifuges	1.0	1.2	1.3
Metal working mills			
• Plate tilters	1.0	1.0	1.2
• Ingot pushers	1.0	1.2	1.2
• Winding machines	–	1.6	1.6
• Cooling bed transfer frames	–	1.5	1.5
• Roller straighteners	–	1.6	1.6
<u>Roller tables</u>			
- continuous	–	1.5	1.5
- intermittent	–	2.0	2.0
• Reversing tube mills	–	1.8	1.8
<u>Shears</u>			
- continuous ¹⁾	–	1.5	1.5
- crank type ¹⁾	1.0	1.0	1.0
• Continuous casting drivers ¹⁾	–	1.4	1.4

Driven machines	Effective operating period under load in hours		
	≤ 0.5	> 0.5 – 10	> 10
Rolls			
- Reversing blooming mills	–	2.5	2.5
- Reversing slabbing mills	–	2.5	2.5
- Reversing wire mills	–	1.8	1.8
- Reversing sheet mills	–	2.0	2.0
- Reversing plate mills	–	1.8	1.8
• Roll adjustment drives	0.9	1.0	–
Conveyors			
• Bucket conveyors	–	1.4	1.5
• Hauling winches	1.4	1.6	1.6
• Hoists	–	1.5	1.8
• Belt conveyors ≤ 150 kW	1.0	1.2	1.3
• Belt conveyors ≥ 150 kW	1.1	1.3	1.4
• Goods lifts ¹⁾	–	1.2	1.5
• Passenger lifts ¹⁾	–	1.5	1.8
• Apron conveyors	–	1.2	1.5
• Escalators	1.0	1.2	1.4
• Railway vehicles	–	1.5	–
Frequency converters			
–	–	1.8	2.0
Reciprocating compressors			
–	–	1.8	1.9
Cranes ²⁾			
• Slewing gears ¹⁾	1.0	1.4	1.8
• Luffing gears	1.0	1.1	1.4
• Traveling gears	1.1	1.6	2.0
• Hoisting gears	1.0	1.1	1.4
• Derricking jib cranes	1.0	1.2	1.6
Cooling towers			
• Cooling tower fans	–	–	2.0
• Blowers (axial and radial)	–	1.4	1.5
Food industry			
<u>Cane sugar production</u>			
• Cane knives ¹⁾	–	–	1.7
• Cane mills	–	–	1.7
<u>Beet sugar production</u>			
• Beet cosettes macerators	–	–	1.2
• Extraction plants, mechanical refrigerators	–	–	1.4
• Juice boilers, sugar beet washing machines	–	–	1.5
• Sugar beet cutters	–	–	–
Paper machines			
• of all kinds ³⁾	–	1.8	2.0
• Pulper drives (on request)	–	–	–
Centrifugal compressors			
–	–	1.4	1.5
Cableways			
• Material ropeways	–	1.3	1.4
• To-and-fro system aerial ropeways	–	1.6	1.8
• T-bar lifts	–	1.3	1.4
• Continuous ropeways	–	1.4	1.6
Cement industry			
• Concrete mixers	–	1.5	1.5
• Breakers ¹⁾	–	1.2	1.4
• Rotary kilns	–	–	2.0
• Tube mills	–	–	2.0
• Separators	–	1.6	1.6
• Roll crushers	–	–	2.0

Note: The listed load parameters are empirical values. Prerequisite for their application is that the machinery and equipment mentioned correspond to generally accepted design and load specifications. In case of deviations from standard conditions, please contact us. For driven machines which are not listed in this table, please refer to us.

Design for power rating of driven machine P_2

¹⁾ Designed power corresponding to max. torque

²⁾ Load can be exactly classified, for instance, according to FEM 1001

³⁾ A check for thermal capacity is absolutely essential

Overview (continued)**Factor for prime mover f_2**

	Factor for prime mover f_2
Electric motors, hydraulic motors, turbines	1.0
Piston engines 4 - 6 cylinders, cyclic variation 1 : 100 to 1 : 200	1.25
Piston engines 1 - 3 cylinders cyclic variation 1 : 100	1.5

Peak torque factor f_3

	Peak torque factor f_3			
	Load peaks per hour			
	1 - 5	6 - 30	31 - 100	> 100
Steady direction of load	0.5	0.65	0.7	0.85
Alternating direction of load	0.7	0.95	1.10	1.25

Thermal factor f_4

(Gear units without auxiliary cooling or with fan)

	Ambient temperature								
	10 °C	15 °C	20 °C	25 °C	30 °C	35 °C	40 °C	45 °C	50 °C
Thermal factor f_4	1.11	1.06	1.00	0.94	0.88	0.82	0.75	0.69	0.63

Thermal factor f_5

(For cooling with cooling coil, or with fan and cooling coil)

	Ambient temperature								
	10 °C	15 °C	20 °C	25 °C	30 °C	35 °C	40 °C	45 °C	50 °C
Thermal factor f_5	1.05	1.03	1.00	0.97	0.93	0.90	0.87	0.84	0.81

Oil supply factor f_8

Type of gear unit	Oil supply factor f_8				
	Oil supply	Without auxiliary cooling	With fan	With cooling coil	With fan and cooling coil
• H..H	Dip lubrication	1	1	1	1
• B..H					

Design of the gear units

Overview tables

Type H2
Nominal power ratings, gear unit sizes 504 to 514

Technical data

Nominal power ratings P_{2N} (kW) for H2

i_N	n_1	n_2	Gear unit sizes										
			504	505	506	507	508	509	510	511	512	513	514
6.3	1800	286	208	343	–	648	–	1084	–	1851	–	3037	–
	1500	238	173	286	–	540	–	903	–	1543	–	2531	–
	1200	190	138	229	–	432	–	723	–	1234	–	2024	–
	1000	159	115	191	–	360	–	602	–	1028	–	1687	–
7.1	1800	254	184	311	–	585	–	982	–	1672	–	2733	–
	1500	211	153	259	–	487	–	818	–	1393	–	2277	–
	1200	169	123	207	–	390	–	655	–	1115	–	1822	–
	1000	141	102	173	–	325	–	546	–	929	–	1518	–
8	1800	225	167	270	–	517	672	855	1127	1505	1912	2450	2941
	1500	188	139	225	–	431	560	712	939	1254	1593	2042	2451
	1200	150	111	180	–	345	448	570	751	1003	1274	1634	1961
	1000	125	93	150	–	287	373	475	626	836	1062	1361	1634
9	1800	200	152	244	346	463	607	766	1020	1348	1727	2186	2647
	1500	167	126	204	289	386	505	639	850	1124	1439	1822	2206
	1200	133	101	163	231	309	404	511	680	899	1151	1458	1765
	1000	111	84	136	192	257	337	426	567	749	959	1215	1471
10	1800	180	135	221	314	414	537	683	888	1202	1554	1939	2373
	1500	150	112	184	262	345	447	570	740	1001	1295	1616	1978
	1200	120	90	147	209	276	358	456	592	801	1036	1293	1582
	1000	100	75	123	174	230	298	380	493	668	863	1077	1319
11.2	1800	161	122	195	272	358	480	602	796	1064	1393	1708	2118
	1500	134	101	163	227	298	400	502	664	887	1160	1424	1765
	1200	107	81	130	182	239	320	401	531	709	928	1139	1412
	1000	89	68	109	151	199	267	334	442	591	774	949	1177
12.5	1800	144	104	175	247	320	429	531	710	924	1241	1518	1879
	1500	120	87	145	206	267	358	443	592	770	1034	1265	1565
	1200	96	70	116	165	213	286	354	473	616	827	1012	1252
	1000	80	58	97	137	178	238	295	394	513	689	844	1044
14	1800	129	94	153	223	284	372	477	625	825	1099	1330	1654
	1500	107	78	127	186	236	310	397	521	688	916	1108	1379
	1200	86	62	102	149	189	248	318	417	550	733	886	1103
	1000	71	52	85	124	158	206	265	347	458	610	739	919
16	1800	113	83	136	198	253	332	429	552	751	954	1171	1471
	1500	94	70	113	165	210	277	358	460	626	795	976	1226
	1200	75	56	90	132	168	221	286	368	501	636	781	980
	1000	63	46	75	110	140	185	238	307	417	530	651	817
18	1800	100	74	121	176	235	294	382	496	662	852	1093	1288
	1500	83	62	101	147	196	245	318	413	551	710	911	1073
	1200	67	49	81	118	157	196	255	330	441	568	729	859
	1000	56	41	67	98	130	164	212	275	368	473	607	715
20	1800	90	66	–	154	–	262	–	446	–	776	–	1134
	1500	75	55	–	129	–	218	–	372	–	647	–	945
	1200	60	44	–	103	–	175	–	297	–	517	–	756
	1000	50	37	–	86	–	146	–	248	–	431	–	630
22.4	1800	80	–	–	137	–	244	–	397	–	683	–	1059
	1500	67	–	–	114	–	203	–	331	–	569	–	882
	1200	54	–	–	91	–	162	–	265	–	455	–	706
	1000	45	–	–	76	–	135	–	221	–	379	–	588
25	1800	72	–	–	122	–	–	–	–	–	–	–	–
	1500	60	–	–	102	–	–	–	–	–	–	–	–
	1200	48	–	–	81	–	–	–	–	–	–	–	–
	1000	40	–	–	68	–	–	–	–	–	–	–	–

Design of the gear units

Overview tables

Type H2 – Nominal output torques
Gear unit sizes 504 to 514

Technical data (continued)

Nominal output torques T_{2N} (kNm) Type H2

i_N	Gear unit sizes											Type
	504	505	506	507	508	509	510	511	512	513	514	
6.3	7	11.6	–	21.5	–	37	–	63.5	–	101.5	–	H2
7.1	7	11.6	–	21.5	–	37	–	63.5	–	101.5	–	
8	7	11.6	–	21.5	28.3	37	48.5	63.5	81	101.5	125	
9	7	11.6	16.2	21.5	28.3	37	48.5	63.5	81	101.5	125	
10	7	11.6	16.2	21.5	28.3	37	48.5	63.5	81	101.5	125	
11.2	7	11.6	16.2	21.5	28.3	37	48.5	63.5	81	101.5	125	
12.5	7	11.6	16.2	21.5	28.3	37	48.5	63.5	81	101.5	125	
14	7	11.6	16.2	21.5	28.3	37	48.5	63.5	81	101.5	125	
16	7	11.6	16.2	21.5	28.3	37	48.5	63.5	81	101.5	125	
18	7	11.6	16.2	21.5	28.3	37	48.5	63.5	81	101.5	125	
20	7	11.6	16.2	21.5	28.3	37	48.5	63.5	81	101.5	125	
22.4	–	11.6	16.2	21.5	28.3	37	48.5	63.5	81	101.5	125	
25	–	11.6	16.2	21.5	28.3	37	48.5	63.5	81	101.5	125	
28	–	11.6	16.2	21.5	28.3	37	48.5	63.5	81	101.5	125	
31.5	–	11.6	16.2	21.5	28.3	37	48.5	63.5	81	101.5	125	
35.5	–	11.6	16.2	21.5	28.3	37	48.5	63.5	81	101.5	125	
40	–	11.6	16.2	21.5	28.3	37	48.5	63.5	81	101.5	125	
45	–	11.6	16.2	21.5	28.3	37	48.5	63.5	81	101.5	125	
50	–	11.6	16.2	21.5	28.3	37	48.5	63.5	81	101.5	125	
56	–	11.6	16.2	21.5	28.3	37	48.5	63.5	81	101.5	125	
63	–	11.6	16.2	21.5	28.3	37	48.5	63.5	81	101.5	125	
71	–	11.6	16.2	21.5	28.3	37	48.5	63.5	81	101.5	125	
80	–	–	16.2	21.5	28.3	37	48.5	63.5	81	101.5	125	
90	–	–	16.2	21.5	28.3	37	48.5	63.5	81	101.5	125	
100	–	–	16.2	21.5	28.3	37	48.5	63.5	81	101.5	125	
112	–	–	–	21.5	28.3	37	48.5	63.5	81	101.5	125	
125	–	–	–	21.5	28.3	37	48.5	63.5	81	101.5	125	
140	–	–	–	21.5	28.3	37	48.5	63.5	81	101.5	125	
160	–	–	–	21.5	28.3	37	48.5	63.5	81	101.5	125	
180	–	–	–	21.5	28.3	37	48.5	63.5	81	101.5	125	
200	–	–	–	21.5	28.3	37	48.5	63.5	81	101.5	125	
224	–	–	–	21.5	28.3	37	48.5	63.5	81	101.5	125	
250	–	–	–	21.5	28.3	37	48.5	63.5	81	101.5	125	
280	–	–	–	21.5	28.3	37	48.5	63.5	81	101.5	125	
315	–	–	–	–	28.3	37	48.5	63.5	81	101.5	125	
355	–	–	–	–	28.3	–	48.5	–	81	–	125	
400	–	–	–	–	–	–	48.5	–	81	–	125	

Type H3, see page 3/17

Type H4, see page 3/23

Design of the gear units

Overview tables

Type H2 – Thermal capacities
 $n_1 = 1000$ rpm

Technical data (continued)

Thermal capacities P_G (kW) Type H2

i_N		Gear unit sizes										
		504	505	506	507	508	509	510	511	512	513	514
6.3	P_{GA}	56.7	70.8	–	97.5	–	122.5	–	140.0	–	155.5	–
	P_{GB}	120.9	148.9	–	232.3	–	293.5	–	472.3	–	559.5	–
	P_{GC}	122.6	248.6	–	296.8	–	537.9	–	634.4	–	1038.6	–
	P_{GD}	181.1	315.4	–	417.5	–	682.1	–	919.8	–	1361.9	–
7.1	P_{GA}	56.5	69.7	–	96.7	–	124.7	–	150.9	–	182.4	–
	P_{GB}	119.0	144.9	–	225.1	–	289.2	–	466.2	–	563.3	–
	P_{GC}	118.8	236.8	–	284.5	–	515.6	–	608.3	–	1005.1	–
	P_{GD}	175.9	300.7	–	398.4	–	655.6	–	883.4	–	1315.3	–
8	P_{GA}	55.2	69.3	–	91.9	110.4	128.4	137.1	158.4	162.2	201.2	189.7
	P_{GB}	115.2	141.9	–	209.5	255.5	286.0	316.3	457.5	511.5	561.3	612.9
	P_{GC}	113.7	226.0	–	258.3	315.3	497.8	430.1	587.1	799.2	964.5	1083.2
	P_{GD}	168.5	288.6	–	363.4	444.1	633.0	589.7	847.5	1096.2	1259.3	1426.2
9	P_{GA}	53.6	67.3	81.7	94.9	109.1	126.0	138.5	162.4	172.6	211.9	214.2
	P_{GB}	110.4	136.1	165.8	213.6	247.2	275.2	310.6	445.8	503.4	551.3	615.1
	P_{GC}	107.9	212.5	192.8	259.2	299.6	468.1	415.1	559.8	766.7	916.6	1050.1
	P_{GD}	160.4	272.2	268.6	364.8	423.1	597.2	567.8	806.8	1048.5	1194.2	1378.9
10	P_{GA}	50.3	65.2	80.1	89.7	103.3	123.1	141.8	163.5	178.2	218.0	231.0
	P_{GB}	102.8	130.4	160.6	198.0	229.2	263.0	308.4	429.5	493.6	534.3	609.6
	P_{GC}	99.0	200.8	183.9	235.7	272.8	436.1	400.8	525.8	733.6	863.3	1002.2
	P_{GD}	147.4	257.1	256.6	333.8	386.7	559.6	549.1	761.2	1003.2	1124.5	1315.9
11.2	P_{GA}	51.2	62.2	79.4	89.8	106.7	124.0	139.1	165.7	181.9	234.7	240.2
	P_{GB}	103.7	121.3	157.3	192.6	233.7	259.1	295.9	413.6	479.5	531.8	595.8
	P_{GC}	98.8	184.4	177.3	224.0	274.2	427.8	379.6	495.1	693.7	841.5	957.4
	P_{GD}	146.8	235.2	247.2	316.8	387.8	545.1	518.9	715.1	952.0	1095.3	1250.6
12.5	P_{GA}	48.7	59.1	76.9	90.2	100.4	115.4	135.4	172.7	181.5	233.1	244.5
	P_{GB}	96.7	114.4	150.3	186.7	216.6	236.9	282.7	406.2	461.2	513.1	576.4
	P_{GC}	92.1	169.5	167.7	217.0	249.0	382.1	355.5	477.2	651.6	789.6	895.6
	P_{GD}	136.5	217.7	234.3	304.4	355.0	487.9	488.0	684.2	893.8	1031.3	1172.5
14	P_{GA}	46.4	57.9	74.3	85.5	100.0	114.9	136.4	170.4	182.9	225.2	258.7
	P_{GB}	91.5	110.8	144.4	175.7	210.9	231.9	278.2	391.0	444.0	481.9	571.9
	P_{GC}	86.1	162.0	158.5	199.8	237.3	367.7	348.3	451.2	612.8	725.7	876.6
	P_{GD}	127.9	207.9	222.2	281.3	337.8	471.2	475.3	649.8	838.6	942.6	1143.2
16	P_{GA}	44.4	57.0	70.4	79.9	100.2	113.0	126.6	164.1	189.6	230.6	255.6
	P_{GB}	86.3	105.9	134.1	164.2	204.3	222.3	254.1	377.6	434.6	473.3	550.2
	P_{GC}	81.1	151.9	146.1	183.4	228.8	346.2	311.8	429.0	585.0	692.4	823.6
	P_{GD}	119.8	195.1	204.2	260.0	323.2	442.5	426.3	621.9	801.0	902.2	1076.7
18	P_{GA}	42.4	53.7	66.8	74.9	94.8	107.3	125.3	155.8	185.9	219.0	245.7
	P_{GB}	81.0	100.2	126.2	153.0	191.3	211.0	248.7	352.0	418.1	450.9	516.4
	P_{GC}	75.4	140.9	135.0	169.4	210.8	323.8	302.0	393.4	553.0	654.5	752.6
	P_{GD}	111.6	182.5	189.6	239.8	298.9	414.8	412.9	568.6	759.0	854.9	984.1
20	P_{GA}	40.9	–	65.4	–	88.6	–	123.1	–	179.1	–	250.4
	P_{GB}	77.7	–	121.9	–	178.7	–	238.0	–	404.2	–	504.8
	P_{GC}	71.4	–	129.1	–	193.8	–	285.0	–	527.7	–	721.5
	P_{GD}	105.4	–	181.2	–	276.4	–	388.8	–	726.6	–	938.2
22.4	P_{GA}	–	–	63.8	–	83.0	–	117.0	–	169.7	–	238.2
	P_{GB}	–	–	116.4	–	166.2	–	226.4	–	376.2	–	481.0
	P_{GC}	–	–	122.5	–	178.7	–	266.1	–	479.2	–	680.6
	P_{GD}	–	–	170.4	–	254.8	–	365.6	–	662.1	–	889.5
25	P_{GA}	–	–	60.1	–	–	–	–	–	–	–	–
	P_{GB}	–	–	110.2	–	–	–	–	–	–	–	–
	P_{GC}	–	–	114.2	–	–	–	–	–	–	–	–
	P_{GD}	–	–	160.1	–	–	–	–	–	–	–	–

For notes and legend for tables, see page 3/5

Technical data (continued)

Thermal capacities P_G (kW) Type H2

i_N		Gear unit sizes										
		504	505	506	507	508	509	510	511	512	513	514
6.3	P_{GA}	56.1	68.2	–	89.1	–	104.9	–	75.4	–	56.2	–
	P_{GB}	135.7	165.1	–	254.7	–	315.8	–	490.2	–	564.6	–
	P_{GC}	133.4	275.3	–	321.9	–	579.2	–	660.8	–	1089.1	–
	P_{GD}	205.2	357.0	–	466.5	–	755.4	–	1007.1	–	1478.0	–
7.1	P_{GA}	56.6	67.9	–	90.3	–	110.7	–	102.5	–	99.3	–
	P_{GB}	133.4	160.8	–	247.6	–	313.1	–	491.7	–	573.7	–
	P_{GC}	129.5	262.6	–	306.9	–	558.8	–	643.0	–	1061.8	–
	P_{GD}	198.9	341.0	–	446.0	–	728.7	–	973.4	–	1432.5	–
8	P_{GA}	55.5	68.6	–	87.5	102.7	118.2	119.6	121.4	101.7	131.8	96.4
	P_{GB}	129.3	158.0	–	231.1	279.6	312.6	340.2	488.1	533.3	573.6	624.1
	P_{GC}	123.9	249.6	–	280.2	340.5	540.4	458.7	622.9	844.7	1017.4	1151.9
	P_{GD}	190.5	326.2	–	408.1	496.9	705.7	651.4	936.8	1202.7	1374.0	1555.1
9	P_{GA}	54.3	67.0	80.2	91.5	103.4	119.1	125.2	133.6	126.0	161.6	137.1
	P_{GB}	124.6	151.9	184.2	236.3	272.2	302.3	336.2	480.0	533.4	574.3	631.0
	P_{GC}	117.9	236.4	209.6	281.2	323.1	509.9	444.1	595.4	819.3	981.7	1109.4
	P_{GD}	182.2	308.9	302.5	410.1	474.4	665.4	629.0	895.6	1159.4	1309.1	1505.2
10	P_{GA}	51.3	65.3	79.1	87.4	99.4	118.0	132.7	141.0	142.9	180.7	166.0
	P_{GB}	115.9	145.8	178.8	220.2	253.7	289.3	336.2	465.6	528.9	565.3	628.8
	P_{GC}	108.5	221.9	201.1	256.6	295.5	478.1	430.6	564.7	788.3	922.3	1063.3
	P_{GD}	167.6	291.5	290.1	375.9	433.7	625.9	610.5	845.8	1112.4	1239.1	1439.1
11.2	P_{GA}	52.5	63.1	79.4	89.1	104.0	121.4	132.6	150.4	154.1	212.9	192.5
	P_{GB}	117.2	136.1	175.4	214.8	259.4	285.7	325.4	453.1	517.9	570.9	624.6
	P_{GC}	108.0	203.9	193.0	244.9	297.4	469.6	408.6	533.6	748.4	910.1	1016.6
	P_{GD}	167.6	267.4	279.2	357.4	436.9	611.4	579.8	799.4	1058.5	1213.2	1374.5
12.5	P_{GA}	50.3	60.4	77.2	91.7	98.7	114.3	131.0	165.3	160.6	218.0	208.8
	P_{GB}	109.6	128.6	168.5	209.8	240.9	263.0	311.6	448.6	501.5	554.8	611.9
	P_{GC}	101.6	188.2	183.0	238.0	271.0	418.9	384.1	516.1	708.2	860.2	961.9
	P_{GD}	155.5	247.9	264.6	344.3	399.3	548.3	545.7	768.4	998.8	1146.4	1294.3
14	P_{GA}	48.1	59.6	75.1	87.4	100.0	114.9	134.4	166.2	169.0	216.5	239.9
	P_{GB}	103.8	124.8	161.7	197.3	234.5	258.4	307.3	434.4	486.5	526.0	616.2
	P_{GC}	94.6	179.8	173.5	219.6	258.5	403.6	378.7	493.1	661.3	790.9	951.8
	P_{GD}	145.8	236.8	251.7	318.6	381.0	530.8	532.5	731.1	939.8	1053.7	1269.2
16	P_{GA}	46.3	59.3	72.0	81.2	101.9	114.9	125.9	159.5	182.9	230.1	243.3
	P_{GB}	98.0	120.0	150.2	184.2	229.2	248.8	281.8	418.6	481.0	519.7	597.2
	P_{GC}	88.9	169.6	159.9	201.3	250.9	382.0	339.5	469.5	641.2	761.7	896.7
	P_{GD}	136.8	222.3	231.4	294.5	366.3	498.7	479.0	698.9	899.6	1009.8	1198.6
18	P_{GA}	44.4	55.6	68.6	76.4	97.1	108.8	126.2	152.9	182.7	217.8	239.6
	P_{GB}	92.1	113.1	142.0	171.8	214.9	235.8	277.2	391.0	464.0	495.1	564.0
	P_{GC}	83.3	157.0	148.4	185.6	231.6	356.3	328.9	426.2	608.7	720.7	824.3
	P_{GD}	127.4	207.8	215.1	272.0	338.8	468.1	464.4	641.5	855.6	958.1	1099.0
20	P_{GA}	43.1	–	67.6	–	90.1	–	125.6	–	175.6	–	251.4
	P_{GB}	88.4	–	137.8	–	200.5	–	266.2	–	448.0	–	555.3
	P_{GC}	78.8	–	141.8	–	211.8	–	311.9	–	578.7	–	791.3
	P_{GD}	121.1	–	206.0	–	312.8	–	438.2	–	818.7	–	1054.7
22.4	P_{GA}	–	–	66.8	–	84.8	–	118.9	–	168.0	–	238.3
	P_{GB}	–	–	131.5	–	186.8	–	252.7	–	418.7	–	529.4
	P_{GC}	–	–	134.8	–	195.5	–	291.5	–	527.8	–	747.9
	P_{GD}	–	–	194.2	–	289.2	–	412.1	–	747.3	–	998.5
25	P_{GA}	–	–	62.6	–	–	–	–	–	–	–	–
	P_{GB}	–	–	124.1	–	–	–	–	–	–	–	–
	P_{GC}	–	–	125.2	–	–	–	–	–	–	–	–
	P_{GD}	–	–	182.0	–	–	–	–	–	–	–	–

Design of the gear units

Overview tables

Type H2 – Thermal capacities
 $n_1 = 1500 \text{ rpm}$

Technical data (continued)

Thermal capacities P_G (kW) Type H2

i_N		Gear unit sizes										
		504	505	506	507	508	509	510	511	512	513	514
6.3	P_{GA}	52.7	59.9	–	67.7	–	59.2	–	*	–	*	–
	P_{GB}	154.6	184.4	–	278.5	–	334.4	–	504.4	–	530.0	–
	P_{GC}	146.4	306.4	–	347.4	–	621.4	–	687.2	–	1135.8	–
	P_{GD}	238.0	411.6	–	530.2	–	842.9	–	1116.8	–	1607.7	–
7.1	P_{GA}	54.3	61.4	–	73.5	–	74.7	–	*	–	*	–
	P_{GB}	152.9	180.9	–	272.9	–	334.9	–	510.4	–	562.3	–
	P_{GC}	142.5	294.1	–	334.5	–	603.7	–	670.3	–	1116.8	–
	P_{GD}	231.7	393.8	–	509.0	–	816.7	–	1083.4	–	1573.9	–
8	P_{GA}	54.1	64.0	–	75.2	82.4	92.8	75.8	33.7	*	*	*
	P_{GB}	148.7	179.2	–	257.7	308.2	339.9	362.1	510.8	553.1	579.1	598.4
	P_{GC}	136.9	282.4	–	307.6	366.2	586.0	482.4	651.5	901.1	1087.8	1190.6
	P_{GD}	222.5	379.2	–	466.9	564.1	794.2	727.8	1043.5	1342.1	1519.7	1698.1
9	P_{GA}	53.5	63.6	73.6	81.2	87.3	99.2	90.3	58.9	27.8	50.8	*
	P_{GB}	143.2	172.7	207.5	263.9	301.7	332.4	362.5	506.0	557.7	584.2	626.7
	P_{GC}	130.3	266.7	230.7	308.2	353.3	558.5	470.5	625.1	876.4	1050.2	1179.8
	P_{GD}	212.4	359.0	349.2	469.6	541.6	755.6	708.2	999.7	1296.1	1454.4	1651.6
10	P_{GA}	51.1	62.8	74.3	79.4	87.6	103.1	108.2	84.1	58.7	89.9	39.0
	P_{GB}	133.8	166.4	202.1	247.0	282.2	321.3	367.6	498.8	555.5	580.7	640.7
	P_{GC}	120.5	251.0	221.4	281.8	323.1	524.7	463.7	599.4	837.0	998.3	1144.6
	P_{GD}	195.6	339.3	334.9	431.1	496.5	710.4	692.4	952.9	1245.6	1375.7	1594.1
11.2	P_{GA}	52.5	62.5	76.1	84.5	94.0	111.4	113.8	111.1	84.0	155.2	87.2
	P_{GB}	135.2	156.5	199.2	243.6	290.7	319.6	357.9	493.1	550.1	602.9	643.8
	P_{GC}	119.9	231.7	213.5	271.6	324.5	516.9	443.6	575.8	802.3	987.8	1092.4
	P_{GD}	195.5	312.2	323.0	412.2	500.4	695.6	658.5	904.4	1188.3	1359.4	1523.7
12.5	P_{GA}	51.3	60.3	74.9	90.6	91.3	107.4	116.9	142.3	106.9	176.2	123.5
	P_{GB}	127.2	148.1	191.8	239.9	270.8	295.0	346.2	498.6	540.3	595.1	634.8
	P_{GC}	113.2	214.6	201.6	265.7	297.9	463.5	417.1	568.0	766.1	941.9	1033.3
	P_{GD}	182.9	288.8	307.3	399.5	457.9	628.3	621.5	879.2	1128.0	1291.2	1440.4
14	P_{GA}	49.3	60.3	73.6	87.1	95.9	110.0	124.9	148.9	131.4	186.6	184.5
	P_{GB}	120.7	144.2	184.6	226.1	266.2	291.6	344.4	484.8	531.8	569.8	655.4
	P_{GC}	105.8	203.7	192.4	244.3	285.5	451.6	415.0	541.5	727.1	873.0	1032.2
	P_{GD}	171.3	276.3	291.7	369.9	439.6	608.3	609.6	838.5	1064.9	1189.0	1421.8
16	P_{GA}	48.0	61.8	72.2	80.4	101.7	113.7	119.3	142.2	161.1	216.5	203.5
	P_{GB}	114.4	139.3	173.1	210.3	261.7	283.7	316.8	467.4	535.0	574.3	643.6
	P_{GC}	99.8	193.4	177.8	223.2	280.3	427.4	372.8	511.9	705.6	847.5	980.5
	P_{GD}	161.0	261.4	268.8	341.0	424.4	576.5	549.5	801.3	1030.8	1150.5	1348.2
18	P_{GA}	46.7	57.3	69.3	76.0	97.5	107.4	122.2	140.2	166.9	203.5	212.0
	P_{GB}	107.9	131.0	163.0	197.0	246.4	268.6	313.1	439.1	520.4	547.2	614.9
	P_{GC}	93.7	179.6	165.4	207.0	258.1	397.9	363.7	468.8	672.1	801.4	907.7
	P_{GD}	149.9	243.3	250.8	315.2	392.8	538.9	534.0	735.4	980.3	1090.9	1242.5
20	P_{GA}	45.4	–	69.1	–	90.2	–	125.4	–	159.9	–	240.4
	P_{GB}	103.6	–	159.2	–	229.9	–	304.0	–	501.7	–	616.0
	P_{GC}	88.8	–	158.8	–	236.0	–	347.1	–	642.0	–	882.5
	P_{GD}	142.4	–	240.6	–	362.2	–	507.2	–	936.6	–	1199.7
22.4	P_{GA}	–	–	70.0	–	85.0	–	118.5	–	156.2	–	226.0
	P_{GB}	–	–	153.0	–	214.4	–	288.0	–	469.8	–	586.4
	P_{GC}	–	–	152.0	–	218.0	–	323.7	–	586.9	–	828.8
	P_{GD}	–	–	227.6	–	334.8	–	475.5	–	858.4	–	1135.7
25	P_{GA}	–	–	65.0	–	–	–	–	–	–	–	–
	P_{GB}	–	–	144.3	–	–	–	–	–	–	–	–
	P_{GC}	–	–	140.6	–	–	–	–	–	–	–	–
	P_{GD}	–	–	213.0	–	–	–	–	–	–	–	–

For notes and legend for tables, see page 3/5

Technical data (continued)

Thermal capacities P_G (kW) Type H2

i_N		Gear unit sizes										
		504	505	506	507	508	509	510	511	512	513	514
6.3	P_{GA}	45.7	45.4	–	34.0	–	*	–	*	–	*	–
	P_{GB}	170.3	199.5	–	293.3	–	345.7	–	482.8	–	433.4	–
	P_{GC}	156.5	332.9	–	362.8	–	654.1	–	685.5	–	1132.2	–
	P_{GD}	267.2	459.6	–	581.1	–	918.7	–	1188.6	–	1680.5	–
7.1	P_{GA}	49.3	50.0	–	44.9	–	28.1	–	*	–	*	–
	P_{GB}	169.6	196.5	–	289.9	–	349.2	–	503.5	–	499.8	–
	P_{GC}	153.3	320.8	–	351.2	–	638.5	–	681.9	–	1131.5	–
	P_{GD}	261.0	441.3	–	559.2	–	892.2	–	1164.0	–	1657.2	–
8	P_{GA}	50.2	55.5	–	53.9	49.9	51.9	22.6	*	*	*	*
	P_{GB}	165.1	196.1	–	275.8	325.4	356.6	375.2	514.6	536.3	542.2	510.5
	P_{GC}	147.0	308.3	–	325.6	384.7	623.7	502.9	668.9	921.0	1115.3	1186.6
	P_{GD}	250.4	425.0	–	515.6	617.3	870.0	792.4	1129.0	1441.9	1616.5	1769.5
9	P_{GA}	50.5	56.7	61.4	63.7	60.6	66.4	44.1	*	*	*	*
	P_{GB}	159.9	189.9	225.4	284.4	320.4	350.7	379.5	516.8	554.8	566.7	570.5
	P_{GC}	141.0	291.2	245.4	328.5	371.1	594.5	493.7	649.1	903.2	1090.6	1186.0
	P_{GD}	239.6	402.7	389.1	520.7	594.6	827.5	771.3	1087.9	1401.8	1558.3	1745.3
10	P_{GA}	49.0	57.4	64.9	65.8	67.7	78.0	68.8	*	*	*	*
	P_{GB}	149.4	183.7	221.3	267.9	303.8	342.8	386.1	513.7	565.0	577.8	610.1
	P_{GC}	130.1	276.7	236.3	301.5	341.9	562.0	484.3	618.2	874.9	1042.7	1168.5
	P_{GD}	221.2	383.0	374.5	478.7	548.3	782.6	755.5	1036.3	1354.7	1486.6	1701.4
11.2	P_{GA}	51.1	59.5	69.0	75.4	77.6	93.7	82.5	45.4	*	75.6	*
	P_{GB}	151.7	174.1	219.3	265.9	313.2	345.7	378.3	512.3	566.7	617.5	631.6
	P_{GC}	130.0	256.5	229.0	291.6	345.9	557.8	464.4	594.9	850.3	1056.3	1142.9
	P_{GD}	220.9	353.3	362.3	460.1	552.7	770.3	720.8	986.1	1302.0	1478.5	1636.7
12.5	P_{GA}	50.8	58.1	69.3	86.3	78.4	94.2	93.1	102.8	29.4	109.4	*
	P_{GB}	142.9	165.0	211.8	265.3	294.5	320.4	368.8	529.6	558.9	612.4	638.2
	P_{GC}	123.4	236.4	218.0	288.8	317.8	503.0	442.4	598.3	807.7	1000.0	1091.8
	P_{GD}	207.3	327.7	344.7	447.7	508.8	695.5	681.9	964.5	1234.3	1405.3	1556.1
14	P_{GA}	49.2	59.2	69.1	84.2	87.5	100.5	107.6	120.1	68.6	135.3	111.1
	P_{GB}	135.8	161.2	204.6	250.6	291.9	318.9	371.6	521.3	555.7	592.9	674.7
	P_{GC}	115.3	226.5	207.5	266.8	307.2	489.9	441.0	577.7	767.0	930.0	1094.3
	P_{GD}	194.5	313.2	327.3	415.3	489.6	677.2	672.7	925.8	1169.7	1300.5	1549.2
16	P_{GA}	48.7	62.9	70.1	76.7	98.2	108.8	107.2	114.0	124.2	189.3	139.8
	P_{GB}	129.4	157.1	192.4	233.2	289.6	312.8	344.9	501.6	570.6	609.9	666.5
	P_{GC}	109.5	215.8	193.9	242.8	303.9	468.5	400.4	545.6	760.5	915.5	1048.5
	P_{GD}	183.2	296.5	303.6	383.1	475.7	642.7	609.7	884.7	1139.7	1271.7	1468.4
18	P_{GA}	48.2	57.5	67.9	73.2	95.4	102.1	113.0	117.5	139.6	176.1	164.0
	P_{GB}	122.4	147.0	182.4	218.4	273.5	295.6	342.4	473.4	559.8	579.7	642.3
	P_{GC}	103.1	198.4	180.2	225.0	280.6	435.3	391.0	501.0	729.5	861.7	966.6
	P_{GD}	171.4	276.0	283.1	354.5	441.2	603.2	594.0	814.7	1087.6	1201.3	1363.8
20	P_{GA}	47.0	–	68.6	–	87.0	–	120.6	–	132.2	–	215.3
	P_{GB}	117.5	–	177.7	–	253.9	–	333.9	–	539.6	–	658.2
	P_{GC}	97.6	–	173.1	–	256.0	–	374.6	–	689.3	–	952.8
	P_{GD}	162.8	–	272.4	–	406.4	–	567.1	–	1039.1	–	1323.7
22.4	P_{GA}	–	–	71.7	–	82.6	–	113.6	–	134.8	–	200.2
	P_{GB}	–	–	173.1	–	237.0	–	317.1	–	509.6	–	625.8
	P_{GC}	–	–	167.5	–	236.1	–	348.0	–	634.2	–	894.6
	P_{GD}	–	–	259.4	–	375.7	–	531.1	–	954.3	–	1253.7
25	P_{GA}	–	–	65.9	–	–	–	–	–	–	–	–
	P_{GB}	–	–	162.3	–	–	–	–	–	–	–	–
	P_{GC}	–	–	153.9	–	–	–	–	–	–	–	–
	P_{GD}	–	–	241.8	–	–	–	–	–	–	–	–

Design of the gear units

Overview tables

Type H3
Nominal power ratings, gear unit sizes 505 to 514

Technical data

Nominal power ratings P_{2N} (kW) for H3

i_N	n_1	n_2	Gear unit sizes										
			504	505	506	507	508	509	510	511	512	513	514
20	1800	90	–	107	–	197	–	338	–	600	–	959	–
	1500	75	–	89	–	164	–	282	–	500	–	799	–
	1200	60	–	71	–	131	–	225	–	400	–	639	–
	1000	50	–	59	–	109	–	188	–	333	–	533	–
22.4	1800	80	–	95	–	176	–	298	–	521	–	852	–
	1500	67	–	79	–	147	–	248	–	434	–	710	–
	1200	54	–	63	–	117	–	199	–	347	–	568	–
	1000	45	–	53	–	98	–	166	–	289	–	474	–
25	1800	72	–	83	–	156	204	268	351	465	619	746	929
	1500	60	–	69	–	130	170	223	293	388	516	622	774
	1200	48	–	56	–	104	136	178	234	310	413	498	619
	1000	40	–	46	–	87	114	149	195	258	344	415	516
28	1800	64	–	77	108	145	183	234	310	416	538	672	826
	1500	54	–	64	90	121	152	195	258	346	448	560	688
	1200	43	–	51	72	97	122	156	207	277	358	448	550
	1000	36	–	43	60	81	101	130	172	231	299	373	459
31.5	1800	57	–	67	96	129	162	210	278	371	480	588	723
	1500	48	–	56	80	107	135	175	232	309	400	490	603
	1200	38	–	45	64	86	108	140	185	248	320	392	482
	1000	32	–	37	53	71	90	117	155	206	267	327	402
35.5	1800	51	–	63	84	116	150	192	244	333	429	537	651
	1500	42	–	52	70	97	125	160	203	277	358	448	543
	1200	34	–	42	56	78	100	128	162	222	286	358	434
	1000	28	–	35	47	65	84	107	135	185	239	298	362
40	1800	45	–	55	78	103	133	172	219	297	383	470	570
	1500	38	–	46	65	86	111	144	182	248	319	392	475
	1200	30	–	37	52	69	89	115	146	198	256	314	380
	1000	25	–	31	43	57	74	96	121	165	213	261	317
45	1800	40	–	50	68	90	121	152	199	257	343	417	520
	1500	33	–	42	57	75	101	126	166	214	286	348	434
	1200	27	–	33	45	60	81	101	133	172	229	278	347
	1000	22	–	28	38	50	67	84	111	143	191	232	289
50	1800	36	–	44	64	80	107	136	179	230	307	366	456
	1500	30	–	36	53	66	89	114	149	191	256	305	380
	1200	24	–	29	42	53	71	91	119	153	205	244	304
	1000	20	–	24	35	44	59	76	99	128	170	203	253
56	1800	32	–	38	56	71	93	119	158	204	266	328	404
	1500	27	–	32	46	59	78	99	131	170	221	274	337
	1200	21	–	26	37	47	62	80	105	136	177	219	270
	1000	18	–	21	31	39	52	66	88	113	148	182	225
63	1800	29	–	34	50	63	83	105	142	189	237	300	354
	1500	24	–	29	42	53	69	87	118	157	198	250	295
	1200	19	–	23	34	42	55	70	94	126	158	200	236
	1000	16	–	19	28	35	46	58	79	105	132	167	197
71	1800	25	–	30	44	56	74	94	124	169	210	263	318
	1500	21	–	25	37	47	61	79	103	140	175	219	265
	1200	17	–	20	29	37	49	63	83	112	140	175	212
	1000	14	–	17	25	31	41	52	69	94	117	146	177
80	1800	23	–	–	39	–	66	–	109	–	195	–	291
	1500	19	–	–	32	–	55	–	91	–	162	–	242
	1200	15	–	–	26	–	44	–	73	–	130	–	194
	1000	13	–	–	21	–	37	–	61	–	108	–	162
90	1800	20	–	–	35	–	58	–	98	–	174	–	255
	1500	17	–	–	29	–	49	–	82	–	145	–	212
	1200	13	–	–	23	–	39	–	65	–	116	–	170
	1000	11	–	–	19	–	32	–	54	–	97	–	142
100	1800	18	–	–	31	–	–	–	–	–	–	–	–
	1500	15	–	–	25	–	–	–	–	–	–	–	–
	1200	12	–	–	20	–	–	–	–	–	–	–	–
	1000	10	–	–	17	–	–	–	–	–	–	–	–

Design of the gear units

Overview tables

Type H3 – Nominal output torques Gear unit sizes 505 to 514

Technical data (continued)

Nominal output torques T_{2N} (kNm) Type H3

i_N	Gear unit sizes											Type
	504	505	506	507	508	509	510	511	512	513	514	
6.3	7	11.6	–	21.5	–	37	–	63.5	–	101.5	–	H2
7.1	7	11.6	–	21.5	–	37	–	63.5	–	101.5	–	
8	7	11.6	–	21.5	28.3	37	48.5	63.5	81	101.5	125	
9	7	11.6	16.2	21.5	28.3	37	48.5	63.5	81	101.5	125	
10	7	11.6	16.2	21.5	28.3	37	48.5	63.5	81	101.5	125	
11.2	7	11.6	16.2	21.5	28.3	37	48.5	63.5	81	101.5	125	
12.5	7	11.6	16.2	21.5	28.3	37	48.5	63.5	81	101.5	125	
14	7	11.6	16.2	21.5	28.3	37	48.5	63.5	81	101.5	125	
16	7	11.6	16.2	21.5	28.3	37	48.5	63.5	81	101.5	125	
18	7	11.6	16.2	21.5	28.3	37	48.5	63.5	81	101.5	125	
20	7	11.6	16.2	21.5	28.3	37	48.5	63.5	81	101.5	125	
22.4	–	11.6	16.2	21.5	28.3	37	48.5	63.5	81	101.5	125	
25	–	11.6	16.2	21.5	28.3	37	48.5	63.5	81	101.5	125	
28	–	11.6	16.2	21.5	28.3	37	48.5	63.5	81	101.5	125	
31.5	–	11.6	16.2	21.5	28.3	37	48.5	63.5	81	101.5	125	
35.5	–	11.6	16.2	21.5	28.3	37	48.5	63.5	81	101.5	125	
40	–	11.6	16.2	21.5	28.3	37	48.5	63.5	81	101.5	125	
45	–	11.6	16.2	21.5	28.3	37	48.5	63.5	81	101.5	125	
50	–	11.6	16.2	21.5	28.3	37	48.5	63.5	81	101.5	125	
56	–	11.6	16.2	21.5	28.3	37	48.5	63.5	81	101.5	125	
63	–	11.6	16.2	21.5	28.3	37	48.5	63.5	81	101.5	125	
71	–	11.6	16.2	21.5	28.3	37	48.5	63.5	81	101.5	125	
80	–	–	16.2	21.5	28.3	37	48.5	63.5	81	101.5	125	
90	–	–	16.2	21.5	28.3	37	48.5	63.5	81	101.5	125	
100	–	–	16.2	21.5	28.3	37	48.5	63.5	81	101.5	125	
112	–	–	–	21.5	28.3	37	48.5	63.5	81	101.5	125	
125	–	–	–	21.5	28.3	37	48.5	63.5	81	101.5	125	
140	–	–	–	21.5	28.3	37	48.5	63.5	81	101.5	125	
160	–	–	–	21.5	28.3	37	48.5	63.5	81	101.5	125	
180	–	–	–	21.5	28.3	37	48.5	63.5	81	101.5	125	
200	–	–	–	21.5	28.3	37	48.5	63.5	81	101.5	125	
224	–	–	–	21.5	28.3	37	48.5	63.5	81	101.5	125	
250	–	–	–	21.5	28.3	37	48.5	63.5	81	101.5	125	
280	–	–	–	21.5	28.3	37	48.5	63.5	81	101.5	125	
315	–	–	–	–	28.3	37	48.5	63.5	81	101.5	125	
355	–	–	–	–	28.3	–	48.5	–	81	–	125	
400	–	–	–	–	–	–	48.5	–	81	–	125	

Type H2, see page 3/11

Type H4, see page 3/23

Design of the gear units

Overview tables

Type H3 – Thermal capacities
 $n_1 = 1000$ rpm

Technical data (continued)

Thermal capacities P_G (kW) Type H3

i_N		Gear unit sizes									
		505	506	507	508	509	510	511	512	513	514
20	P_{GA}	46.3	–	74.2	–	101.1	–	141.8	–	189.3	–
	P_{GB}	72.9	–	121.5	–	165.7	–	241.3	–	278.6	–
	P_{GC}	123.3	–	166.0	–	304.7	–	357.9	–	569.6	–
	P_{GD}	145.8	–	208.5	–	359.4	–	445.8	–	641.7	–
22.4	P_{GA}	44.2	–	71.1	–	94.7	–	137.5	–	184.1	–
	P_{GB}	69.6	–	116.8	–	154.8	–	234.0	–	269.8	–
	P_{GC}	117.8	–	159.3	–	283.9	–	345.5	–	551.4	–
	P_{GD}	139.5	–	200.1	–	335.8	–	430.4	–	618.9	–
25	P_{GA}	43.4	–	68.2	81.1	93.7	109.7	133.2	153.5	175.8	204.8
	P_{GB}	68.2	–	111.7	131.3	152.9	176.8	225.8	257.0	256.9	296.3
	P_{GC}	115.3	–	152.4	174.2	279.5	249.4	333.4	436.3	521.5	586.0
	P_{GD}	136.7	–	191.7	219.4	331.7	310.0	416.3	525.0	586.8	662.8
28	P_{GA}	42.1	51.7	67.3	78.0	90.7	102.6	128.4	149.1	179.1	198.3
	P_{GB}	65.7	79.9	109.1	126.0	146.3	165.3	213.8	248.9	258.0	286.8
	P_{GC}	107.3	98.8	144.8	166.8	258.4	233.2	305.9	419.9	499.2	567.7
	P_{GD}	127.9	124.4	182.8	210.1	306.5	288.9	382.0	508.1	565.7	638.7
31.5	P_{GA}	41.1	49.5	64.3	74.7	98.4	101.3	124.4	144.5	170.0	188.7
	P_{GB}	64.2	76.4	104.5	120.5	144.0	163.2	206.7	240.6	245.0	272.7
	P_{GC}	104.5	94.4	138.8	159.7	254.3	230.3	294.8	406.8	474.6	537.7
	P_{GD}	124.7	119.1	174.8	201.0	301.9	284.9	368.8	490.5	535.0	605.6
35.5	P_{GA}	38.9	48.4	63.5	73.6	84.8	98.1	123.1	138.6	166.7	192.0
	P_{GB}	60.4	74.8	102.0	117.8	135.3	156.1	201.9	227.7	237.9	273.1
	P_{GC}	97.2	92.4	131.9	152.7	234.7	212.4	277.5	370.0	445.7	516.7
	P_{GD}	115.9	116.5	166.5	192.5	277.9	264.6	349.0	448.5	506.2	584.5
40	P_{GA}	38.1	46.8	60.8	70.4	83.6	96.7	118.9	134.1	158.5	182.4
	P_{GB}	59.0	72.0	97.5	112.4	133.5	153.5	195.4	220.0	225.8	258.9
	P_{GC}	94.8	86.5	126.2	145.9	231.0	210.1	268.4	357.7	421.8	488.3
	P_{GD}	113.1	109.8	158.9	184.3	274.4	261.2	337.0	432.3	478.0	552.0
45	P_{GA}	34.9	45.7	57.4	69.4	76.7	91.6	114.7	132.1	153.9	178.8
	P_{GB}	53.5	70.3	90.9	110.0	120.6	144.2	184.8	214.5	216.1	251.7
	P_{GC}	83.7	84.5	116.0	138.2	204.4	194.0	249.8	336.7	393.6	460.1
	P_{GD}	100.2	107.2	146.0	175.4	242.6	241.6	313.1	407.9	445.2	520.4
50	P_{GA}	34.2	43.3	55.0	66.3	75.8	90.3	110.6	128.2	146.3	169.6
	P_{GB}	52.4	66.1	87.1	105.3	118.9	142.3	178.6	207.5	205.0	238.5
	P_{GC}	81.8	78.9	110.9	132.3	201.4	191.0	241.7	324.1	372.5	435.0
	P_{GD}	97.9	99.8	139.7	167.8	239.8	238.0	303.1	394.5	421.1	493.3
56	P_{GA}	33.4	42.4	52.8	62.5	74.2	82.7	106.4	123.1	143.4	164.1
	P_{GB}	51.0	64.6	82.9	97.9	115.4	128.5	170.5	196.3	200.0	227.8
	P_{GC}	79.0	77.2	104.6	121.4	192.4	169.3	228.7	301.6	357.5	404.5
	P_{GD}	94.6	97.7	132.0	153.6	229.1	211.4	286.2	366.4	404.3	458.4
63	P_{GA}	31.2	38.8	50.6	59.8	70.4	81.7	102.4	118.9	141.7	155.8
	P_{GB}	47.0	58.5	78.5	93.8	107.8	127.0	161.7	189.3	195.3	216.1
	P_{GC}	70.8	68.6	96.7	116.3	174.7	167.3	210.2	291.5	336.5	383.2
	P_{GD}	84.7	86.8	122.0	147.3	208.2	208.1	263.8	353.8	383.0	435.0
71	P_{GA}	30.5	38.0	48.5	57.5	69.4	80.0	99.3	114.4	134.4	152.8
	P_{GB}	45.9	57.3	75.4	89.5	106.4	122.9	156.2	180.4	184.7	210.9
	P_{GC}	69.3	67.0	92.6	109.9	172.4	160.2	203.6	275.2	318.5	367.5
	P_{GD}	82.8	84.9	117.0	139.1	205.3	199.1	255.2	333.5	361.6	417.3
80	P_{GA}	–	37.2	–	55.1	–	75.6	–	109.8	–	150.5
	P_{GB}	–	55.6	–	84.6	–	114.8	–	170.9	–	205.4
	P_{GC}	–	65.1	–	101.7	–	146.3	–	251.7	–	346.5
	P_{GD}	–	81.9	–	128.6	–	182.1	–	306.9	–	393.4
90	P_{GA}	–	34.6	–	52.8	–	74.5	–	106.3	–	142.4
	P_{GB}	–	51.2	–	81.1	–	113.4	–	165.6	–	194.6
	P_{GC}	–	58.7	–	97.3	–	144.6	–	244.5	–	328.4
	P_{GD}	–	73.9	–	123.2	–	179.6	–	297.0	–	372.5
100	P_{GA}	–	33.9	–	–	–	–	–	–	–	–
	P_{GB}	–	50.2	–	–	–	–	–	–	–	–
	P_{GC}	–	57.3	–	–	–	–	–	–	–	–
	P_{GD}	–	72.5	–	–	–	–	–	–	–	–

For notes and legend for tables, see page 3/5

Design of the gear units

Overview tables

Type H3 – Thermal capacities
 $n_1 = 1200 \text{ rpm}$

Technical data (continued)

Thermal capacities P_G (kW) Type H3

i_N		Gear unit sizes									
		505	506	507	508	509	510	511	512	513	514
20	P_{GA}	48.1	–	76.4	–	102.7	–	141.1	–	185.7	–
	P_{GB}	81.2	–	135.1	–	182.7	–	264.3	–	295.9	–
	P_{GC}	136.8	–	183.4	–	335.9	–	391.6	–	624.2	–
	P_{GD}	165.6	–	235.5	–	404.6	–	499.8	–	712.6	–
22.4	P_{GA}	46.1	–	73.6	–	96.4	–	137.6	–	181.4	–
	P_{GB}	77.9	–	130.2	–	171.1	–	255.9	–	287.5	–
	P_{GC}	131.4	–	176.2	–	313.4	–	379.4	–	603.1	–
	P_{GD}	158.6	–	225.9	–	378.0	–	482.2	–	687.8	–
25	P_{GA}	45.1	–	70.6	83.9	95.2	111.9	133.3	153.7	173.3	202.2
	P_{GB}	76.0	–	124.6	146.2	168.7	195.5	247.7	281.0	273.6	314.9
	P_{GC}	128.3	–	168.2	192.1	308.3	273.3	366.3	480.8	570.8	644.7
	P_{GD}	154.9	–	216.4	248.0	372.4	348.7	466.7	590.0	654.8	734.6
28	P_{GA}	43.8	54.0	69.8	80.5	93.4	105.0	130.4	149.6	180.7	196.9
	P_{GB}	73.3	89.2	122.0	140.3	162.2	182.7	235.6	272.4	277.4	305.9
	P_{GC}	119.3	108.9	160.7	183.9	285.8	256.0	335.0	463.2	551.8	622.6
	P_{GD}	144.6	141.0	206.7	237.5	344.0	325.1	428.9	570.2	630.1	709.3
31.5	P_{GA}	42.9	51.7	67.0	77.3	92.2	103.7	126.5	144.7	172.2	188.4
	P_{GB}	71.8	85.2	116.7	134.3	160.1	180.2	227.7	263.4	263.6	291.0
	P_{GC}	116.9	104.1	153.4	176.6	280.9	252.3	324.7	447.3	521.3	591.3
	P_{GD}	141.8	134.7	198.2	227.1	340.2	320.5	414.7	549.1	598.4	674.8
35.5	P_{GA}	40.8	50.4	66.3	76.6	87.8	101.0	126.2	141.2	171.0	194.1
	P_{GB}	67.7	83.4	114.0	131.5	150.7	173.0	223.2	251.0	258.2	294.2
	P_{GC}	108.7	101.9	145.8	168.4	260.3	233.6	306.5	409.7	493.3	567.5
	P_{GD}	132.0	181.4	188.5	217.5	313.2	297.6	392.8	505.0	563.8	649.3
40	P_{GA}	39.9	49.0	63.5	73.4	86.6	99.8	121.9	136.9	162.4	185.3
	P_{GB}	66.1	80.5	109.2	125.9	148.5	170.3	215.9	242.7	244.9	279.3
	P_{GC}	105.9	95.6	139.7	161.0	256.0	231.3	296.5	394.5	468.4	537.9
	P_{GD}	128.7	124.2	180.4	208.1	309.5	293.8	379.9	487.4	534.8	614.4
45	P_{GA}	36.8	47.9	60.4	72.6	80.1	94.9	118.8	136.3	159.0	183.4
	P_{GB}	60.1	78.5	102.1	122.9	135.0	160.2	205.6	237.3	235.6	273.2
	P_{GC}	93.6	93.4	128.3	153.3	227.1	213.1	276.1	372.1	434.3	507.1
	P_{GD}	113.8	121.3	165.6	198.5	274.7	272.4	353.5	459.5	500.2	582.3
50	P_{GA}	36.0	45.5	57.8	69.5	79.1	93.8	114.9	131.6	151.3	174.4
	P_{GB}	58.7	74.0	97.7	117.8	132.8	158.2	198.5	229.3	223.9	258.7
	P_{GC}	91.2	87.1	122.6	146.1	224.4	211.0	266.9	359.6	413.2	480.6
	P_{GD}	111.1	113.3	158.4	190.1	270.8	286.3	341.5	444.2	472.8	549.8
56	P_{GA}	35.4	44.4	55.8	65.9	77.9	86.5	111.1	127.6	149.8	170.3
	P_{GB}	57.3	72.4	93.4	110.0	129.2	143.3	189.9	218.1	219.3	248.7
	P_{GC}	88.3	85.3	115.9	134.3	214.8	187.1	252.8	333.4	395.3	449.0
	P_{GD}	107.5	110.6	150.0	174.7	259.2	238.4	323.3	413.7	453.7	514.4
63	P_{GA}	33.2	40.8	53.7	63.1	74.4	85.5	107.9	123.5	148.9	161.8
	P_{GB}	52.9	65.6	88.4	105.4	121.2	141.5	180.4	210.5	214.7	235.5
	P_{GC}	79.2	75.6	107.4	128.8	195.5	185.1	233.1	323.1	375.0	424.9
	P_{GD}	96.6	98.2	138.8	167.0	235.5	234.9	298.7	398.6	430.8	486.4
71	P_{GA}	32.5	40.1	51.4	60.8	73.5	84.1	104.3	119.5	141.7	159.6
	P_{GB}	51.8	64.2	84.9	100.6	119.5	137.9	175.1	201.5	203.8	230.9
	P_{GC}	77.4	74.1	102.7	121.6	192.5	176.9	225.6	305.5	355.1	406.6
	P_{GD}	94.3	96.2	132.9	158.0	232.6	225.2	288.8	377.7	407.0	467.5
80	P_{GA}	–	39.3	–	58.4	–	80.2	–	115.5	–	158.5
	P_{GB}	–	62.6	–	95.3	–	128.7	–	191.0	–	226.4
	P_{GC}	–	71.7	–	112.2	–	162.2	–	281.3	–	385.9
	P_{GD}	–	93.1	–	146.3	–	206.1	–	348.2	–	443.1
90	P_{GA}	–	36.8	–	56.0	–	79.0	–	112.0	–	150.1
	P_{GB}	–	57.7	–	91.4	–	127.2	–	185.0	–	214.4
	P_{GC}	–	64.8	–	107.9	–	160.1	–	270.8	–	364.7
	P_{GD}	–	84.2	–	140.2	–	203.5	–	337.1	–	420.2
100	P_{GA}	–	36.0	–	–	–	–	–	–	–	–
	P_{GB}	–	56.4	–	–	–	–	–	–	–	–
	P_{GC}	–	63.4	–	–	–	–	–	–	–	–
	P_{GD}	–	82.4	–	–	–	–	–	–	–	–

For notes and legend for tables, see page 3/5

Design of the gear units

Overview tables

Type H3 – Thermal capacities
 $n_1 = 1500 \text{ rpm}$

Technical data (continued)

Thermal capacities P_G (kW) Type H3

i_N	Gear unit sizes	Gear unit sizes									
		505	506	507	508	509	510	511	512	513	514
20	P_{GA}	49.7	–	77.8	–	101.5	–	132.6	–	168.2	–
	P_{GB}	92.8	–	154.1	–	204.9	–	289.9	–	310.7	–
	P_{GC}	156.3	–	206.5	–	377.0	–	432.7	–	692.9	–
	P_{GD}	192.9	–	273.6	–	464.3	–	570.6	–	805.6	–
22.4	P_{GA}	47.7	–	75.1	–	95.8	–	130.2	–	166.1	–
	P_{GB}	88.9	–	148.1	–	192.0	–	282.1	–	302.5	–
	P_{GC}	149.0	–	197.7	–	351.9	–	419.0	–	669.0	–
	P_{GD}	184.9	–	262.3	–	432.2	–	551.3	–	779.5	–
25	P_{GA}	46.7	–	72.2	85.9	94.7	111.4	127.4	146.6	160.5	186.6
	P_{GB}	86.9	–	141.6	166.5	189.5	218.9	272.9	310.3	290.1	332.9
	P_{GC}	145.8	–	189.1	215.4	346.6	305.0	406.8	536.3	635.9	715.7
	P_{GD}	180.5	–	251.3	287.6	427.5	399.8	532.4	675.9	738.2	831.9
28	P_{GA}	45.8	56.0	72.2	82.7	94.7	104.6	128.5	143.5	174.8	183.2
	P_{GB}	84.0	101.8	139.5	159.8	183.3	205.0	263.4	301.4	298.9	324.1
	P_{GC}	136.4	122.4	181.3	207.2	321.4	285.1	375.2	519.4	616.8	692.0
	P_{GD}	169.4	163.8	240.5	275.6	397.7	373.2	492.2	653.6	718.0	800.9
31.5	P_{GA}	44.8	53.8	69.3	79.3	93.4	104.0	125.0	139.8	167.0	176.3
	P_{GB}	82.1	97.6	133.6	153.0	180.9	202.6	254.9	291.9	284.5	308.8
	P_{GC}	133.2	117.4	173.4	197.9	317.3	281.4	362.7	500.0	583.9	654.2
	P_{GD}	165.3	156.9	230.3	263.8	390.9	368.1	476.7	630.6	680.2	763.0
35.5	P_{GA}	42.7	52.7	69.2	79.4	90.0	103.2	127.1	140.2	170.3	190.7
	P_{GB}	77.5	95.2	130.9	150.4	171.0	195.6	250.7	279.7	281.4	318.4
	P_{GC}	123.9	114.5	164.9	189.4	293.7	261.9	343.6	460.1	556.3	634.3
	P_{GD}	154.0	153.2	219.9	252.4	362.1	343.9	452.7	580.3	642.9	740.7
40	P_{GA}	41.9	51.4	66.4	76.2	89.1	102.0	123.2	135.9	162.7	181.9
	P_{GB}	75.9	92.0	125.5	143.9	168.4	193.0	242.7	271.1	268.1	302.3
	P_{GC}	121.4	107.2	157.4	181.5	289.0	259.1	330.5	445.1	523.4	602.8
	P_{GD}	150.7	144.2	210.2	241.9	356.7	339.3	437.3	561.9	609.4	699.3
45	P_{GA}	38.9	50.3	63.6	75.9	83.6	98.0	122.1	137.9	163.2	184.0
	P_{GB}	69.2	90.1	117.5	141.3	153.8	182.4	232.7	267.3	260.8	298.5
	P_{GC}	107.1	105.0	145.0	172.6	257.4	239.4	310.1	417.7	490.6	569.0
	P_{GD}	133.4	141.1	193.4	230.7	318.1	314.7	409.0	530.1	573.3	663.7
50	P_{GA}	38.1	47.9	60.9	72.8	82.6	96.8	118.1	133.8	155.3	175.5
	P_{GB}	67.7	85.1	112.6	135.3	152.2	179.5	225.3	258.0	247.9	283.8
	P_{GC}	104.4	98.0	139.2	165.0	253.9	235.6	299.6	403.8	465.3	540.8
	P_{GD}	130.2	131.8	185.1	221.1	313.3	310.6	395.1	513.2	542.0	628.4
56	P_{GA}	37.6	46.9	59.1	69.6	81.9	90.3	115.3	131.9	154.9	175.2
	P_{GB}	66.1	83.1	107.8	126.5	148.2	163.6	215.9	246.9	243.9	275.5
	P_{GC}	101.0	95.9	131.7	151.8	243.4	210.8	284.9	377.9	447.6	507.8
	P_{GD}	126.0	128.8	175.3	203.6	300.8	276.7	374.6	478.4	522.0	590.2
63	P_{GA}	35.6	43.4	57.4	66.7	79.4	89.4	113.8	127.7	157.3	166.4
	P_{GB}	61.3	75.7	102.7	121.6	139.8	161.9	206.9	239.1	241.2	261.0
	P_{GC}	90.7	85.2	122.0	145.0	222.9	207.6	264.3	364.7	426.1	479.5
	P_{GD}	113.3	114.7	162.8	194.7	274.3	272.9	347.3	462.9	495.5	557.8
71	P_{GA}	34.8	42.4	55.1	64.4	78.4	88.6	110.2	124.4	149.1	166.1
	P_{GB}	59.9	73.9	98.2	116.2	137.9	157.9	199.8	228.8	229.0	256.5
	P_{GC}	88.9	83.5	116.7	137.7	219.9	200.0	255.4	346.9	403.7	462.3
	P_{GD}	110.8	112.3	155.9	184.0	270.8	261.6	336.7	438.3	470.0	537.9
80	P_{GA}	–	41.8	–	62.5	–	85.6	–	121.9	–	167.6
	P_{GB}	–	72.1	–	110.4	–	148.6	–	219.1	–	253.6
	P_{GC}	–	80.8	–	128.0	–	184.1	–	318.8	–	438.5
	P_{GD}	–	108.6	–	171.3	–	240.3	–	405.0	–	511.5
90	P_{GA}	–	39.5	–	60.0	–	84.5	–	118.2	–	159.1
	P_{GB}	–	66.7	–	105.9	–	146.7	–	211.4	–	240.6
	P_{GC}	–	73.4	–	122.4	–	181.2	–	309.3	–	415.7
	P_{GD}	–	98.3	–	164.0	–	237.3	–	391.3	–	484.3
100	P_{GA}	–	38.7	–	–	–	–	–	–	–	–
	P_{GB}	–	65.4	–	–	–	–	–	–	–	–
	P_{GC}	–	71.8	–	–	–	–	–	–	–	–
	P_{GD}	–	96.4	–	–	–	–	–	–	–	–

For notes and legend for tables, see page 3/5

Design of the gear units

Overview tables

Type H3 – Thermal capacities
 $n_1 = 1800 \text{ rpm}$

Technical data (continued)

Thermal capacities P_G (kW) Type H3

i_N		Gear unit sizes									
		505	506	507	508	509	510	511	512	513	514
20	P_{GA}	50.0	–	76.8	–	96.1	–	117.2	–	143.9	–
	P_{GB}	103.0	–	169.7	–	222.2	–	308.3	–	318.9	–
	P_{GC}	172.8	–	225.8	–	412.1	–	467.3	–	748.7	–
	P_{GD}	218.7	–	307.1	–	516.6	–	630.2	–	883.0	–
22.4	P_{GA}	48.2	–	74.2	–	91.3	–	117.3	–	144.9	–
	P_{GB}	98.9	–	163.5	–	208.5	–	300.3	–	312.4	–
	P_{GC}	166.6	–	217.0	–	385.5	–	453.6	–	728.4	–
	P_{GD}	209.5	–	295.1	–	483.2	–	610.8	–	855.2	–
25	P_{GA}	47.3	–	71.7	85.5	90.8	106.6	115.2	132.7	141.8	165.4
	P_{GB}	96.8	–	157.0	184.0	206.2	237.6	291.8	329.6	300.3	344.0
	P_{GC}	161.9	–	208.4	235.5	379.8	329.9	440.6	580.8	694.6	774.1
	P_{GD}	204.3	–	282.9	322.4	476.0	444.7	591.0	748.9	814.0	915.0
28	P_{GA}	46.7	57.0	72.8	82.6	93.2	101.1	121.5	131.4	160.5	164.8
	P_{GB}	93.8	113.3	155.0	177.0	201.3	222.9	283.9	321.6	312.4	336.0
	P_{GC}	151.5	134.3	198.8	227.1	352.3	310.6	406.9	566.3	670.4	751.3
	P_{GD}	191.6	184.6	271.4	310.6	443.8	416.0	547.9	725.2	791.6	886.0
31.5	P_{GA}	45.8	54.7	70.0	79.5	92.3	100.4	118.5	129.2	154.6	159.9
	P_{GB}	91.7	108.4	148.7	169.5	198.6	220.5	275.2	311.7	297.9	321.8
	P_{GC}	148.4	128.7	190.5	217.2	346.8	304.9	393.4	545.4	638.8	715.3
	P_{GD}	187.5	176.9	259.3	297.3	437.4	411.4	530.2	700.4	751.0	839.3
35.5	P_{GA}	43.9	53.7	70.6	80.4	90.1	102.2	124.0	134.1	163.3	177.3
	P_{GB}	86.8	106.3	146.2	167.1	188.5	214.8	273.5	302.3	298.4	332.4
	P_{GC}	138.1	126.1	181.5	207.5	321.5	285.1	374.5	503.2	603.8	692.6
	P_{GD}	174.7	173.1	248.3	284.6	407.0	385.1	505.8	646.1	715.3	815.0
40	P_{GA}	42.9	52.8	67.7	77.2	89.2	101.5	120.6	130.5	156.4	170.5
	P_{GB}	84.7	102.9	140.0	160.2	186.2	211.9	264.3	292.6	283.6	317.2
	P_{GC}	134.8	118.4	173.5	198.6	318.1	282.2	362.3	485.3	575.1	655.6
	P_{GD}	170.4	163.6	237.8	273.0	401.2	379.4	488.7	624.1	677.8	773.7
45	P_{GA}	40.2	51.7	65.7	77.7	85.0	98.4	122.4	135.3	161.9	178.5
	P_{GB}	77.5	100.7	131.7	157.5	171.0	201.2	255.2	290.9	280.0	317.0
	P_{GC}	119.1	115.6	160.2	189.4	283.3	261.9	341.1	459.3	541.4	624.5
	P_{GD}	151.4	159.6	219.3	260.9	357.7	352.1	458.5	594.9	634.8	736.6
50	P_{GA}	39.5	49.4	63.0	74.4	84.3	97.5	118.7	131.8	154.9	170.3
	P_{GB}	76.0	95.0	126.1	150.9	168.4	198.5	247.2	281.8	266.8	301.0
	P_{GC}	116.9	107.5	153.2	181.3	280.0	258.3	328.7	445.7	511.4	590.5
	P_{GD}	148.3	148.8	209.9	249.6	352.5	348.3	442.9	574.4	604.8	696.0
56	P_{GA}	39.2	48.4	61.5	72.0	84.7	92.3	117.5	132.8	157.1	175.1
	P_{GB}	74.1	92.9	121.0	141.9	165.4	181.9	238.7	271.1	263.7	295.6
	P_{GC}	112.8	105.4	145.7	167.9	269.5	231.3	314.1	414.9	495.3	556.1
	P_{GD}	143.2	145.7	198.4	230.1	339.4	310.5	421.7	536.5	581.0	653.9
63	P_{GA}	37.5	45.1	60.1	69.2	82.9	91.4	117.1	128.7	162.2	167.0
	P_{GB}	69.1	84.7	115.4	135.8	156.8	179.5	229.6	262.0	263.1	281.8
	P_{GC}	101.5	94.1	134.7	160.4	247.6	228.5	292.1	401.6	472.2	528.4
	P_{GD}	129.2	129.9	184.4	220.6	311.1	306.9	390.9	518.3	555.5	620.4
71	P_{GA}	36.7	44.2	57.9	67.3	81.9	91.6	113.7	127.1	154.0	168.8
	P_{GB}	67.6	82.9	111.0	130.5	154.6	175.9	222.4	252.9	250.2	278.6
	P_{GC}	99.4	91.9	129.8	152.1	243.5	220.1	282.4	382.0	446.5	508.8
	P_{GD}	126.3	127.2	177.4	209.1	306.3	295.1	379.3	491.7	525.7	598.9
80	P_{GA}	–	43.8	–	65.7	–	89.6	–	126.5	–	173.1
	P_{GB}	–	81.2	–	124.3	–	166.4	–	243.3	–	276.7
	P_{GC}	–	89.3	–	140.9	–	203.4	–	353.7	–	484.1
	P_{GD}	–	123.5	–	194.0	–	271.9	–	456.3	–	572.2
90	P_{GA}	–	41.6	–	63.0	–	88.5	–	122.4	–	164.8
	P_{GB}	–	75.2	–	119.2	–	164.0	–	234.8	–	262.8
	P_{GC}	–	81.1	–	135.4	–	200.5	–	342.2	–	459.6
	P_{GD}	–	111.9	–	186.5	–	268.6	–	440.6	–	541.6
100	P_{GA}	–	40.7	–	–	–	–	–	–	–	–
	P_{GB}	–	73.7	–	–	–	–	–	–	–	–
	P_{GC}	–	79.4	–	–	–	–	–	–	–	–
	P_{GD}	–	109.4	–	–	–	–	–	–	–	–

For notes and legend for tables, see page 3/5

Design of the gear units

Overview tables

Type H4
Nominal power ratings, gear unit sizes 507 to 514

Technical data

Nominal power ratings P_{2N} (kW) for H4

i_N	n_1	n_2	Gear unit sizes										
			504	505	506	507	508	509	510	511	512	513	514
80	1800	23	–	–	–	50	–	83	–	142	–	233	–
	1500	19	–	–	–	41	–	69	–	118	–	194	–
	1200	15	–	–	–	33	–	56	–	94	–	155	–
	1000	13	–	–	–	28	–	46	–	79	–	129	–
90	1800	20	–	–	–	44	–	74	–	126	–	205	–
	1500	17	–	–	–	37	–	62	–	105	–	171	–
	1200	13	–	–	–	30	–	50	–	84	–	137	–
	1000	11	–	–	–	25	–	41	–	70	–	114	–
100	1800	18	–	–	–	40	52	65	87	112	146	184	225
	1500	15	–	–	–	33	43	54	72	93	122	154	188
	1200	12	–	–	–	27	34	43	58	75	97	123	150
	1000	10	–	–	–	22	29	36	48	62	81	102	125
112	1800	16	–	–	–	35	46	60	77	104	130	161	199
	1500	13	–	–	–	30	38	50	64	87	109	134	166
	1200	11	–	–	–	24	31	40	52	69	87	108	133
	1000	9	–	–	–	20	26	33	43	58	72	90	110
125	1800	14	–	–	–	32	41	53	68	92	116	145	178
	1500	12	–	–	–	27	34	44	56	77	96	121	149
	1200	10	–	–	–	22	28	35	45	62	77	97	119
	1000	8	–	–	–	18	23	29	38	51	64	80	99
140	1800	13	–	–	–	29	37	49	62	83	108	132	156
	1500	11	–	–	–	24	31	41	52	70	90	110	130
	1200	9	–	–	–	19	25	33	42	56	72	88	104
	1000	7	–	–	–	16	20	27	35	46	60	73	87
160	1800	11	–	–	–	26	34	43	55	74	95	119	140
	1500	9	–	–	–	22	28	36	46	62	79	99	117
	1200	8	–	–	–	17	22	29	36	49	64	79	93
	1000	6	–	–	–	14	19	24	30	41	53	66	78
180	1800	10	–	–	–	23	30	39	51	64	86	104	128
	1500	8	–	–	–	19	25	33	43	54	72	87	107
	1200	7	–	–	–	15	20	26	34	43	58	70	85
	1000	6	–	–	–	13	17	22	28	36	48	58	71
200	1800	9	–	–	–	20	27	34	45	57	77	94	115
	1500	8	–	–	–	17	22	28	37	48	64	78	96
	1200	6	–	–	–	13	18	23	30	38	51	63	77
	1000	5	–	–	–	11	15	19	25	32	43	52	64
224	1800	8	–	–	–	18	24	30	41	51	67	82	101
	1500	7	–	–	–	15	20	25	34	42	55	68	84
	1200	5	–	–	–	12	16	20	27	34	44	55	67
	1000	4	–	–	–	9.7	13	17	23	28	37	46	56
250	1800	7	–	–	–	16	21	27	35	45	59	72	91
	1500	6	–	–	–	13	17	22	30	38	49	60	76
	1200	5	–	–	–	10	14	18	24	30	39	48	61
	1000	4	–	–	–	8.7	12	15	20	25	33	40	50
280	1800	6	–	–	–	14	18	24	31	40	53	65	80
	1500	5	–	–	–	11	15	20	26	34	44	54	66
	1200	4	–	–	–	9.2	12	16	21	27	35	43	53
	1000	4	–	–	–	7.6	10	13	17	22	29	36	44
315	1800	6	–	–	–	–	16	21	28	36	47	58	70
	1500	5	–	–	–	–	14	17	23	30	39	49	58
	1200	4	–	–	–	–	11	14	19	24	31	39	47
	1000	3	–	–	–	–	9.0	12	16	20	26	32	39
355	1800	5	–	–	–	–	14	–	25	–	42	–	63
	1500	4	–	–	–	–	12	–	20	–	35	–	52
	1200	3	–	–	–	–	9.5	–	16	–	28	–	42
	1000	3	–	–	–	–	8.0	–	14	–	23	–	35
400	1800	5	–	–	–	–	–	–	22	–	37	–	57
	1500	4	–	–	–	–	–	–	18	–	31	–	47
	1200	3	–	–	–	–	–	–	15	–	25	–	38
	1000	3	–	–	–	–	–	–	12	–	21	–	31

Design of the gear units

Overview tables

Type H4 – Nominal output torques Gear unit sizes 507 to 514

Technical data (continued)

Nominal output torques T_{2N} (kNm) Type H4

i_N	Gear unit sizes											Type
	504	505	506	507	508	509	510	511	512	513	514	
6.3	7	11.6	–	21.5	–	37	–	63.5	–	101.5	–	H2
7.1	7	11.6	–	21.5	–	37	–	63.5	–	101.5	–	
8	7	11.6	–	21.5	28.3	37	48.5	63.5	81	101.5	125	
9	7	11.6	16.2	21.5	28.3	37	48.5	63.5	81	101.5	125	
10	7	11.6	16.2	21.5	28.3	37	48.5	63.5	81	101.5	125	
11.2	7	11.6	16.2	21.5	28.3	37	48.5	63.5	81	101.5	125	
12.5	7	11.6	16.2	21.5	28.3	37	48.5	63.5	81	101.5	125	
14	7	11.6	16.2	21.5	28.3	37	48.5	63.5	81	101.5	125	
16	7	11.6	16.2	21.5	28.3	37	48.5	63.5	81	101.5	125	
18	7	11.6	16.2	21.5	28.3	37	48.5	63.5	81	101.5	125	
20	7	11.6	16.2	21.5	28.3	37	48.5	63.5	81	101.5	125	
22.4	–	11.6	16.2	21.5	28.3	37	48.5	63.5	81	101.5	125	
25	–	11.6	16.2	21.5	28.3	37	48.5	63.5	81	101.5	125	
28	–	11.6	16.2	21.5	28.3	37	48.5	63.5	81	101.5	125	
31.5	–	11.6	16.2	21.5	28.3	37	48.5	63.5	81	101.5	125	
35.5	–	11.6	16.2	21.5	28.3	37	48.5	63.5	81	101.5	125	
40	–	11.6	16.2	21.5	28.3	37	48.5	63.5	81	101.5	125	
45	–	11.6	16.2	21.5	28.3	37	48.5	63.5	81	101.5	125	
50	–	11.6	16.2	21.5	28.3	37	48.5	63.5	81	101.5	125	
56	–	11.6	16.2	21.5	28.3	37	48.5	63.5	81	101.5	125	
63	–	11.6	16.2	21.5	28.3	37	48.5	63.5	81	101.5	125	
71	–	11.6	16.2	21.5	28.3	37	48.5	63.5	81	101.5	125	
80	–	–	16.2	21.5	28.3	37	48.5	63.5	81	101.5	125	
90	–	–	16.2	21.5	28.3	37	48.5	63.5	81	101.5	125	
100	–	–	16.2	21.5	28.3	37	48.5	63.5	81	101.5	125	
112	–	–	–	21.5	28.3	37	48.5	63.5	81	101.5	125	
125	–	–	–	21.5	28.3	37	48.5	63.5	81	101.5	125	
140	–	–	–	21.5	28.3	37	48.5	63.5	81	101.5	125	
160	–	–	–	21.5	28.3	37	48.5	63.5	81	101.5	125	
180	–	–	–	21.5	28.3	37	48.5	63.5	81	101.5	125	
200	–	–	–	21.5	28.3	37	48.5	63.5	81	101.5	125	
224	–	–	–	21.5	28.3	37	48.5	63.5	81	101.5	125	
250	–	–	–	21.5	28.3	37	48.5	63.5	81	101.5	125	
280	–	–	–	21.5	28.3	37	48.5	63.5	81	101.5	125	
315	–	–	–	–	28.3	37	48.5	63.5	81	101.5	125	
355	–	–	–	–	28.3	–	48.5	–	81	–	125	
400	–	–	–	–	–	–	48.5	–	81	–	125	

Type **H2**, see page 3/11

Type **H3**, see page 3/17

Design of the gear units

Overview tables

Type H4 – Thermal capacities
 $n_1 = 1000 \text{ rpm}$, $n_1 = 1200 \text{ rpm}$

Technical data (continued)

Thermal capacities P_G (kW) Type H4
 $n_1 = 1000 \text{ rpm}$

i_N		Gear unit sizes							
		507	508	509	510	511	512	513	514
80	P_{GA}	42.4	–	59.8	–	90.5	–	122.1	–
90	P_{GA}	40.8	–	57.5	–	87.3	–	115.6	–
100	P_{GA}	39.8	46.0	55.9	64.2	83.9	96.8	113.2	129.6
112	P_{GA}	38.2	44.2	54.0	61.7	81.8	93.2	108.4	122.6
125	P_{GA}	36.8	43.2	52.5	60.0	78.7	89.6	106.0	120.1
140	P_{GA}	35.4	41.5	49.9	58.0	76.5	87.5	100.9	114.8
160	P_{GA}	34.3	39.9	48.6	56.3	73.5	84.0	98.8	112.4
180	P_{GA}	32.9	38.4	45.6	53.6	69.3	81.8	91.9	106.9
200	P_{GA}	31.6	37.1	44.3	52.1	66.6	78.6	90.1	104.7
224	P_{GA}	29.6	35.7	42.8	48.8	63.8	74.0	86.0	97.3
250	P_{GA}	28.5	34.2	40.0	47.5	61.0	71.1	80.9	95.3
280	P_{GA}	27.2	32.1	38.9	45.9	58.7	68.1	79.2	91.1
315	P_{GA}	–	30.9	37.2	43.0	56.7	65.3	76.0	85.6
355	P_{GA}	–	29.5	–	41.8	–	62.8	–	83.7
400	P_{GA}	–	–	–	39.9	–	60.6	–	80.4

Thermal capacities P_G (kW) Type H4
 $n_1 = 1200 \text{ rpm}$

i_N		Gear unit sizes							
		507	508	509	510	511	512	513	514
80	P_{GA}	44.7	–	63.2	–	95.3	–	128.1	–
90	P_{GA}	43.0	–	60.7	–	91.8	–	121.4	–
100	P_{GA}	42.1	48.6	59.1	67.9	88.3	101.9	119.0	136.2
112	P_{GA}	40.4	46.7	57.1	65.2	86.4	98.3	114.1	129.1
125	P_{GA}	39.0	45.6	55.5	63.5	83.1	94.6	111.8	126.2
140	P_{GA}	37.4	43.9	52.9	61.4	81.0	92.4	106.6	121.2
160	P_{GA}	36.5	42.3	51.5	59.7	77.8	88.8	104.4	118.6
180	P_{GA}	35.0	40.7	48.5	56.9	73.5	86.5	97.6	113.0
200	P_{GA}	33.6	39.5	47.2	55.3	70.6	83.2	95.6	110.6
224	P_{GA}	31.5	38.0	45.6	52.0	67.9	78.5	91.4	103.3
250	P_{GA}	30.3	36.4	42.2	50.7	64.9	75.5	86.1	101.2
280	P_{GA}	29.0	34.1	41.1	48.9	62.4	72.4	84.4	96.7
315	P_{GA}	–	32.8	39.3	45.3	60.3	69.3	81.0	91.1
355	P_{GA}	–	31.4	–	44.1	–	66.6	–	89.2
400	P_{GA}	–	–	–	42.2	–	64.3	–	85.6

For notes and legend for tables, see page 3/5

Design of the gear units

Overview tables

Type H4 – Thermal capacities
 $n_1 = 1500 \text{ rpm}$, $n_1 = 1800 \text{ rpm}$

Technical data (continued)

Thermal capacities P_G (kW) Type H4
 $n_1 = 1500 \text{ rpm}$

i_N		Gear unit sizes							
		507	508	509	510	511	512	513	514
80	P_{GA}	47.5	–	67.1	–	100.5	–	134.7	–
90	P_{GA}	45.6	–	64.6	–	97.2	–	127.8	–
100	P_{GA}	44.7	51.7	62.9	72.2	93.7	107.9	125.2	143.4
112	P_{GA}	43.0	49.6	60.9	69.5	91.7	104.2	120.8	135.9
125	P_{GA}	41.6	48.6	59.3	67.6	88.4	100.2	118.4	133.2
140	P_{GA}	39.9	46.7	56.6	65.5	86.3	98.2	113.1	128.5
160	P_{GA}	39.2	45.2	55.1	63.7	82.9	94.6	110.9	125.8
180	P_{GA}	37.7	43.3	52.2	60.9	78.6	92.3	104.5	120.2
200	P_{GA}	36.2	42.5	50.9	59.2	75.5	88.8	102.3	117.8
224	P_{GA}	34.0	40.8	49.1	56.1	72.9	84.0	97.8	110.6
250	P_{GA}	32.7	39.2	45.6	54.6	70.0	80.8	92.6	108.4
280	P_{GA}	31.3	36.8	44.4	52.7	67.3	77.9	90.7	103.6
315	P_{GA}	–	35.4	42.4	49.0	65.0	74.7	87.1	98.0
355	P_{GA}	–	33.9	–	47.6	–	71.9	–	95.9
400	P_{GA}	–	–	–	45.6	–	69.4	–	92.1

Thermal capacities P_G (kW) Type H4
 $n_1 = 1800 \text{ rpm}$

i_N		Gear unit sizes							
		507	508	509	510	511	512	513	514
80	P_{GA}	49.5	–	70.1	–	104.5	–	138.6	–
90	P_{GA}	47.6	–	67.5	–	101.0	–	131.7	–
100	P_{GA}	46.7	54.0	65.7	75.5	97.4	112.1	129.6	148.0
112	P_{GA}	44.9	51.8	63.8	72.8	95.7	108.3	125.6	140.7
125	P_{GA}	43.5	50.9	62.2	70.8	92.4	104.6	123.0	138.3
140	P_{GA}	41.8	48.9	59.5	68.7	90.3	102.8	118.2	133.6
160	P_{GA}	41.4	47.3	57.9	66.9	86.9	98.9	115.9	131.1
180	P_{GA}	39.8	45.5	55.3	64.0	82.5	96.8	109.8	125.8
200	P_{GA}	38.3	44.9	53.9	62.3	79.4	93.2	107.6	123.1
224	P_{GA}	36.0	43.2	52.1	59.4	76.8	88.3	103.1	116.5
250	P_{GA}	34.6	41.5	48.4	57.8	74.2	85.0	97.8	114.1
280	P_{GA}	33.1	39.1	47.1	56.0	71.4	82.2	95.8	109.2
315	P_{GA}	–	37.5	45.1	52.0	69.0	79.2	92.0	103.5
355	P_{GA}	–	35.9	–	50.6	–	76.3	–	101.5
400	P_{GA}	–	–	–	48.4	–	73.6	–	97.5

Design of the gear units

Overview tables

Type B3
Nominal power ratings, gear unit sizes 504 to 514

Technical data

Nominal power ratings P_{2N} (kW) for B3

i_N	n_1	n_2	Gear unit sizes										
			504	505	506	507	508	509	510	511	512	513	514
14	1800	129	–	157	–	294	–	491	–	864	–	1394	–
	1500	107	–	131	–	245	–	409	–	720	–	1162	–
	1200	86	–	104	–	196	–	327	–	576	–	929	–
	1000	71	–	87	–	163	–	273	–	480	–	774	–
16	1800	113	86	139	–	254	–	433	–	765	–	1228	–
	1500	94	72	116	–	212	–	360	–	637	–	1023	–
	1200	75	58	92	–	170	–	288	–	510	–	819	–
	1000	63	48	77	–	141	–	240	–	425	–	682	–
18	1800	100	74	124	–	227	305	382	510	664	892	1091	1350
	1500	83	62	103	–	189	254	318	425	554	743	909	1125
	1200	67	49	83	–	151	203	254	340	443	595	728	900
	1000	56	41	69	–	126	169	212	284	369	495	606	750
20	1800	90	67	108	158	201	264	343	450	593	790	956	1189
	1500	75	55	90	132	168	220	286	375	494	658	796	991
	1200	60	44	72	105	134	176	228	300	395	526	637	793
	1000	50	37	60	88	112	146	190	250	330	439	531	661
22.4	1800	80	59	97	140	179	236	297	397	516	686	849	1057
	1500	67	49	81	117	149	196	247	330	430	572	707	881
	1200	54	40	65	93	119	157	198	264	344	457	566	705
	1000	45	33	54	78	99	131	165	220	287	381	471	587
25	1800	72	52	85	125	159	209	267	356	461	612	743	926
	1500	60	44	71	104	132	174	222	297	384	510	619	771
	1200	48	35	57	83	106	139	178	237	307	408	495	617
	1000	40	29	47	70	88	116	148	198	256	340	413	514
28	1800	64	47	78	110	143	185	236	308	400	533	679	822
	1500	54	39	65	91	119	155	197	257	333	444	566	685
	1200	43	31	52	73	95	124	157	206	266	355	453	548
	1000	36	26	43	61	80	103	131	171	222	296	377	457
31.5	1800	57	42	68	99	127	165	212	277	357	476	595	720
	1500	48	35	57	82	106	137	177	231	297	397	496	600
	1200	38	28	46	66	85	110	141	185	238	317	397	480
	1000	32	23	38	55	70	91	118	154	198	265	330	400
35.5	1800	51	37	63	86	116	149	192	245	334	413	548	658
	1500	42	31	52	72	96	124	160	204	278	344	457	548
	1200	34	25	42	57	77	99	128	163	222	275	366	439
	1000	28	21	35	48	64	83	107	136	185	229	305	366
40	1800	45	34	55	79	103	132	172	220	298	368	480	576
	1500	38	28	46	66	85	110	144	183	248	307	400	480
	1200	30	23	37	53	68	88	115	147	199	246	320	384
	1000	25	19	31	44	57	73	96	122	166	205	267	320
45	1800	40	30	49	69	90	120	150	199	261	345	428	531
	1500	33	25	41	57	75	100	125	166	217	287	357	443
	1200	27	20	33	46	60	80	100	133	174	230	285	354
	1000	22	17	27	38	50	67	83	111	145	191	238	295
50	1800	36	26	43	64	80	106	135	179	233	308	375	465
	1500	30	22	36	53	67	89	112	149	194	256	313	387
	1200	24	18	29	42	53	71	90	119	155	205	250	310
	1000	20	15	24	35	45	59	75	99	129	171	208	258
56	1800	32	24	39	56	73	94	122	156	211	269	340	415
	1500	27	20	33	46	60	78	102	130	176	224	284	346
	1200	21	16	26	37	48	62	81	104	141	179	227	277
	1000	18	13	22	31	40	52	68	86	117	150	189	230
63	1800	29	21	–	50	–	83	–	140	–	240	–	363
	1500	24	18	–	41	–	69	–	116	–	200	–	303
	1200	19	14	–	33	–	55	–	93	–	160	–	242
	1000	16	12	–	28	–	46	–	78	–	134	–	202
71	1800	25	–	–	44	–	75	–	127	–	218	–	329
	1500	21	–	–	36	–	63	–	106	–	182	–	275
	1200	17	–	–	29	–	50	–	84	–	145	–	220
	1000	14	–	–	24	–	42	–	70	–	121	–	183
80	1800	23	–	–	39	–	–	–	–	–	–	–	–
	1500	19	–	–	33	–	–	–	–	–	–	–	–
	1200	15	–	–	26	–	–	–	–	–	–	–	–
	1000	13	–	–	22	–	–	–	–	–	–	–	–

Design of the gear units

Overview tables

Type B3 – Nominal output torques
Gear unit sizes 504 to 514

Technical data (continued)

Nominal output torques T_{2N} (kNm) Type B3

i_N	Gear unit sizes											Type
	504	505	506	507	508	509	510	511	512	513	514	
14	–	11.6	–	21.5	–	37	–	63.5	–	101.5	–	B3
16	7	11.6	–	21.5	–	37	–	63.5	–	101.5	–	
18	7	11.6	–	21.5	28.3	37	48.5	63.5	81	101.5	125	
20	7	11.6	16.2	21.5	28.3	37	48.5	63.5	81	101.5	125	
22.4	7	11.6	16.2	21.5	28.3	37	48.5	63.5	81	101.5	125	
25	7	11.6	16.2	21.5	28.3	37	48.5	63.5	81	101.5	125	
28	7	11.6	16.2	21.5	28.3	37	48.5	63.5	81	101.5	125	
31.5	7	11.6	16.2	21.5	28.3	37	48.5	63.5	81	101.5	125	
35.5	7	11.6	16.2	21.5	28.3	37	48.5	63.5	81	101.5	125	
40	7	11.6	16.2	21.5	28.3	37	48.5	63.5	81	101.5	125	
45	7	11.6	16.2	21.5	28.3	37	48.5	63.5	81	101.5	125	
50	7	11.6	16.2	21.5	28.3	37	48.5	63.5	81	101.5	125	
56	7	11.6	16.2	21.5	28.3	37	48.5	63.5	81	101.5	125	
63	7	11.6	16.2	21.5	28.3	37	48.5	63.5	81	101.5	125	
71	–	11.6	16.2	21.5	28.3	37	48.5	63.5	81	101.5	125	
80	–	11.6	16.2	21.5	28.3	37	48.5	63.5	81	101.5	125	
90	–	11.6	16.2	21.5	28.3	37	48.5	63.5	81	101.5	125	
100	–	11.6	16.2	21.5	28.3	37	48.5	63.5	81	101.5	125	
112	–	11.6	16.2	21.5	28.3	37	48.5	63.5	81	101.5	125	
125	–	11.6	16.2	21.5	28.3	37	48.5	63.5	81	101.5	125	
140	–	11.6	16.2	21.5	28.3	37	48.5	63.5	81	101.5	125	
160	–	11.6	16.2	21.5	28.3	37	48.5	63.5	81	101.5	125	
180	–	11.6	16.2	21.5	28.3	37	48.5	63.5	81	101.5	125	
200	–	11.6	16.2	21.5	28.3	37	48.5	63.5	81	101.5	125	
224	–	11.6	16.2	21.5	28.3	37	48.5	63.5	81	101.5	125	
250	–	11.6	16.2	21.5	28.3	37	48.5	63.5	81	101.5	125	
280	–	11.6	16.2	21.5	28.3	37	48.5	63.5	81	101.5	125	
315	–	–	16.2	–	28.3	–	48.5	–	81	–	125	
355	–	–	16.2	–	28.3	–	48.5	–	81	–	125	

3

Type B4, see page 3/33

Technical data (continued)*Thermal capacities P_G (kW) Type B3*

<i>i</i> _N		Gear unit sizes										
		504	505	506	507	508	509	510	511	512	513	514
14	P_{GA}	–	47.9	–	68.2	–	86.8	–	113.5	–	132.5	–
	P_{GB}	–	97.5	–	139.7	–	227.5	–	312.6	–	413.7	–
	P_{GC}	–	183.3	–	218.5	–	399.1	–	457.1	–	755.4	–
	P_{GD}	–	224.8	–	281.7	–	517.1	–	630.0	–	987.3	–
16	P_{GA}	34.8	45.5	–	67.2	–	86.4	–	111.7	–	131.5	–
	P_{GB}	73.1	92.1	–	136.8	–	224.0	–	302.5	–	399.2	–
	P_{GC}	81.5	171.9	–	214.0	–	393.0	–	441.5	–	725.4	–
	P_{GD}	116.1	210.7	–	274.7	–	508.4	–	607.0	–	947.1	–
18	P_{GA}	33.3	43.8	–	65.1	75.9	82.1	96.1	109.9	127.5	130.3	151.5
	P_{GB}	69.6	88.5	–	131.6	150.3	210.6	241.5	293.5	332.4	388.4	440.2
	P_{GC}	77.6	165.2	–	206.7	228.1	367.0	319.5	427.5	567.8	703.2	779.1
	P_{GD}	110.4	202.4	–	263.8	294.3	477.0	448.4	586.6	742.8	914.0	1020.8
20	P_{GA}	32.2	42.9	54.9	62.8	74.6	81.5	95.4	108.3	124.8	126.5	149.4
	P_{GB}	67.6	85.9	106.3	127.3	147.7	205.8	235.5	285.4	321.2	370.9	424.2
	P_{GC}	74.8	161.1	140.1	197.9	223.0	363.4	314.0	414.0	546.7	665.9	747.8
	P_{GD}	106.7	197.4	185.7	253.9	287.2	467.4	438.2	568.7	715.6	870.8	977.9
22.4	P_{GA}	31.0	40.4	51.8	59.9	72.0	77.1	90.6	108.4	122.6	131.8	147.4
	P_{GB}	58.6	78.6	100.0	117.8	142.3	185.5	221.2	266.5	312.3	353.8	411.8
	P_{GC}	71.9	138.2	131.4	169.6	214.7	310.9	295.5	364.6	529.1	600.6	724.0
	P_{GD}	96.7	170.8	174.3	221.0	275.8	404.1	410.6	503.9	691.5	785.1	943.6
25	P_{GA}	29.0	39.6	49.8	57.8	69.4	76.1	89.9	105.6	119.7	127.1	142.3
	P_{GB}	53.7	77.0	95.8	113.1	136.5	182.9	217.9	259.1	303.3	336.4	392.6
	P_{GC}	62.1	135.2	126.1	163.0	205.5	307.2	291.4	353.4	510.8	571.0	691.2
	P_{GD}	84.5	166.7	166.9	211.7	264.8	398.2	404.8	489.8	669.9	746.7	897.1
28	P_{GA}	28.0	37.5	48.8	55.4	66.2	70.3	84.5	101.4	118.8	127.9	145.9
	P_{GB}	51.6	71.8	93.8	106.7	126.1	163.0	196.7	239.2	283.2	324.2	373.4
	P_{GC}	59.7	122.3	123.3	147.4	176.7	260.5	250.0	309.1	448.0	526.5	618.3
	P_{GD}	81.2	151.4	163.5	193.2	230.3	340.3	349.5	432.0	592.5	691.0	808.5
31.5	P_{GA}	26.8	36.7	45.7	53.4	63.7	69.6	83.5	98.8	115.9	122.8	139.7
	P_{GB}	48.7	70.3	85.7	102.5	121.3	160.7	193.6	232.4	274.9	309.7	355.6
	P_{GC}	54.7	119.3	106.6	142.1	170.1	256.4	247.0	301.7	434.2	500.1	588.6
	P_{GD}	74.7	147.8	142.5	185.6	221.4	336.6	344.5	419.7	572.6	658.0	771.2
35.5	P_{GA}	25.8	33.0	44.7	49.0	61.1	63.3	76.6	92.8	110.7	116.3	140.6
	P_{GB}	46.9	62.0	83.9	92.5	114.3	143.3	172.9	212.7	252.8	282.5	341.4
	P_{GC}	52.6	99.4	104.6	123.0	154.0	221.9	209.4	263.5	381.8	438.4	541.4
	P_{GD}	71.9	124.5	139.7	161.9	202.3	291.7	295.8	370.5	504.6	583.3	713.4
40	P_{GA}	24.0	32.4	42.2	47.3	58.8	62.6	76.0	90.3	107.9	111.7	134.2
	P_{GB}	43.1	60.8	78.0	89.0	109.8	141.6	170.4	206.7	245.6	270.9	325.8
	P_{GC}	47.6	97.5	94.8	118.7	148.7	219.3	207.0	256.9	370.7	420.7	513.0
	P_{GD}	65.1	121.7	127.1	156.2	194.1	288.1	291.5	360.6	490.5	556.3	678.0
45	P_{GA}	23.1	28.8	41.3	42.7	53.8	55.4	69.1	82.4	101.0	125.4	126.8
	P_{GB}	41.5	53.0	76.4	78.8	98.8	121.9	151.7	183.4	224.8	271.3	297.5
	P_{GC}	45.7	80.8	92.6	100.4	128.6	180.6	179.2	217.8	323.5	398.7	454.1
	P_{GD}	62.6	101.7	124.2	132.8	169.5	239.2	253.9	308.7	433.1	524.6	600.1
50	P_{GA}	20.1	28.3	37.2	41.3	51.9	54.7	68.4	80.4	98.2	120.4	121.5
	P_{GB}	35.4	51.9	67.4	76.3	95.4	120.6	150.3	178.7	218.8	259.2	284.7
	P_{GC}	37.0	79.2	78.2	96.6	123.9	178.3	176.9	212.7	315.6	380.0	432.3
	P_{GD}	51.1	99.8	105.7	128.4	163.0	236.2	250.5	300.7	420.9	501.5	573.4
56	P_{GA}	19.4	27.0	36.4	41.4	46.7	57.1	60.4	84.6	89.4	115.4	135.0
	P_{GB}	34.2	48.9	66.0	74.7	84.3	119.5	129.5	177.6	194.1	245.8	284.7
	P_{GC}	35.7	73.7	76.6	94.0	104.8	174.4	146.1	209.1	265.8	353.9	410.0
	P_{GD}	49.3	92.8	103.4	124.2	138.8	229.2	208.6	292.8	358.5	466.4	540.6
63	P_{GA}	20.0	–	32.3	–	45.2	–	59.8	–	87.3	–	128.9
	P_{GB}	34.5	–	57.5	–	81.6	–	128.0	–	188.8	–	272.3
	P_{GC}	36.1	–	64.0	–	101.1	–	144.6	–	260.0	–	391.7
	P_{GD}	49.5	–	86.9	–	134.0	–	206.3	–	349.5	–	515.6
71	P_{GA}	–	–	31.7	–	45.3	–	61.7	–	91.5	–	123.8
	P_{GB}	–	–	56.5	–	79.8	–	126.5	–	187.8	–	258.1
	P_{GC}	–	–	62.9	–	98.4	–	142.0	–	254.7	–	364.2
	P_{GD}	–	–	85.4	–	129.6	–	200.7	–	340.0	–	480.7
80	P_{GA}	–	–	30.1	–	–	–	–	–	–	–	–
	P_{GB}	–	–	53.1	–	–	–	–	–	–	–	–
	P_{GC}	–	–	58.6	–	–	–	–	–	–	–	–
	P_{GD}	–	–	79.8	–	–	–	–	–	–	–	–

For notes and legend for tables, see page 3/5

Design of the gear units

Overview tables

Type B4 Nominal power ratings, gear unit sizes 505 to 514

Technical data

Nominal power ratings P_{2N} (kW) for B4

i_N	n_1	n_2	Gear unit sizes										
			504	505	506	507	508	509	510	511	512	513	514
63	1800	29	–	35	–	63	–	108	–	182	–	298	–
	1500	24	–	29	–	52	–	90	–	152	–	248	–
	1200	19	–	23	–	42	–	72	–	122	–	199	–
	1000	16	–	19	–	35	–	60	–	101	–	165	–
71	1800	25	–	31	–	57	–	97	–	163	–	263	–
	1500	21	–	26	–	47	–	81	–	136	–	219	–
	1200	17	–	21	–	38	–	64	–	109	–	175	–
	1000	14	–	17	–	31	–	54	–	91	–	146	–
80	1800	23	–	27	–	50	65	85	113	145	188	236	289
	1500	19	–	23	–	42	54	71	94	120	157	197	240
	1200	15	–	18	–	34	43	56	75	96	126	157	192
	1000	13	–	15	–	28	36	47	63	80	105	131	160
90	1800	20	–	24	35	44	59	76	100	128	168	204	255
	1500	17	–	20	29	37	49	63	84	107	140	170	212
	1200	13	–	16	23	30	39	51	67	86	112	136	170
	1000	11	–	14	19	25	33	42	56	71	94	114	141
100	1800	18	–	21	31	40	52	67	88	114	149	183	229
	1500	15	–	18	26	33	44	55	73	95	124	153	191
	1200	12	–	14	21	26	35	44	59	76	100	122	152
	1000	10	–	12	17	22	29	37	49	63	83	102	127
112	1800	16	–	20	27	36	46	61	79	103	133	162	198
	1500	13	–	16	23	30	38	51	66	86	111	135	165
	1200	11	–	13	18	24	31	41	53	68	88	108	132
	1000	8.9	–	11	15	20	26	34	44	57	74	90	110
125	1800	14	–	17	25	32	41	53	69	91	118	146	178
	1500	12	–	14	21	26	34	44	58	76	98	122	148
	1200	10	–	11	16	21	27	36	46	61	78	97	118
	1000	8.0	–	9.5	14	18	23	30	38	51	65	81	99
140	1800	13	–	16	21	29	37	49	63	83	106	132	157
	1500	11	–	13	18	24	31	41	53	69	88	110	131
	1200	8.6	–	11	14	19	25	33	42	55	71	88	105
	1000	7.1	–	8.8	12	16	21	27	35	46	59	73	87
160	1800	11	–	14	20	26	33	43	55	74	94	119	141
	1500	9.4	–	11	16	21	27	36	46	61	78	99	118
	1200	7.5	–	9.2	13	17	22	29	37	49	63	79	94
	1000	6.3	–	7.6	11	14	18	24	31	41	52	66	79
180	1800	10	–	12	17	22	30	38	51	65	86	103	128
	1500	8.3	–	10	14	19	25	32	43	54	71	86	107
	1200	6.7	–	8.2	12	15	20	26	34	43	57	69	85
	1000	5.6	–	6.8	9.6	12	17	21	28	36	48	57	71
200	1800	9.0	–	11	16	20	27	34	45	57	76	93	115
	1500	7.5	–	9.0	13	17	22	28	37	48	63	77	96
	1200	6.0	–	7.2	11	13	18	22	30	38	51	62	77
	1000	5.0	–	6.0	8.8	11	15	19	25	32	42	51	64
224	1800	8.0	–	9.8	14	18	23	31	40	52	67	84	100
	1500	6.7	–	8.2	12	15	19	25	33	44	56	70	83
	1200	5.4	–	6.5	9.3	12	16	20	27	35	45	56	67
	1000	4.5	–	5.4	7.7	10	13	17	22	29	37	47	55
250	1800	7.2	–	8.5	12	16	21	27	35	46	59	74	90
	1500	6.0	–	7.1	10	13	17	22	29	38	49	61	75
	1200	4.8	–	5.7	8.3	11	14	18	23	31	40	49	60
	1000	4.0	–	4.7	6.9	8.8	12	15	19	25	33	41	50
280	1800	6.4	–	7.7	11	14	19	24	32	41	54	66	81
	1500	5.4	–	6.4	9.1	12	16	20	26	34	45	55	68
	1200	4.3	–	5.2	7.3	9.4	13	16	21	27	36	44	54
	1000	3.6	–	4.3	6.1	7.9	10	13	18	23	30	37	45
315	1800	5.7	–	–	9.8	–	17	–	28	–	47	–	71
	1500	4.8	–	–	8.2	–	14	–	23	–	39	–	60
	1200	3.8	–	–	6.5	–	11	–	19	–	32	–	48
	1000	3.2	–	–	5.4	–	9.2	–	15	–	26	–	40
355	1800	5.1	–	–	8.7	–	15	–	25	–	42	–	64
	1500	4.2	–	–	7.2	–	12	–	21	–	35	–	54
	1200	3.4	–	–	5.8	–	9.7	–	16	–	28	–	43
	1000	2.8	–	–	4.8	–	8.1	–	14	–	23	–	36

Design of the gear units

Overview tables

Type B4 – Nominal output torques
Gear unit sizes 505 to 514

Technical data (continued)

Nominal output torques T_{2N} (kNm) Type B4

i_N	Gear unit sizes											Type
	504	505	506	507	508	509	510	511	512	513	514	
14	–	11.6	–	21.5	–	37	–	63.5	–	101.5	–	B3
16	7	11.6	–	21.5	–	37	–	63.5	–	101.5	–	
18	7	11.6	–	21.5	28.3	37	48.5	63.5	81	101.5	125	
20	7	11.6	16.2	21.5	28.3	37	48.5	63.5	81	101.5	125	
22.4	7	11.6	16.2	21.5	28.3	37	48.5	63.5	81	101.5	125	
25	7	11.6	16.2	21.5	28.3	37	48.5	63.5	81	101.5	125	
28	7	11.6	16.2	21.5	28.3	37	48.5	63.5	81	101.5	125	
31.5	7	11.6	16.2	21.5	28.3	37	48.5	63.5	81	101.5	125	
35.5	7	11.6	16.2	21.5	28.3	37	48.5	63.5	81	101.5	125	
40	7	11.6	16.2	21.5	28.3	37	48.5	63.5	81	101.5	125	
45	7	11.6	16.2	21.5	28.3	37	48.5	63.5	81	101.5	125	
50	7	11.6	16.2	21.5	28.3	37	48.5	63.5	81	101.5	125	
56	7	11.6	16.2	21.5	28.3	37	48.5	63.5	81	101.5	125	
63	7	11.6	16.2	21.5	28.3	37	48.5	63.5	81	101.5	125	
71	–	11.6	16.2	21.5	28.3	37	48.5	63.5	81	101.5	125	
80	–	11.6	16.2	21.5	28.3	37	48.5	63.5	81	101.5	125	
90	–	11.6	16.2	21.5	28.3	37	48.5	63.5	81	101.5	125	
100	–	11.6	16.2	21.5	28.3	37	48.5	63.5	81	101.5	125	
112	–	11.6	16.2	21.5	28.3	37	48.5	63.5	81	101.5	125	
125	–	11.6	16.2	21.5	28.3	37	48.5	63.5	81	101.5	125	
140	–	11.6	16.2	21.5	28.3	37	48.5	63.5	81	101.5	125	
160	–	11.6	16.2	21.5	28.3	37	48.5	63.5	81	101.5	125	
180	–	11.6	16.2	21.5	28.3	37	48.5	63.5	81	101.5	125	
200	–	11.6	16.2	21.5	28.3	37	48.5	63.5	81	101.5	125	
224	–	11.6	16.2	21.5	28.3	37	48.5	63.5	81	101.5	125	
250	–	11.6	16.2	21.5	28.3	37	48.5	63.5	81	101.5	125	
280	–	11.6	16.2	21.5	28.3	37	48.5	63.5	81	101.5	125	
315	–	–	16.2	–	28.3	–	48.5	–	81	–	125	
355	–	–	16.2	–	28.3	–	48.5	–	81	–	125	

3

Design of the gear units

Overview tables

Type B4 – Thermal capacities
 $n_1 = 1000 \text{ rpm}$, $n_2 = 1200 \text{ rpm}$

Technical data (continued)

Thermal capacities P_G (kW) Type B4
 $n_1 = 1000 \text{ rpm}$

i_N		Gear unit sizes									
		505	506	507	508	509	510	511	512	513	514
63	P_{GA}	28.1	–	42.7	–	60.9	–	93.9	–	124.2	–
71	P_{GA}	27.0	–	41.5	–	58.7	–	90.5	–	117.3	–
80	P_{GA}	26.5	–	40.0	46.5	57.2	65.6	87.1	100.4	114.9	132.4
90	P_{GA}	24.6	31.0	37.1	45.1	53.2	63.2	82.2	96.6	107.5	125.2
100	P_{GA}	24.2	29.8	35.8	43.4	51.9	61.7	78.8	93.0	105.3	122.5
112	P_{GA}	22.8	29.4	34.0	40.2	49.0	57.3	75.4	87.9	97.4	114.3
125	P_{GA}	22.4	27.2	32.8	38.8	47.7	55.9	72.6	84.6	95.3	111.8
140	P_{GA}	20.3	26.8	30.6	36.9	43.3	52.6	67.5	80.7	88.4	103.4
160	P_{GA}	20.0	25.2	29.6	35.6	42.3	51.2	65.1	77.6	86.6	101.3
180	P_{GA}	17.3	24.7	26.7	33.2	38.6	46.5	60.1	72.1	78.6	93.7
200	P_{GA}	17.0	22.5	25.8	32.1	37.7	45.4	58.0	69.4	77.0	91.9
224	P_{GA}	17.2	22.1	26.0	29.0	36.3	41.6	56.9	64.3	76.5	83.3
250	P_{GA}	16.6	19.2	25.3	28.1	35.5	40.6	54.2	62.0	71.9	81.7
280	P_{GA}	16.0	18.8	24.4	28.2	34.2	39.1	52.5	60.8	69.4	81.0
315	P_{GA}	–	19.1	–	27.5	–	38.2	–	57.8	–	76.1
355	P_{GA}	–	18.3	–	26.5	–	36.8	–	56.0	–	73.4

Thermal capacities P_G (kW) Type B4
 $n_1 = 1200 \text{ rpm}$

i_N		Gear unit sizes									
		505	506	507	508	509	510	511	512	513	514
63	P_{GA}	29.4	–	44.8	–	63.6	–	97.5	–	127.4	–
71	P_{GA}	28.4	–	43.4	–	61.5	–	94.0	–	120.8	–
80	P_{GA}	27.9	–	41.9	48.8	59.9	68.4	90.5	104.5	118.3	135.8
90	P_{GA}	25.9	32.7	38.9	47.3	55.9	66.1	85.9	100.7	111.1	128.8
100	P_{GA}	25.5	31.4	37.6	45.6	54.5	64.5	82.8	96.9	109.1	126.4
112	P_{GA}	24.1	30.8	35.8	42.4	51.5	60.2	79.3	91.8	101.5	118.5
125	P_{GA}	23.7	28.7	34.6	40.8	50.2	58.8	76.1	88.5	99.5	116.0
140	P_{GA}	21.4	28.2	32.3	38.9	45.6	55.5	71.1	84.8	92.5	107.9
160	P_{GA}	21.0	26.7	31.2	37.6	44.6	54.1	68.4	81.5	90.5	105.8
180	P_{GA}	18.0	26.2	27.7	35.0	40.2	49.2	62.9	76.0	81.9	98.1
200	P_{GA}	17.8	23.7	26.9	33.9	39.3	47.9	60.6	73.2	80.3	96.1
224	P_{GA}	18.1	23.3	27.1	30.1	37.9	43.3	59.5	67.1	80.0	86.9
250	P_{GA}	17.4	20.0	26.5	29.2	37.0	42.3	56.6	64.8	75.1	85.2
280	P_{GA}	16.8	19.7	25.5	29.6	35.7	40.8	54.9	63.6	72.4	84.7
315	P_{GA}	–	20.0	–	28.8	–	39.9	–	60.5	–	79.5
355	P_{GA}	–	19.2	–	27.7	–	38.5	–	58.6	–	76.7

For notes and legend for tables, see page 3/5

Design of the gear units

Overview tables

Type B4 – Thermal capacities
 $n_1 = 1500 \text{ rpm}$, $n_1 = 1800 \text{ rpm}$

Technical data (continued)

Thermal capacities P_G (kW) Type B4 $n_1 = 1500 \text{ rpm}$

i_N		Gear unit sizes									
		505	506	507	508	509	510	511	512	513	514
63	P_{GA}	31.0	–	46.9	–	66.1	–	100.2	–	128.2	–
71	P_{GA}	29.8	–	45.5	–	64.1	–	96.9	–	122.1	–
80	P_{GA}	29.3	–	43.9	51.0	62.6	71.6	93.2	107.6	120.0	137.6
90	P_{GA}	27.5	34.4	41.1	49.6	58.9	69.1	89.8	104.2	114.7	130.5
100	P_{GA}	27.0	33.1	39.7	47.9	57.5	67.4	86.5	100.4	112.0	128.0
112	P_{GA}	25.6	32.6	37.9	44.8	54.4	63.4	83.4	96.4	105.3	122.3
125	P_{GA}	25.1	30.4	36.7	43.2	53.1	62.0	80.3	92.7	103.0	119.9
140	P_{GA}	22.8	29.9	34.2	41.3	48.4	58.7	75.1	89.0	96.2	112.3
160	P_{GA}	22.4	28.3	33.1	39.9	47.3	57.3	72.2	85.8	94.4	110.0
180	P_{GA}	18.9	27.9	29.2	37.3	42.7	52.2	66.5	80.3	86.0	102.4
200	P_{GA}	18.6	25.3	28.3	36.0	41.7	50.9	64.4	77.4	84.2	100.6
224	P_{GA}	19.2	24.9	28.8	31.7	40.2	45.9	63.6	71.3	85.2	91.3
250	P_{GA}	18.4	20.9	28.0	30.7	38.9	44.8	59.9	68.7	79.3	89.6
280	P_{GA}	17.7	20.6	26.9	31.3	37.5	43.1	58.0	67.9	76.5	90.2
315	P_{GA}	–	21.2	–	30.4	–	42.0	–	63.8	–	83.9
355	P_{GA}	–	20.3	–	29.3	–	40.5	–	61.9	–	81.0

Thermal capacities P_G (kW) Type B4 $n_1 = 1800 \text{ rpm}$

i_N		Gear unit sizes									
		505	506	507	508	509	510	511	512	513	514
63	P_{GA}	31.8	–	48.1	–	67.6	–	100.8	–	126.1	–
71	P_{GA}	30.7	–	46.7	–	65.4	–	97.6	–	120.3	–
80	P_{GA}	30.2	–	45.2	52.6	63.9	73.3	94.3	108.8	118.5	136.4
90	P_{GA}	28.4	35.6	42.5	51.0	60.7	70.9	91.9	105.3	114.7	130.0
100	P_{GA}	28.0	34.3	41.1	49.3	59.4	69.3	88.5	101.7	112.6	128.0
112	P_{GA}	26.6	33.7	39.4	46.3	56.5	65.6	85.8	98.8	106.9	122.9
125	P_{GA}	26.2	31.7	38.1	44.8	55.2	64.1	82.8	95.2	104.6	120.3
140	P_{GA}	23.8	31.1	35.6	43.0	50.4	60.9	77.6	92.2	98.2	114.1
160	P_{GA}	23.5	29.6	34.5	41.5	49.3	59.5	74.9	88.6	96.3	112.0
180	P_{GA}	19.8	29.0	30.5	38.9	44.6	54.3	69.3	83.0	88.2	104.9
200	P_{GA}	19.4	26.4	29.6	37.5	43.5	53.1	66.9	80.4	86.4	102.8
224	P_{GA}	20.3	26.0	30.4	33.1	42.1	48.0	66.8	74.0	89.0	93.8
250	P_{GA}	19.3	21.9	29.6	32.1	40.9	46.9	62.9	71.6	82.9	92.0
280	P_{GA}	18.7	21.6	28.5	33.0	39.5	45.4	61.1	71.4	80.1	94.5
315	P_{GA}	–	22.4	–	32.0	–	43.9	–	67.2	–	87.9
355	P_{GA}	–	21.3	–	30.9	–	42.4	–	65.2	–	85.0

Design of the gear units

Overview tables

Types H2, H3, H4
Actual ratio, gear unit sizes 504 to 514

Technical data

Actual ratio for types H2, H3, H4

i_N	Gear unit sizes											Type
	504	505	506	507	508	509	510	511	512	513	514	
6.3	6.36	6.37	–	6.26	–	6.43	–	6.47	–	6.30	–	H2
7.1	7.18	7.04	–	6.93	–	7.10	–	7.16	–	7.00	–	
8	7.89	8.11	–	7.84	7.94	8.16	8.11	7.95	7.99	7.81	8.01	
9	8.71	8.95	8.81	8.75	8.79	9.10	8.96	8.88	8.84	8.75	8.90	
10	9.79	9.91	9.73	9.79	9.94	10.20	10.29	9.96	9.82	9.86	9.93	
11.2	10.85	11.19	11.21	11.32	11.11	11.58	11.48	11.25	10.96	11.20	11.12	
12.5	12.64	12.53	12.37	12.66	12.43	13.13	12.87	12.95	12.30	12.60	12.54	
14	14.08	14.32	13.71	14.29	14.35	14.62	14.62	14.50	13.89	14.39	14.24	
16	15.80	16.11	15.46	16.04	16.06	16.25	16.56	15.93	16.00	16.33	16.02	
18	17.86	18.10	17.31	17.26	18.12	18.25	18.45	18.09	17.92	17.50	18.29	
20	19.94	20.49	19.78	20.57	20.36	20.64	20.50	19.96	19.67	19.95	20.77	
22.4	–	22.97	22.25	23.02	21.90	23.39	23.03	22.98	22.35	22.45	22.25	H3
25	–	26.24	25.00	25.97	26.11	26.06	26.03	25.73	24.65	25.63	25.37	
28	–	28.36	28.32	27.96	29.21	29.77	29.50	28.79	28.39	28.46	28.54	
31.5	–	32.40	31.76	31.52	32.95	33.15	32.86	32.23	31.79	32.51	32.59	
35.5	–	34.73	36.24	34.85	35.46	36.35	37.54	35.98	35.56	35.61	36.19	
40	–	39.59	39.23	39.31	39.97	40.48	41.81	40.29	39.82	40.67	41.34	
45	–	43.77	44.88	45.17	44.15	45.96	45.88	46.52	44.46	45.82	45.27	
50	–	50.00	47.93	50.95	49.82	51.18	51.11	52.09	49.75	52.32	51.70	
56	–	57.14	54.73	57.18	57.29	58.45	57.95	58.74	57.45	58.27	58.25	
63	–	63.39	60.67	63.99	64.61	66.43	64.58	63.37	64.34	63.72	66.52	
71	–	72.50	69.23	72.15	72.38	74.00	73.82	71.03	72.58	72.76	74.10	
80	–	–	79.02	81.44	81.09	83.71	83.77	84.55	78.34	82.25	81.01	H4
90	–	–	87.57	91.49	91.59	93.91	93.27	94.63	87.66	93.20	92.46	
100	–	–	100.00	101.90	103.28	107.25	105.66	106.72	104.52	103.78	104.52	
112	–	–	–	114.36	115.98	115.99	118.29	114.83	117.05	118.57	118.48	
125	–	–	–	125.00	129.22	132.62	135.10	129.59	131.92	132.16	132.00	
140	–	–	–	140.52	145.13	141.76	146.53	143.34	141.86	144.79	150.78	
160	–	–	–	156.93	158.99	162.28	167.24	161.58	160.08	161.37	168.01	
180	–	–	–	176.23	177.99	178.74	178.97	185.67	176.86	183.21	184.09	
200	–	–	–	202.83	199.30	204.42	204.64	209.57	199.51	203.82	205.25	
224	–	–	–	231.18	224.60	234.18	225.58	235.19	229.46	233.33	232.77	
250	–	–	–	259.04	257.27	258.74	257.98	263.49	258.79	264.32	259.34	
280	–	–	–	294.52	291.75	296.00	295.73	296.73	290.32	294.20	296.21	
315	–	–	–	–	329.07	333.33	325.50	332.46	325.30	327.42	336.02	
355	–	–	–	–	372.37	–	373.08	–	366.52	–	374.25	
400	–	–	–	–	–	–	418.10	–	411.17	–	416.67	

Design of the gear units

Overview tables

Types B3, B4
Actual ratio, gear unit sizes 504 to 514

Technical data (continued)

Actual ratio for types B3, B4

i_N	Gear unit sizes											Type
	504	505	506	507	508	509	510	511	512	513	514	
14	–	13.96	–	13.80	–	14.20	–	13.86	–	13.72	–	B3
16	15.28	15.76	–	15.94	–	16.12	–	15.65	–	15.58	–	
18	17.81	17.66	–	17.84	17.51	18.27	17.91	18.02	17.12	17.53	17.45	
20	19.83	20.17	19.31	20.13	20.23	20.35	20.34	20.18	19.33	20.02	19.81	
22.4	22.22	22.44	21.77	22.66	22.64	23.49	23.05	23.18	22.26	22.55	22.29	
25	25.18	25.61	24.40	25.56	25.54	26.17	25.67	25.95	24.93	25.75	25.45	
28	28.23	28.02	27.88	28.29	28.76	29.55	29.65	29.95	28.63	28.16	28.67	
31.5	31.39	31.96	30.98	31.95	32.42	32.92	33.02	33.54	32.07	32.16	32.74	
35.5	35.35	34.73	35.45	35.07	35.91	36.35	37.28	35.88	37.00	34.89	35.81	
40	38.89	39.59	38.66	39.52	40.49	40.48	41.52	40.16	41.43	39.85	40.89	
45	43.75	44.44	44.26	44.89	44.50	46.54	45.88	45.91	44.31	44.67	44.36	
50	50.00	50.66	47.93	50.59	50.18	51.82	51.11	51.42	49.60	51.01	50.67	
56	56.00	56.04	54.73	55.84	56.94	57.19	58.72	56.70	56.72	56.23	56.79	
63	61.95	63.04	61.36	64.37	64.17	64.35	65.45	65.60	63.53	64.24	64.87	
71	–	70.73	70.13	71.67	70.75	72.12	72.17	73.41	70.01	72.81	71.51	
80	–	80.56	77.51	80.52	81.79	82.41	81.24	82.79	81.00	81.07	81.65	
90	–	89.92	87.10	91.10	91.00	91.58	90.99	93.25	90.71	93.63	92.52	
100	–	102.65	97.59	102.38	102.17	104.82	104.08	105.13	102.27	104.32	103.05	
112	–	111.54	111.72	113.76	115.51	114.55	115.48	116.51	115.06	117.75	119.05	
125	–	127.47	123.66	127.98	129.82	130.74	132.15	131.20	129.81	131.14	132.56	
140	–	138.10	142.11	141.45	144.39	141.76	144.35	144.32	143.87	144.79	149.70	
160	–	158.90	154.29	158.09	161.71	162.28	164.97	162.82	162.32	161.37	166.67	
180	–	178.46	176.09	180.67	179.11	181.37	178.97	184.59	178.02	185.56	184.09	
200	–	203.51	192.86	202.83	200.71	207.87	204.64	208.20	200.99	206.72	205.25	
224	–	223.08	218.92	223.96	228.23	228.40	228.77	229.24	228.17	227.58	235.85	
250	–	257.78	245.45	255.95	257.27	260.56	262.16	261.32	257.14	259.59	262.61	
280	–	282.93	279.31	286.67	283.00	293.65	288.69	293.98	283.22	288.35	289.35	
315	–	–	311.54	–	321.59	–	327.70	–	322.71	–	329.82	
355	–	–	352.17	–	367.53	–	370.23	–	363.23	–	366.57	
												B4

Design of the gear units

Overview tables

Notes

3

Helical gear units horizontal mounting position

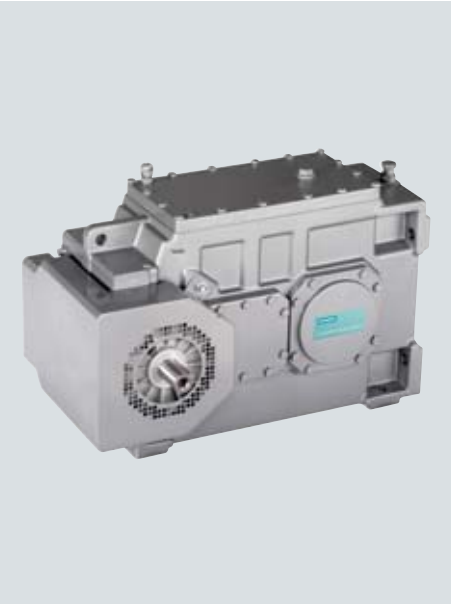

4/2	Type H2 <u>Gear unit dimensions</u> Two-stage, gear unit sizes 504 to 508 Two-stage, gear unit sizes 509 to 514
4/6	Type H3 <u>Gear unit dimensions</u> Three-stage, gear unit sizes 505 to 508 Three-stage, gear unit sizes 509 to 514
4/10	Type H4 <u>Gear unit dimensions</u> Four-stage, gear unit sizes 507 to 508 Four-stage, gear unit sizes 509 to 514
4/14	Types H2, H3 and H4 Order number overview

Helical gear units horizontal mounting position

Type H2

Gear unit dimensions
Two-stage, gear unit sizes 504 to 508

Selection and ordering data

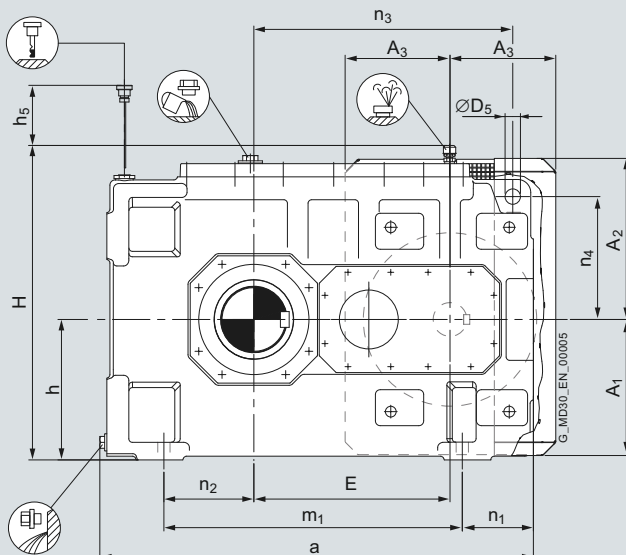
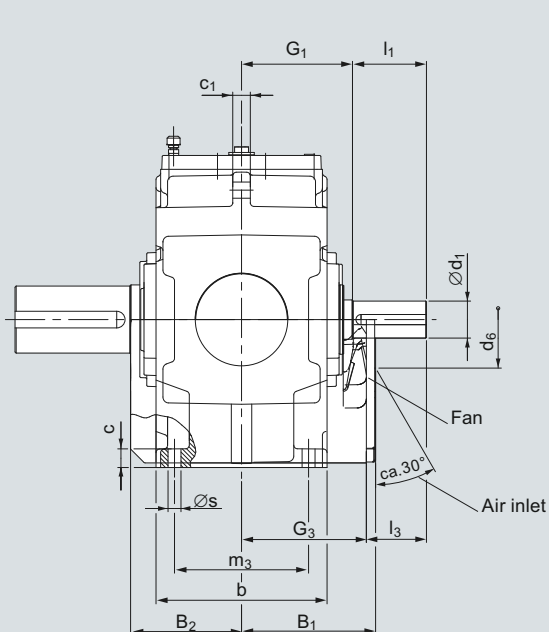

Gear unit sizes	Dimensions in mm										Fan								
	Input																		
	d_1	l_1	l_3	d_1	l_1	l_3	d_1	l_1	l_3	G_1	G_3	A_1	A_2	A_3	A_4	B_1	B_2	d_6	
504	$i_N = 6.3 - 11.2$ 45 m6	100	80	12.5 - 16	35 m6	80	60	28 m6	70	50	170	190	195	240	170	160	235	175	150
505	$i_N = 6.3 - 10$ 60 m6	125	105	11.2 - 14	45 m6	100	80	32 m6	80	60	195	215	225	275	200	175	255	180	160
506	$i_N = 9 - 14$ 60 m6	125	105	16 - 20	45 m6	100	80	32 m6	80	60	195	215	225	275	200	175	255	180	160
507	$i_N = 6.3 - 10$ 70 m6	135	105	11.2 - 18	50 m6	110	80				210	240	275	330	235	210	280	205	190
508	$i_N = 8 - 12.5$ 70 m6	135	105	14 - 22.4	50 m6	110	80				210	240	275	330	235	210	280	205	190

Gear unit sizes	Dimensions in mm																Backstop ¹⁾	
	Gear units																	
	a	b	c	c_1	D_5	E	H	h	h_5	m_1	m_3	n_1	n_2	n_3	n_4	s	D_B	G_B
504	604	210	28	18	19	269.5	440	200	340	415	170	95	130	355	175	19	140	205
505	684	250	30	27	24	310	510	230	380	490	200	95	145	405	202	19	175	254
506	807	250	30	27	24	363	510	230	380	613	200	95	215	458	202	19	175	254
507	855	295	35	30	28	384	610	280	430	595	230	129	180	505	250	24	190	320
508	962	295	35	30	28	431	610	280	430	702	230	129	240	552	250	24	190	320

Note: Remove air guide cover before fitting the foundation bolts.
Note: Refer to pages 6/2 to 6/5 for shaft details.

Helical gear units horizontal mounting position

Type H2

Gear unit dimensions
Two-stage, gear unit sizes 504 to 508

Selection and ordering data (continued)

Output

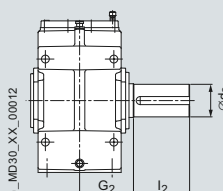
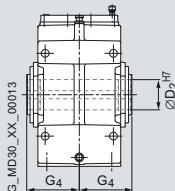
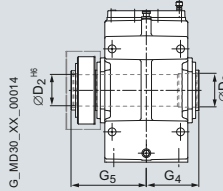
				Oil quantity 2)	Weight 2) 3)	For order no. supplement for 7th and 11th to 16th position, see pages 4/14 to 4/16		
Order No.:		2LP202 - ■ - ■ L ■ - ■ ■ ■ ■						
Solid shaft								
Type	Size	d ₂	l ₂	G ₂	l	kg		
H2SH	504	80 m6	170	140	12	109	3 A	
	505	100 m6	210	165	18	285	4 A	
	506	110 n6	210	165	19	360	5 A	
	507	120 n6	210	195	32	505	6 A	
	508	130 n6	250	195	35	600	7 A	
								
Hollow shaft with keyway								
Type	Size	D ₂	G ₄		l	kg		
H2HH	504	80 H7	140		12	109	3 D	
	505	95 H7	165		18	285	4 D	
	506	105 H7	165		19	360	5 D	
	507	115 H7	195		32	505	6 D	
	508	125 H7	195		35	600	7 D	
								
Hollow shaft for shrink disk								
Type	Size	D ₂	D ₃	G ₄	G ₅	l	kg	
H2DH	504	85 H6	85	140	215	12	109	3 G
	505	100 H6	100	165	255	18	285	4 G
	506	110 H6	110	165	260	19	360	5 G
	507	120 H6	120	195	290	32	505	6 G
	508	130 H6	130	195	305	35	600	7 G
								

4

Design

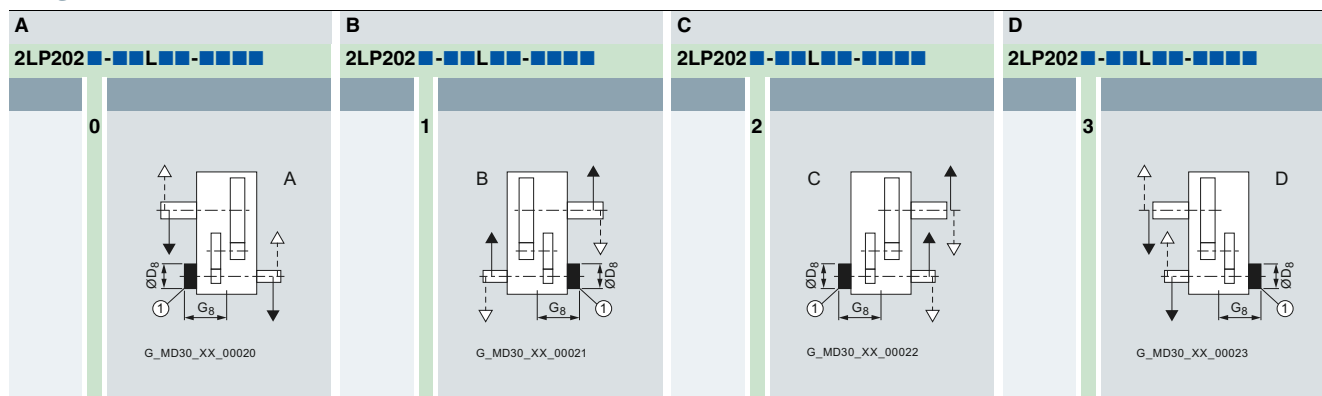

① Backstop

1) Max. dimensions; details acc. to order-related documentation.

2) Approximate values; exact data acc. to order-related documentation.

3) Without oil filling

Helical gear units horizontal mounting position

Type H2

Gear unit dimensions
Two-stage, gear unit sizes 509 to 514

Selection and ordering data

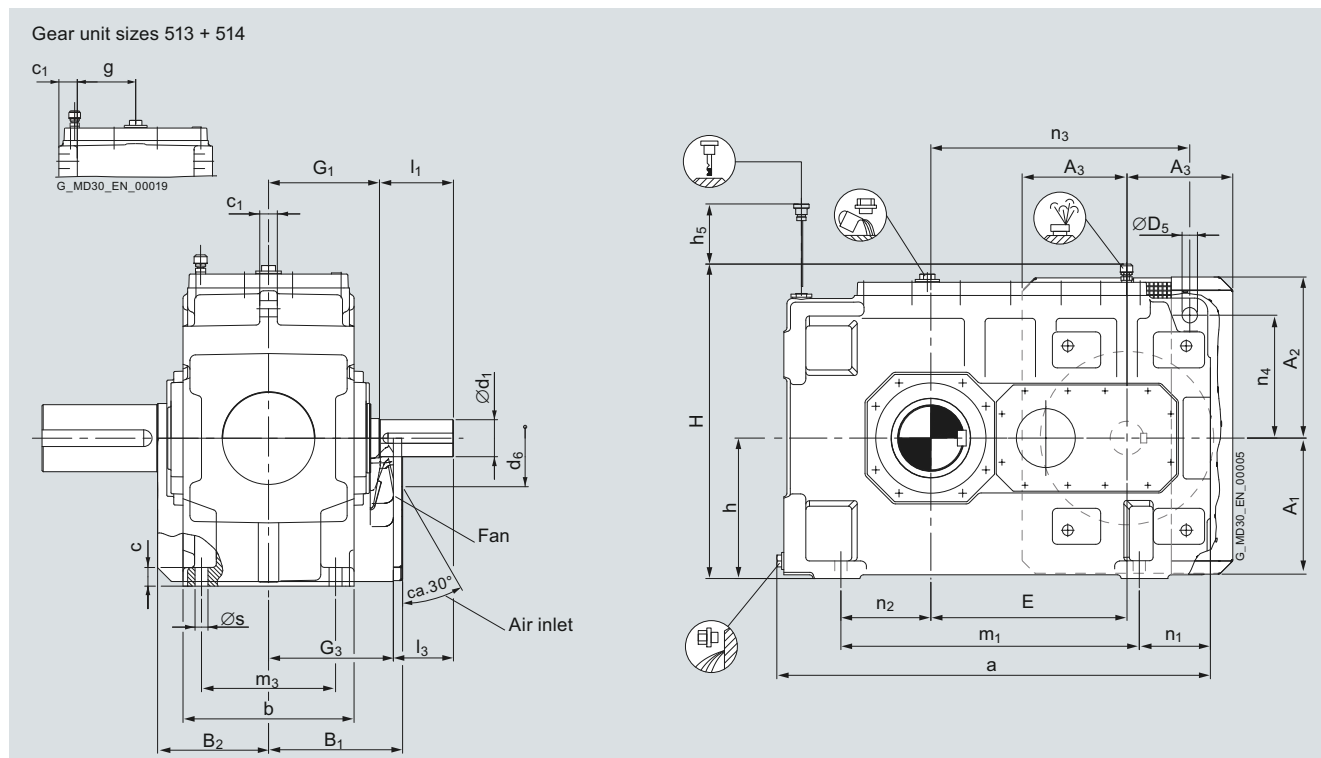

Gear unit sizes	Dimensions in mm																		
	Input									Fan									
	d ₁	l ₁	l ₃	d ₁	l ₁	l ₃	d ₁	l ₁	l ₃	G ₁	G ₃	A ₁	A ₂	A ₃	A ₄	B ₁	B ₂	d ₆	
509	$i_N = 6.3 - 10$	6.3 - 10	160	130	11.2 - 14	140	110	16 - 20	110	80	240	270	315	370	265	240	310	245	175
		80 m6	160	130	60 m6	140	110	50 m6	110	80	240	270	315	370	265	240	310	245	175
510	$i_N = 8 - 12.5$	8 - 12.5	160	130	14 - 18	140	110	20 - 22.4	110	80	240	270	315	370	265	240	310	245	175
		80 m6	160	130	60 m6	140	110	50 m6	110	80	240	270	315	370	265	240	310	245	175
511	$i_N = 6.3 - 10$	6.3 - 10	180	145	11.2 - 14	165	130	16 - 20	140	105	275	310	370	430	315	295	355	285	190
		100 m6	180	145	80 m6	165	130	70 m6	140	105	275	310	370	430	315	295	355	285	190
512	$i_N = 8 - 12.5$	8 - 12.5	180	145	14 - 18	165	130	20 - 22.4	140	105	275	310	370	430	315	295	355	285	190
		100 m6	180	145	80 m6	165	130	70 m6	140	105	275	310	370	430	315	295	355	285	190
513	$i_N = 6.3 - 10$	6.3 - 10	200	165	11.2 - 14	165	130	16 - 20	140	105	330	365	430	460	355	330	385	350	225
		110 n6	200	165	90 m6	165	130	75 m6	140	105	330	365	430	460	355	330	385	350	225
514	$i_N = 8 - 12.5$	8 - 12.5	200	165	14 - 18	165	130	20 - 22.4	140	105	330	365	430	460	355	330	385	350	225
		110 n6	200	165	90 m6	165	130	75 m6	140	105	330	365	430	460	355	330	385	350	225

Gear unit sizes	Dimensions in mm																		
	Gear units																		Backstop ¹⁾
	a	b	c	c ₁	D ₅	E	g	H	h	h ₅	m ₁	m ₃	n ₁	n ₂	n ₃	n ₄	s	D ₃	G ₃
509	988	370	40	38	35	447	-	695	320	475	680	290	162	205	590	280	28	230	355
510	1106	370	40	38	35	500	-	695	320	475	798	290	162	270	643	280	28	230	355
511	1204	430	50	43	40	547	-	820	380	540	825	340	202	255	713	328	35	230	389
512	1332	430	50	43	40	605	-	820	380	540	953	340	202	325	771	328	35	230	389
513	1345	535	60	65	48	640	202.5	940	440	600	920	445	245	260	842	380	42	270	455
514	1463	535	60	65	48	718	202.5	940	440	600	1038	445	245	300	920	380	42	270	455

Note: Remove air guide cover before fitting the foundation bolts.
Note: Refer to pages 6/2 to 6/5 for shaft details.

Helical gear units horizontal mounting position

Type H2

Gear unit dimensions
Two-stage, gear unit sizes 509 to 514

Selection and ordering data (continued)

Output

				Oil quantity 2)		Weight 2) 3)		For order no. supplement for 7th and 11th to 16th position, see pages 4/14 to 4/16	
Order No.: 2LP202 - - - L - - - - -									
Type	Size	d_2	l_2	G_2	l	kg		Solid shaft	
H2SH	509	145 n6	250	240	52	830	8 A		
	510	160 n6	300	240	55	945	0 B		
	511	175 n6	300	270	84	1365	1 B		
	512	185 n6	350	270	89	1570	2 B		
	513	200 n6	350	330	150	2600	3 B		
	514	210 n6	350	330	155	2965	4 B		
Type	Size	D_2		G_4	l	kg		Hollow shaft with keyway	
H2HH	509	135 H7		235	52	830	8 D		
	510	150 H7		235	55	945	0 E		
	511	165 H7		270	84	1365	1 E		
	512	180 H7		270	89	1570	2 E		
	513	190 H7		330	150	2600	3 E		
	514	210 H7		330	155	2965	4 E		
Type	Size	D_2	D_3	G_4	G_5	l	kg		Hollow shaft for shrink disk
H2DH	509	140 H6	145	235	350	52	830	8 G	
	510	150 H6	155	235	370	55	945	0 H	
	511	165 H6	170	270	420	84	1365	1 H	
	512	180 H6	185	270	425	89	1570	2 H	
	513	190 H6	195	330	495	150	2600	3 H	
	514	210 H6	215	330	495	155	2965	4 H	

4

Design

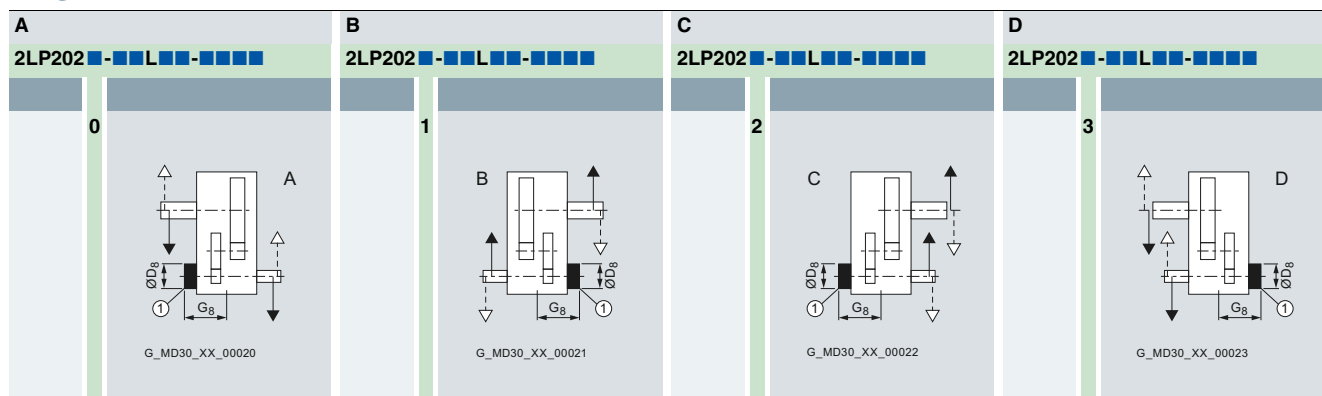

① Backstop

1) Max. dimensions; details acc. to order-related documentation.

2) Approximate values; exact data acc. to order-related documentation.

3) Without oil filling

Helical gear units horizontal mounting position

Type H3

Gear unit dimensions
Three-stage, gear unit sizes 505 to 508

Selection and ordering data

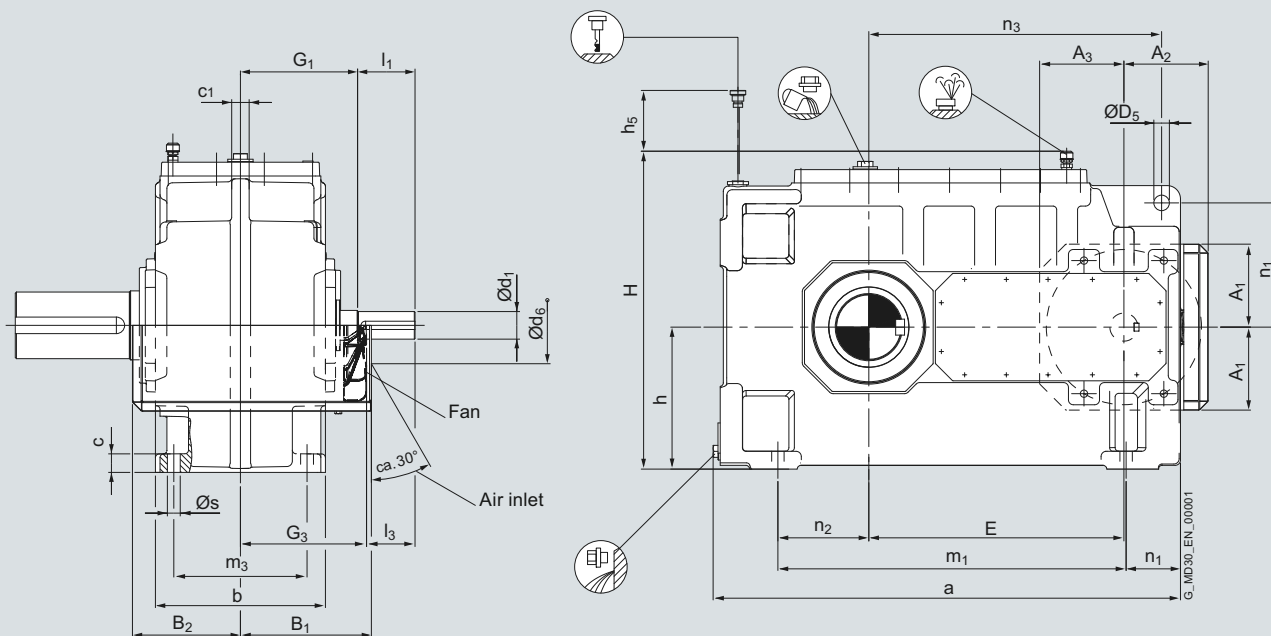

Gear unit sizes	Dimensions in mm																
	Input									Fan							
	d ₁	l ₁	l ₃	d ₁	l ₁	l ₃	d ₁	l ₁	l ₃	G ₁	G ₃	A ₁	A ₂	A ₃	B ₁	B ₂	d ₆
505	$i_N = 20 - 40$	45 - 56			63 - 71												
	40 m6 90	70	30 m6 70	50	24 k6 60	40	180	200	145	150	140	210	175	135			
506	$i_N = 28 - 56$	63 - 80			90 - 100												
	40 m6 90	70	30 m6 70	50	24 k6 60	40	180	200	145	150	140	210	175	135			
507	$i_N = 20 - 40$	45 - 56			63 - 71												
	45 m6 100	80	35 m6 80	60	28 m6 70	50	210	230	170	190	190	245	205	150			
508	$i_N = 25 - 50$	56 - 71			80 - 90												
	45 m6 100	80	35 m6 80	60	28 m6 70	50	210	230	170	190	190	245	205	150			

Gear unit sizes	Dimensions in mm																	
	Gear units																Backstop ¹⁾	
	a	b	c	c ₁	D ₅	E	H	h	h ₅	m ₁	m ₃	n ₁	n ₂	n ₃	n ₄	s	D ₈	G ₃
505	727	250	30	27	24	400	510	230	380	530	200	97.5	145	455	202	19	150	225
506	850	250	30	27	24	453	510	230	380	653	200	97.5	215	508	202	19	150	225
507	912	295	35	30	28	493.5	610	280	430	680	230	101	180	570	250	24	175	290
508	1019	295	35	30	28	540.5	610	280	430	787	230	101	240	617	250	24	175	290

Note: Refer to pages 6/2 to 6/5 for shaft details.

Helical gear units horizontal mounting position

Type H3

Gear unit dimensions
Three-stage, gear unit sizes 505 to 508

Selection and ordering data (continued)

Output

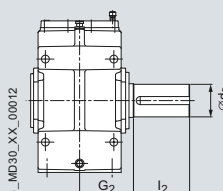
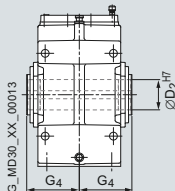
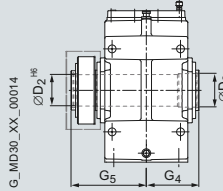
				Oil quantity 2)		Weight 2) 3)		For order no. supplement for 7th and 11th to 16th position, see pages 4/14 to 4/16	
Order No.:		2LP202 - ■ - ■ M ■ - ■ ■ ■ ■							
Type	Size	d_2	l_2	G_2	l	kg		Solid shaft	
H3SH	505	100 m6	210	165	20	310	4 A		
	506	110 n6	210	165	21	380	5 A		
	507	120 n6	210	195	34	535	6 A		
	508	130 n6	250	195	37	630	7 A		
Type	Size	D_2		G_4	l	kg		Hollow shaft with keyway	
H3HH	505	95 H7		165	20	310	4 D		
	506	105 H7		165	21	380	5 D		
	507	115 H7		195	34	535	6 D		
	508	125 H7		195	37	630	7 D		
Type	Size	D_2	D_3	G_4	G_5	l	kg		Hollow shaft for shrink disk
H3DH	505	100 H6	100	165	255	20	310	4 G	
	506	110 H6	110	165	260	21	380	5 G	
	507	120 H6	120	195	290	34	535	6 G	
	508	130 H6	130	195	305	37	630	7 G	

4

Design

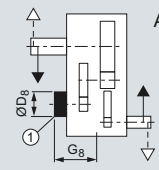
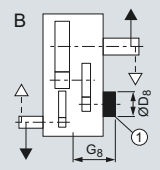
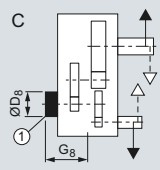
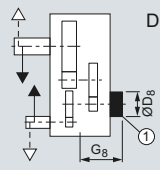
A	B	C	D
2LP202 - ■ - ■ M ■ - ■ ■ ■ ■	2LP202 - ■ - ■ M ■ - ■ ■ ■ ■	2LP202 - ■ - ■ M ■ - ■ ■ ■ ■	2LP202 - ■ - ■ M ■ - ■ ■ ■ ■
<p>0</p>  <p>G_MD30_XX_00024</p>	<p>1</p>  <p>G_MD30_XX_00025</p>	<p>2</p>  <p>G_MD30_XX_00026</p>	<p>3</p>  <p>G_MD30_XX_00027</p>

① Backstop

1) Max. dimensions; details acc. to order-related documentation.

2) Approximate values; exact data acc. to order-related documentation.

3) Without oil filling

Helical gear units horizontal mounting position

Type H3

Gear unit dimensions
Three-stage, gear unit sizes 509 to 514

Selection and ordering data

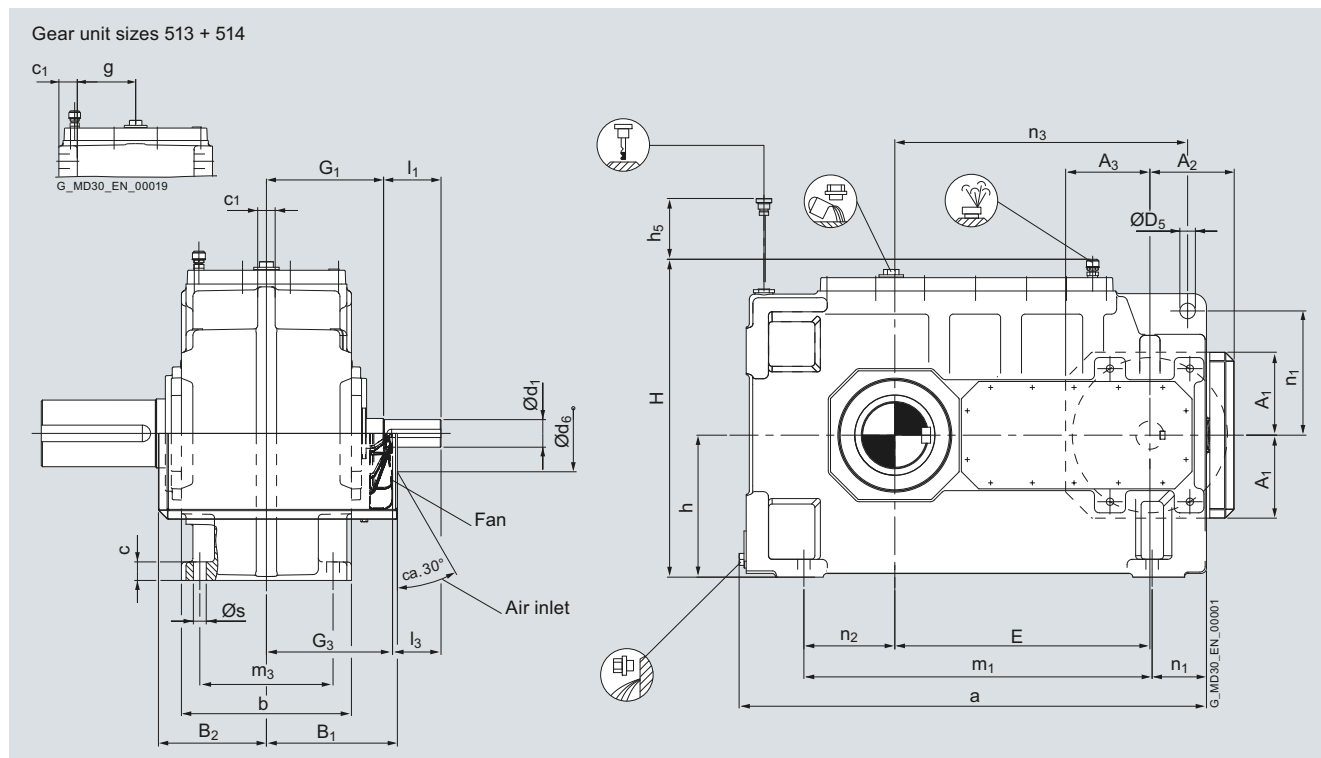

Gear unit sizes	Dimensions in mm																
	Input									Fan							
	d_1	l_1	l_3	d_1	l_1	l_3	d_1	l_1	l_3	G_1	G_3	A_1	A_2	A_3	B_1	B_2	d_6
$i_N =$	20 – 40			45 – 56			63 – 71										
509	60 m6	125	105	45 m6	100	80	32 m6	80	60	255	275	195	215	190	285	235	160
$i_N =$	25 – 50			56 – 71			80 – 90										
510	60 m6	125	105	45 m6	100	80	32 m6	80	60	255	275	195	215	190	285	235	160
$i_N =$	20 – 40			45 – 56			63 – 71										
511	70 m6	135	105	50 m6	110	80	48 m6	110	80	275	305	225	245	225	320	270	190
$i_N =$	25 – 50			56 – 71			80 – 90										
512	70 m6	135	105	50 m6	110	80	48 m6	110	80	275	305	225	245	225	320	270	190
$i_N =$	20 – 40			45 – 56			63 – 71										
513	85 m6	160	130	65 m6	140	110	50 m6	110	80	320	350	225	250	225	370	340	175
$i_N =$	25 – 50			56 – 71			80 – 90										
514	85 m6	160	130	65 m6	140	110	50 m6	110	80	320	350	225	250	225	370	340	175

Gear unit sizes	Dimensions in mm																		
	Gear units																	Backstop ¹⁾	
	a	b	c	c_1	D_5	E	g	H	h	h_5	m_1	m_3	n_1	n_2	n_3	n_4	s	D_8	G_8
509	1054	370	40	38	35	575	–	695	320	475	785	290	122.5	205	660	280	28	190	335
510	1172	370	40	38	35	628	–	695	320	475	903	290	122.5	270	713	280	28	190	335
511	1296	430	50	43	40	706	–	820	380	540	960	340	158.5	255	805	320	35	230	370
512	1424	430	50	43	40	764	–	820	380	540	1088	340	158.5	325	863	320	35	230	370
513	1452	535	60	65	48	825	202.5	940	440	600	1092	445	180	260	952	380	42	255	430
514	1570	535	60	65	48	903	202.5	940	440	600	1210	445	180	300	1030	380	42	255	430

Note: Refer to pages 6/2 to 6/5 for shaft details.

Helical gear units horizontal mounting position

Type H3

Gear unit dimensions
Three-stage, gear unit sizes 509 to 514

Selection and ordering data (continued)

Output

				Oil quantity 2)	Weight 2) 3)	For order no. supplement for 7th and 11th to 16th position, see pages 4/14 to 4/16		
Order No.:		2LP202 - ■ - ■ M ■ - ■ ■ ■ ■						
Type	Size	d ₂	l ₂	G ₂	l	kg	Solid shaft	
H3SH	509	145 n6	250	240	58	875	8 A	
	510	160 n6	300	240	59	1025	0 B	
	511	175 n6	300	270	98	1460	1 B	
	512	185 n6	350	270	103	1670	2 B	
	513	200 n6	350	330	175	2510	3 B	
	514	210 n6	350	330	180	2860	4 B	
Type	Size	D ₂	G ₄		l	kg	Hollow shaft with keyway	
H3HH	509	135 H7	235		58	875	8 D	
	510	150 H7	235		59	1025	0 E	
	511	165 H7	270		98	1460	1 E	
	512	180 H7	270		103	1670	2 E	
	513	190 H7	330		175	2510	3 E	
	514	210 H7	330		180	2860	4 E	
Type	Size	D ₂	D ₃	G ₄	G ₅	l	kg	
H3DH	509	140 H6	145	235	350	58	875	8 G
	510	150 H6	155	235	370	59	1025	0 H
	511	165 H6	170	270	420	98	1460	1 H
	512	180 H6	185	270	425	103	1670	2 H
	513	190 H6	195	330	495	175	2510	3 H
	514	210 H6	215	330	495	180	2860	4 H

4

Design

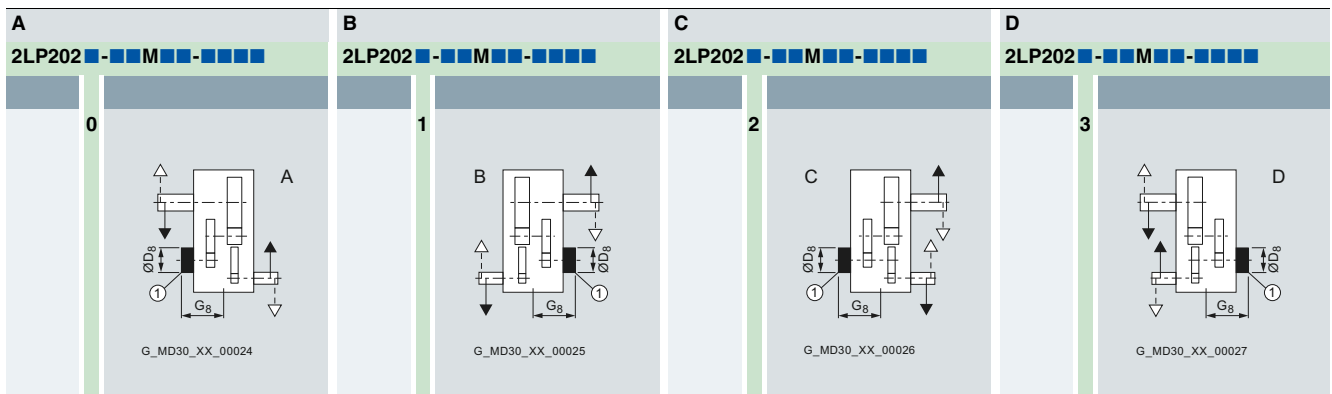

① Backstop

1) Max. dimensions; details acc. to order-related documentation.

2) Approximate values; exact data acc. to order-related documentation.

3) Without oil filling

Helical gear units horizontal mounting position

Type H4

Gear unit dimensions
Four-stage, gear unit sizes 507 to 508

Selection and ordering data

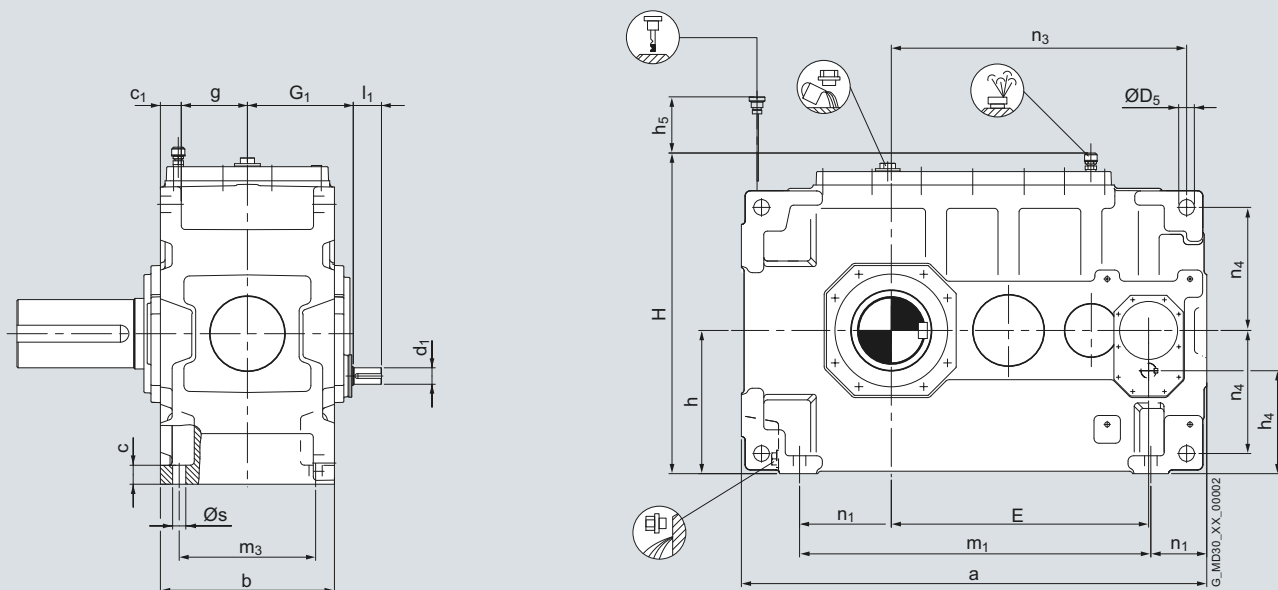

Gear unit sizes	Dimensions in mm				
	Input				
	d_1	l_1	d_1	l_1	G_1
507	$i_N = 80 - 140$ 35 m6 60	160 - 280 28 m6 50			215
508	$i_N = 100 - 180$ 35 m6 60	200 - 355 28 m6 50			215

Gear unit sizes	Dimensions in mm																			Backstop¹⁾
	Gear units																			
	a	b	c	c_1	D_5	E	g	H	h	h_4	h_5	m_1	m_3	n_1	n_2	n_3	n_4	s	D_8	G_8
507	899	295	35	35	28 H9	493.5	112.5	610	280	198	430	680	230	104	180	567.5	242.5	24	102	245
508	1006	295	35	35	28 H9	540.5	112.5	610	280	198	430	787	230	104	240	614.5	242.5	24	102	245

Note: Refer to pages 6/2 to 6/5 for shaft details.

Helical gear units horizontal mounting position

Type H4

Gear unit dimensions
Four-stage, gear unit sizes 507 to 508

Selection and ordering data (continued)

Output

				Oil quantity 2)	Weight 2) 3)	For order no. supplement for 7th and 11th to 16th position, see pages 4/14 to 4/16	
Order No.:		2LP202 - ■ - ■ N ■ - ■ ■ ■ ■					
Solid shaft							
Type	Size	d_2	l_2	G_2	l	kg	
H4SH	507	120 n6	210	195	30	520	6 A
	508	130 n6	250	195	32	615	7 A
Hollow shaft with keyway							
Type	Size	D_2	G_4	l	kg		
H4HH	507	115 H7	195	30	520	6 D	
	508	125 H7	195	32	615	7 D	
Hollow shaft for shrink disk							
Type	Size	D_2	D_3	G_4	G_5	l	kg
H4DH	507	120 H6	120	195	290	30	520
	508	130 H6	130	195	305	32	615

4

Design

A	B	C	D
2LP202 - ■ - ■ N ■ - ■ ■ ■ ■	2LP202 - ■ - ■ N ■ - ■ ■ ■ ■	2LP202 - ■ - ■ N ■ - ■ ■ ■ ■	2LP202 - ■ - ■ N ■ - ■ ■ ■ ■
0	1	2	3

① Backstop

- 1) Max. dimensions; details acc. to order-related documentation.
- 2) Approximate values; exact data acc. to order-related documentation.
- 3) Without oil filling

Helical gear units horizontal mounting position

Type H4

Gear unit dimensions
Four-stage, gear unit sizes 509 to 514

Selection and ordering data

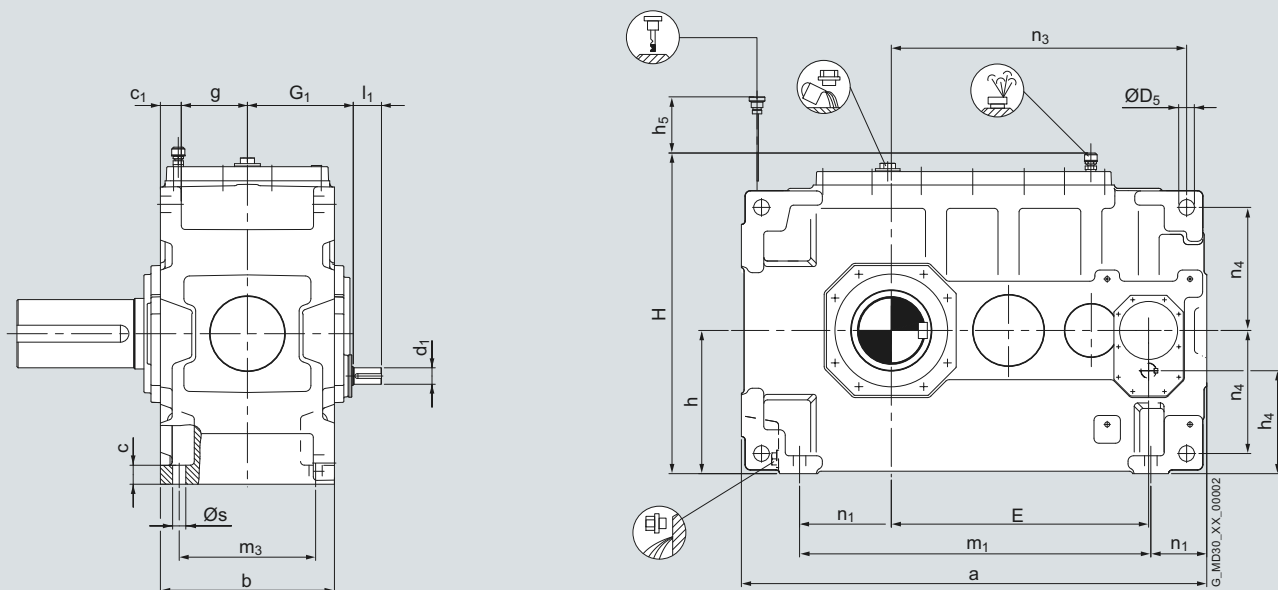

Gear unit sizes	Dimensions in mm						
	Input						
	d_1	l_1	d_1	l_1	d_1	l_1	G_1
509	$i_N = 80 - 160$ 35 m6 60	180 - 315 28 m6 50					225
510	$i_N = 100 - 200$ 35 m6 60	224 - 400 28 m6 50					225
511	$i_N = 80 - 160$ 45 m6 100	180 - 224 35 m6 80	250 - 315 27 m6 70				255
512	$i_N = 100 - 200$ 45 m6 100	224 - 280 35 m6 80	315 - 400 27 m6 70				255
513	$i_N = 80 - 160$ 60 m6 125	180 - 224 45 m6 100	250 - 315 32 m6 80				305
514	$i_N = 100 - 200$ 60 m6 125	224 - 280 45 m6 100	315 - 400 32 m6 80				305

Gear unit sizes	Dimensions in mm																		Backstop¹⁾	
	Gear units																			
	a	b	c	c_1	D_5	E	g	H	h	h_4	h_5	m_1	m_3	n_1	n_2	n_3	n_4	s	D_8	G_8
509	1040	370	40	45	35	575	140	695	320	230	475	785	290	125	205	458	275	28	125	285
510	1158	370	40	45	35	628	140	695	320	230	475	903	290	125	270	713	275	28	125	285
511	1281	430	50	60	40	706	155	820	380	270.5	540	960	340	161	255	8125	330	35	150	335
512	1409	430	50	60	40	764	155	820	380	270.5	540	1088	340	161	325	8705	330	35	150	335
513	1455	535	60	65	48	825	202.5	940	440	312	600	1092	445	183	260	952	380	42	175	405
514	1573	535	60	65	48	903	202.5	940	440	312	600	1210	445	183	300	1030	380	42	175	405

Note: Refer to pages 6/2 to 6/5 for shaft details.

Helical gear units horizontal mounting position

Type H4

Gear unit dimensions
Four-stage, gear unit sizes 509 to 514

Selection and ordering data (continued)

Output

						Oil quantity 2)	Weight 2) 3)	For order no. supplement for 7th and 11th to 16th position, see pages 4/14 to 4/16	
Order No.:		2LP202 - ■ - ■ N ■ - ■ ■ ■ ■							
Type	Size	d ₂	l ₂	G ₂	l	kg		Solid shaft	
H4SH	509	145 n6	250	240	58	820	8 A		
	510	160 n6	300	240	60	980	0 B		
	511	175 n6	300	270	93	1410	1 B		
	512	185 n6	350	270	100	1620	2 B		
	513	200 n6	350	330	145	2375	3 B		
	514	210 n6	350	330	155	2690	4 B		
Type	Size	D ₂		G ₄	l	kg		Hollow shaft with keyway	
H4HH	509	135 H7		235	58	820	8 D		
	510	150 H7		235	60	980	0 E		
	511	165 H7		270	93	1410	1 E		
	512	180 H7		270	100	1620	2 E		
	513	190 H7		330	145	2375	3 E		
	514	210 H7		330	155	2690	4 E		
Type	Size	D ₂	D ₃	G ₄	G ₅	l	kg		Hollow shaft for shrink disk
H4DH	509	140 H6	145	235	350	58	820	8 G	
	510	150 H6	155	235	370	60	980	0 H	
	511	165 H6	170	270	420	93	1410	1 H	
	512	180 H6	185	270	425	100	1620	2 H	
	513	190 H6	195	330	495	145	2375	3 H	
	514	210 H6	215	330	495	155	2690	4 H	

4

Design

A	B	C	D
2LP202 - ■ - ■ N ■ - ■ ■ ■ ■	2LP202 - ■ - ■ N ■ - ■ ■ ■ ■	2LP202 - ■ - ■ N ■ - ■ ■ ■ ■	2LP202 - ■ - ■ N ■ - ■ ■ ■ ■
0	1	2	3

① Backstop

1) Max. dimensions; details acc. to order-related documentation.
 2) Approximate values; exact data acc. to order-related documentation.
 3) Without oil filling

Helical gear units horizontal mounting position

Types H2, H3 and H4

Order number overview

Selection and ordering data

Order no. supplement 7th position

Position	1 to 6	7	8	9	10	11	12	13	14	15	16
Order number	2LP202 -										

Design

Type	H2.H	H3.H	H4.H
------	------	------	------

A

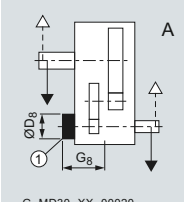
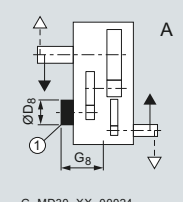
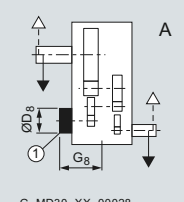
		
G_MD30_XX_00020	G_MD30_XX_00024	G_MD30_XX_00028

B

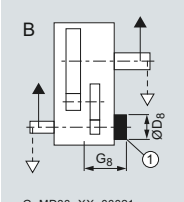
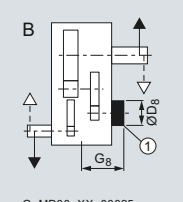
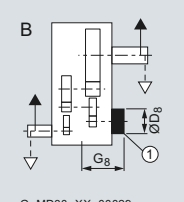
		
G_MD30_XX_00021	G_MD30_XX_00025	G_MD30_XX_00029

C

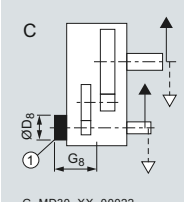
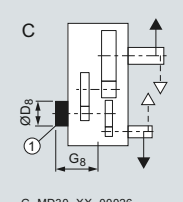
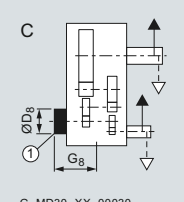
		
G_MD30_XX_00022	G_MD30_XX_00026	G_MD30_XX_00030

D

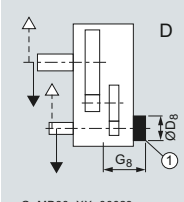
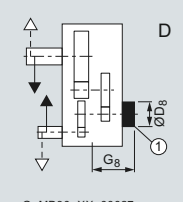
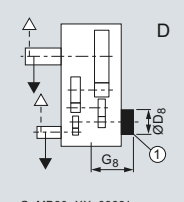
		
G_MD30_XX_00023	G_MD30_XX_00027	G_MD30_XX_00031

4

① Backstop

Helical gear units horizontal mounting position

Types H2, H3 and H4

Order number overview

Selection and ordering data (continued)

Order no. supplement 8th to 10th position

		Position	1 to 6	7	8	9	10	11	12	13	14	15	16
		Order number	2LP202		.	-	■	■	■
Output shaft, gear unit size													
Output shaft	Gear unit size												
Solid shaft (S)													
	504					3	A						
	505					4	A						
	506					5	A						
	507					6	A						
	508					7	A						
	509					8	A						
	510					0	B						
	511					1	B						
	512					2	B						
	513					3	B						
	514					4	B						
Hollow shaft with keyway (H)													
	504					3	D						
	505					4	D						
	506					5	D						
	507					6	D						
	508					7	D						
	509					8	D						
	510					0	E						
	511					1	E						
	512					2	E						
	513					3	E						
	514					4	E						
Hollow shaft for shrink disk (D)													
	504					3	G						
	505					4	G						
	506					5	G						
	507					6	G						
	508					7	G						
	509					8	G						
	510					0	H						
	511					1	H						
	512					2	H						
	513					3	H						
	514					4	H						
Gear unit type, number of stages, mounting position													
H2.H												L	
H3.H												M	
H4.H												N	

Helical gear units horizontal mounting position

Types H2, H3 and H4

Order number overview

Selection and ordering data (continued)

Order no. supplement 11th to 16th position

				Position	1 to 6	7	8	9	10	11	12	13	14	15	16	
				Order number	2	L	P	2	0	2	0	2	2	2	2	
Seal for shaft 1																
Input shaft with WDR											0					
Seal for shaft 2																
Output shaft with WDR											0					
Output shaft, taconite F											4					
Output shaft, taconite F-F											6					
Output shaft, taconite F-H											7					
Output shaft, taconite F-K											8					
Shaft variants																
Standard shaft D1 and standard shaft D2												0				
Gear ratio																
	Type															
	H2.H	H3.H	H4.H													
i_N	6.3	20	80												A	
i_N	7.1	22.4	90												B	
i_N	8	25	100												C	
i_N	9	28	112												D	
i_N	10	31.5	125												E	
i_N	11.2	35.5	140												F	
i_N	12.55	40	160												G	
i_N	14	45	180												H	
i_N	16	50	200												J	
i_N	18	56	224												K	
i_N	20	63	250												L	
i_N	22.4	71	280												M	
i_N	25	80	315												N	
i_N	–	90	355												P	
i_N	–	100	400												Q	
i_N	–	–	–												R	
Oil supply																
Dip lubrication																A
Auxiliary cooling																
Without auxiliary cooling																0
Auxiliary cooling with fan																1
Auxiliary cooling with cooling coil (mounted on end face D2)																2
Auxiliary cooling with fan and cooling coil (mounted on end face D2)																3
Auxiliary cooling with cooling coil (mounted on end face D1)																4
Auxiliary cooling with fan and cooling coil (mounted on end face D1)																5

Bevel-helical gear units horizontal mounting position

5

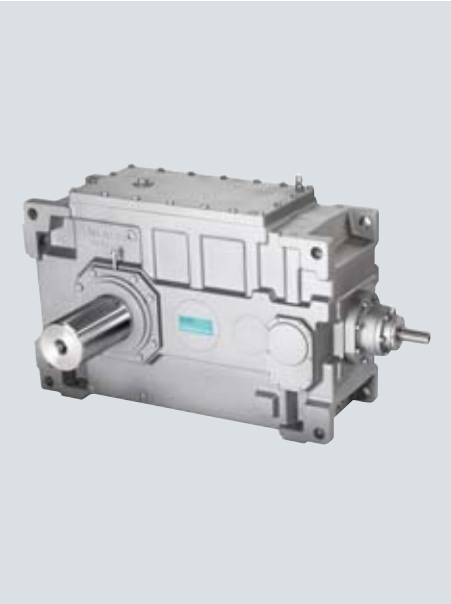

5/2

Type B3Gear unit dimensions

5/2

Three-stage, gear unit sizes 504 to 508

5/4

Three-stage, gear unit sizes 509 to 514

5/6

Type B4Gear unit dimensions

5/6

Four-stage, gear unit sizes 505 to 508

5/8

Four-stage, gear unit sizes 509 to 514

5/10

Types B3 and B4

Order number overview

Bevel-helical gear units horizontal mounting position

Type B3

Gear unit dimensions
Three-stage, gear unit sizes 504 to 508

Selection and ordering data

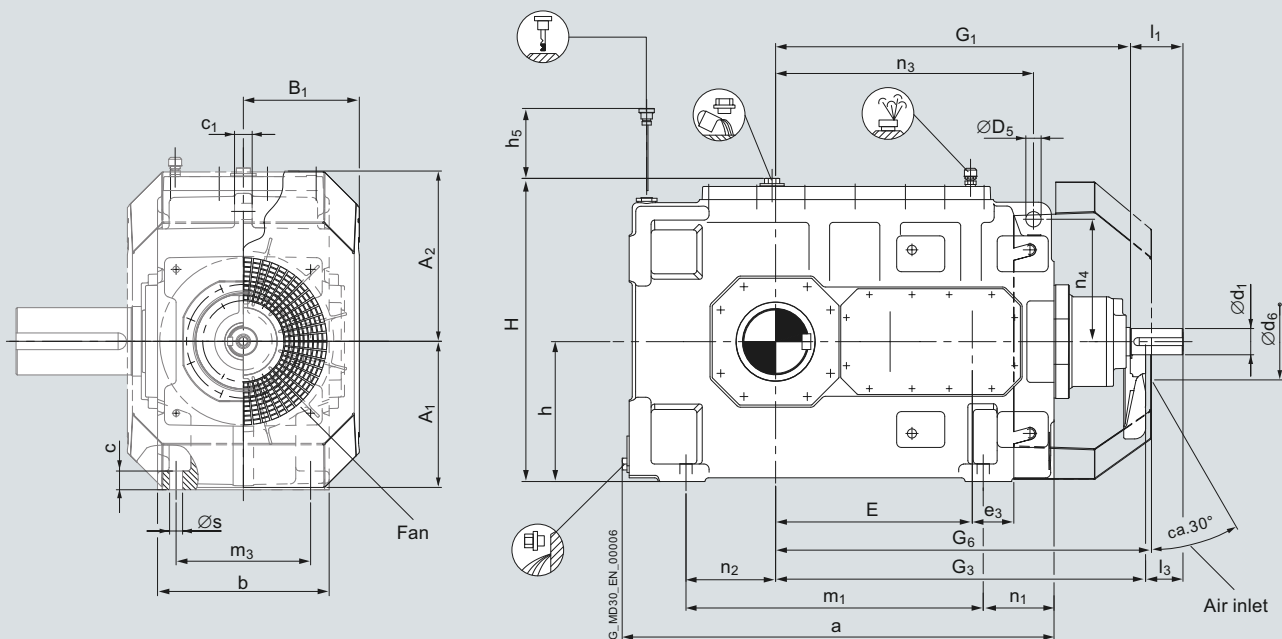

Gear unit sizes	Dimensions in mm												
	Input						Fan						
	d_1	l_1	l_3	d_1	l_1	l_3	G_1	G_3	A_1	A_2	B_1	d_6	G_6
504	$i_N = 14 - 56$	63											
	35 m6	80	60	32 m6	70	50	500	520	195	245	175	115	535
505	$i_N = 14 - 50$	56											
	40 m6	90	70	35 m6	80	60	575	595	225	275	195	135	605
506	$i_N = 20 - 71$	80											
	40 m6	90	70	35 m6	80	60	628	648	225	275	195	135	658
507	$i_N = 14 - 50$	56											
	50 m6	110	90	40 m6	90	70	690	710	275	330	225	160	725
508	$i_N = 18 - 63$	71											
	50 m6	110	90	40 m6	90	70	737	757	275	330	225	160	772

Gear unit sizes	Dimensions in mm																	Backstop ¹⁾	
	Gear units																	D_8	G_8
	a	b	c	c_1	D_5	E	e_3	H	h	h_5	m_1	m_3	n_1	n_2	n_3	n_4	s	D_8	G_8
504	604	210	28	18	19	269.5	110.5	440	200	340	415	170	95	130	355	175	19	125	210
505	684	250	30	27	24	310	130	510	230	380	490	200	95	145	405	202	19	150	230
506	807	250	30	27	24	363	130	510	230	380	613	200	95	215	458	202	19	150	230
507	855	295	35	30	28	384	160	610	280	430	595	230	129	180	505	250	24	175	295
508	962	295	35	30	28	431	160	610	280	430	702	230	129	240	552	250	24	175	295

Note: Refer to pages 6/2 to 6/5 for shaft details.

Bevel-helical gear units horizontal mounting position

Type B3

Gear unit dimensions
Three-stage, gear unit sizes 504 to 508

Selection and ordering data (continued)

Output

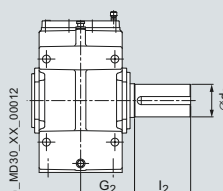
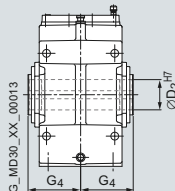
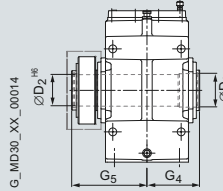
				Oil quantity 2)	Weight 2) 3)	For order no. supplement for 7th and 11th to 16th position, see pages 5/10 to 5/12		
Order No.:		2LP202 - - - B - - - - -						
Type	Size	d ₂	l ₂	G ₂	l	kg	Solid shaft	
B3SH	504	80 m6	170	140	10	195	3 A	
	505	100 m6	210	165	18	320	4 A	
	506	110 n6	210	165	19	380	5 A	
	507	120 n6	210	195	32	540	6 A	
	508	130 n6	250	195	35	630	7 A	
								
Type	Size	D ₂	G ₄		l	kg	Hollow shaft with keyway	
B3HH	504	80 H7	140		10	195	3 D	
	505	95 H7	165		18	320	4 D	
	506	105 H7	165		19	380	5 D	
	507	115 H7	195		32	540	6 D	
	508	125 H7	195		35	630	7 D	
								
Type	Size	D ₂	D ₃	G ₄	G ₅	l	kg	Hollow shaft for shrink disk
B3DH	504	85 H6	85	140	215	10	195	3 G
	505	100 H6	100	165	255	18	320	4 G
	506	110 H6	110	165	260	19	380	5 G
	507	120 H6	120	195	290	32	540	6 G
	508	130 H6	130	195	305	35	630	7 G
								

5

Design

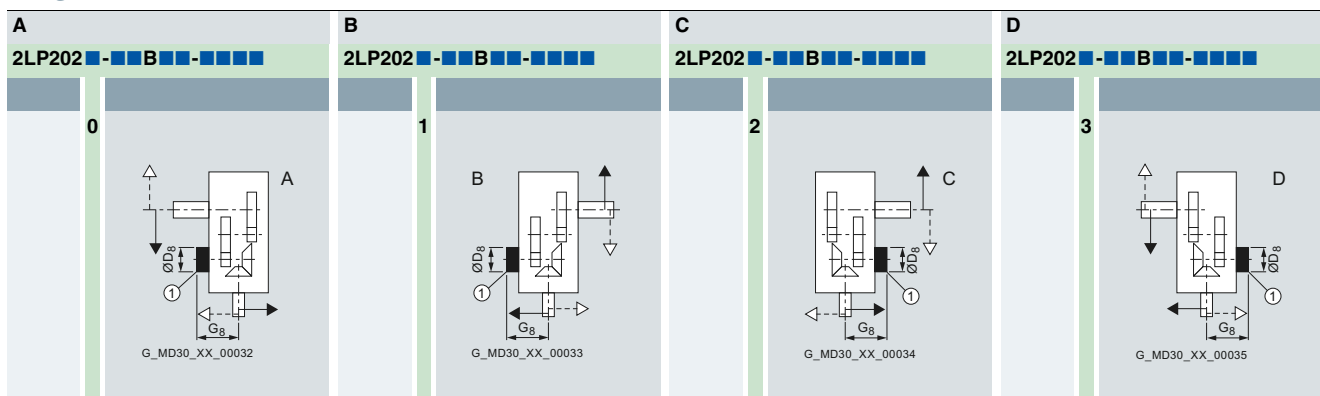

① Backstop

1) Max. dimensions; details acc. to order-related documentation.
 2) Approximate values; exact data acc. to order-related documentation.
 3) Without oil filling

Bevel-helical gear units horizontal mounting position

Type B3

Gear unit dimensions
Three-stage, gear unit sizes 509 to 514

Selection and ordering data

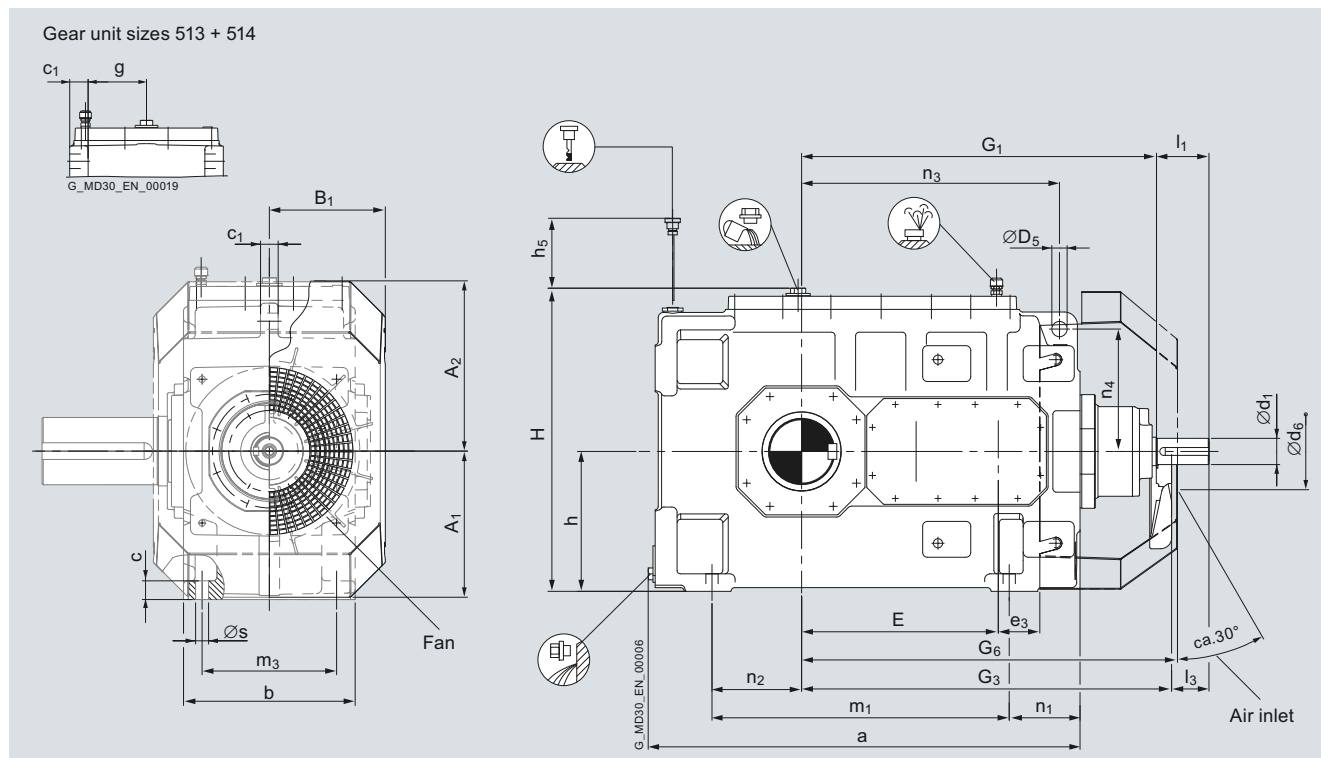

Gear unit sizes	Dimensions in mm												
	Input						Fan						
	d_1	l_1	l_3	d_1	l_1	l_3	G_1	G_3	A_1	A_2	B_1	d_6	G_6
509	$i_N = 14 - 50$	56											
	60 m6	120	90	50 m6	110	80	812	842	315	370	275	175	860
510	$i_N = 18 - 63$	71											
	60 m6	120	90	50 m6	110	80	865	895	315	370	275	175	913
511	$i_N = 14 - 50$	56											
	75 m6	135	100	60 m6	135	100	975	1010	375	440	305	175	1035
512	$i_N = 18 - 63$	71											
	75 m6	135	100	60 m6	135	100	1033	1068	375	440	305	175	1093
513	$i_N = 14 - 40$	45 - 56											
	80 m6	165	130	70 m6	140	110	1167	1202	425	435	350	190	1222
514	$i_N = 18 - 50$	56 - 71											
	80 m6	165	130	70 m6	140	110	1245	1280	425	435	350	190	1300

Gear unit sizes	Dimensions in mm																			Backstop ¹⁾	
	Gear units																			D_3	G_8
	a	b	c	c_1	D_5	E	e_3	g	H	h	h_5	m_1	m_3	n_1	n_2	n_3	n_4	s	D_3	G_8	
509	988	370	40	38	35	447	190	-	695	320	475	680	290	162	205	590	280	28	190	355	
510	1106	370	40	38	35	500	190	-	695	320	475	798	290	162	270	643	280	28	190	355	
511	1204	430	50	43	40	547	225	-	820	380	540	825	340	202	255	713	328	35	230	370	
512	1332	430	50	43	40	605	225	-	820	380	540	953	340	202	325	771	328	35	230	370	
513	1345	535	60	65	48	640	265	202.5	940	440	600	920	445	245	260	842	380	42	255	430	
514	1463	535	60	65	48	718	265	202.5	940	440	600	1038	445	245	300	920	380	42	255	430	

Note: Refer to pages 6/2 to 6/5 for shaft details.

Bevel-helical gear units horizontal mounting position

Type B3

Gear unit dimensions
Three-stage, gear unit sizes 509 to 514

Selection and ordering data (continued)

Output

				Oil quantity 2)		Weight 2) 3)		For order no. supplement for 7th and 11th to 16th position, see pages 5/10 to 5/12	
Order No.:		2LP202-■-■B■-■-■-■-■							
Type	Size	d ₂	l ₂	G ₂	l	kg		Solid shaft	
B3SH	509	145 n6	250	240	53	820	8 A		
	510	160 n6	300	240	55	1025	0 B		
	511	175 n6	300	270	84	1455	1 B		
	512	185 n6	350	270	89	1665	2 B		
	513	200 n6	350	330	145	2500	3 B		
	514	210 n6	350	330	155	2850	4 B		
Type	Size	D ₂		G ₄	l	kg		Hollow shaft with keyway	
B3HH	509	135 H7		235	53	820	8 D		
	510	150 H7		235	55	1025	0 E		
	511	165 H7		270	84	1455	1 E		
	512	180 H7		270	89	1665	2 E		
	513	190 H7		330	145	2500	3 E		
	514	210 H7		330	155	2850	4 E		
Type	Size	D ₂	D ₃	G ₄	G ₅	l	kg		Hollow shaft for shrink disk
B3DH	509	140 H6	145	235	350	53	820	8 G	
	510	150 H6	155	235	370	55	1025	0 H	
	511	165 H6	170	270	420	84	1455	1 H	
	512	180 H6	185	270	425	89	1665	2 H	
	513	190 H6	195	330	495	145	2500	3 H	
	514	210 H6	215	330	495	155	2850	4 H	

5

Design

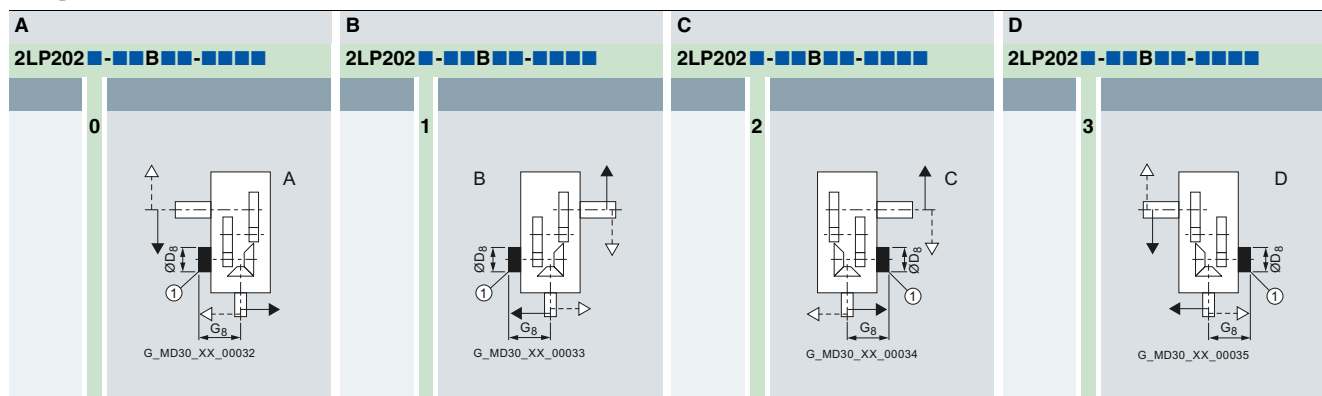

① Backstop

1) Max. dimensions; details acc. to order-related documentation.

2) Approximate values; exact data acc. to order-related documentation.

3) Without oil filling

Bevel-helical gear units horizontal mounting position

Type B4

Gear unit dimensions
Four-stage, gear unit sizes 505 to 508

Selection and ordering data

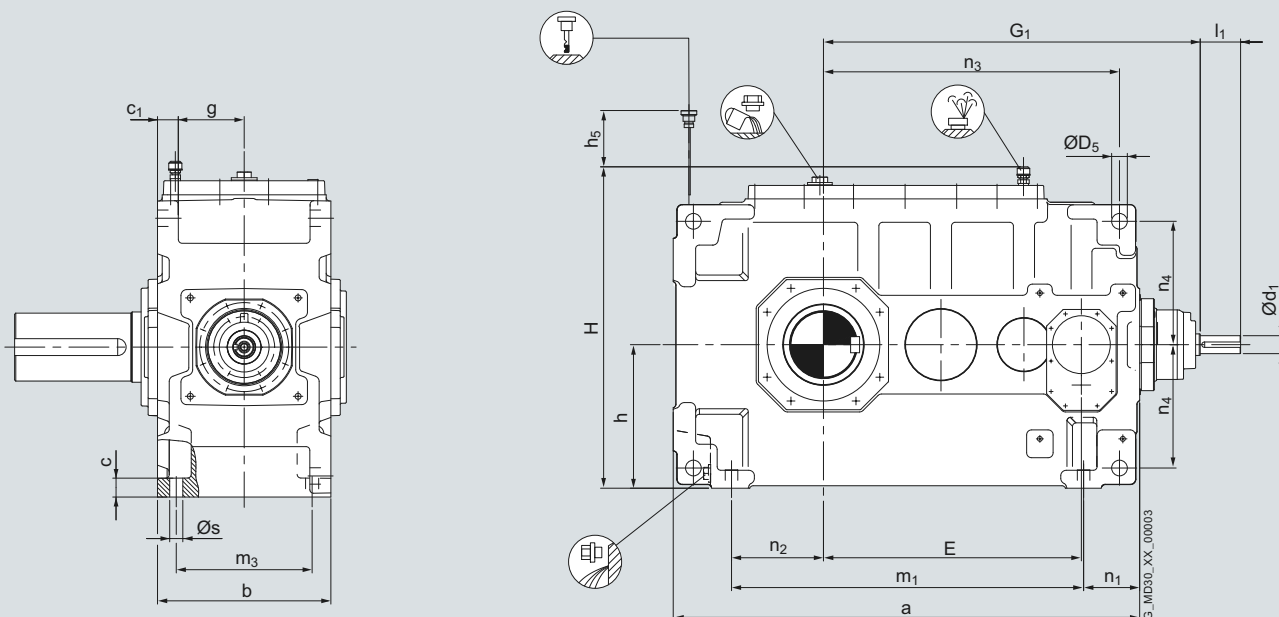

5

Gear unit sizes	Dimensions in mm						
	Input						
	d_1	l_1	d_1	l_1	d_1	l_1	G_1
505	$i_N = 63 - 200$ 28 m6 55	224 - 280 20 k6 50					610
506	$i_N = 90 - 280$ 28 m6 55	315 - 355 20 k6 50					663
507	$i_N = 63 - 200$ 35 m6 80	224 32 m6 70			250 - 280 25 k6 60		724
508	$i_N = 80 - 250$ 35 m6 80	280 32 m6 70			315 - 355 25 k6 60		771

Gear unit sizes	Dimensions in mm																	Backstop¹⁾		
	Gear units																			
	a	b	c	c_1	D_5	E	e_3	g	H	h	h_5	m_1	m_3	n_1	n_2	n_3	n_4	s	D_8	G_8
505	720	250	30	30	24	400	90	95	510	230	380	530	200	105	145	457.5	202.5	19	150	225
506	843	250	30	30	24	453	90	95	510	230	380	653	200	105	215	510.5	202.5	19	150	225
507	899	295	35	35	28 H9	493.5	110.5	112.5	610	280	430	680	230	104	180	567.5	242.5	24	102	245
508	1006	295	35	35	28 H9	540.5	110.5	112.5	610	280	430	787	230	104	240	614.5	242.5	24	102	245

Note: Refer to pages 6/2 to 6/5 for shaft details.

Bevel-helical gear units horizontal mounting position

Type B4

Gear unit dimensions
Four-stage, gear unit sizes 505 to 508

Selection and ordering data (continued)

Output

		Oil quantity 2)	Weight 2) 3)		For order no. supplement for 7th and 11th to 16th position, see pages 5/10 to 5/12				
Order No.:		2LP202 - ■ ■ C ■ ■ - ■ ■ ■ ■							
Type	Size	d_2	l_2	G_2	l	kg	Solid shaft		
B4SH	505	100 m6	210	165	19	330	4 A		
	506	110 n6	210	165	21	375	5 A		
	507	120 n6	210	195	35	530	6 A		
	508	130 n6	250	195	38	625	7 A		
Type	Size	D_2	G_4	l	kg	Hollow shaft with keyway			
B4HH	505	95 H7	165	19	330	4 D			
	506	105 H7	165	21	375	5 D			
	507	115 H7	195	35	530	6 D			
	508	125 H7	195	38	625	7 D			
Type	Size	D_2	D_3	G_4	G_5	l	kg	Hollow shaft for shrink disk	
B4DH	505	100 H6	100	165	255	19	330	4 G	
	506	110 H6	110	165	260	21	375	5 G	
	507	120 H6	120	195	290	35	530	6 G	
	508	130 H6	130	195	305	38	625	7 G	

5

Design

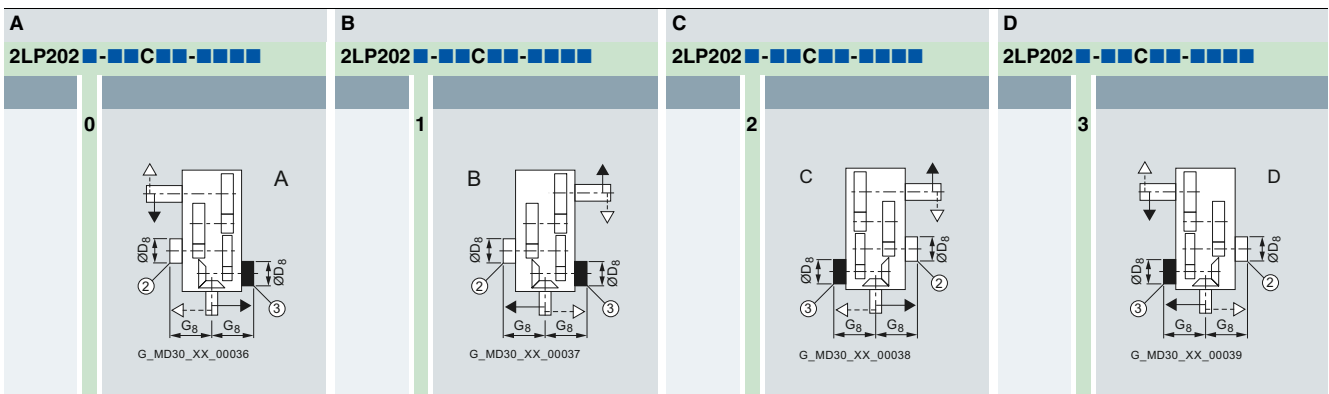

- ② Backstop for type B4, gear unit sizes 505 to 506
- ③ Backstop for type B4, gear unit sizes 507 to 514

1) Max. dimensions; details acc. to order-related documentation.
 2) Approximate values; exact data acc. to order-related documentation.
 3) Without oil filling

Bevel-helical gear units horizontal mounting position

Type B4

Gear unit dimensions
Four-stage, gear unit sizes 509 to 514

Selection and ordering data

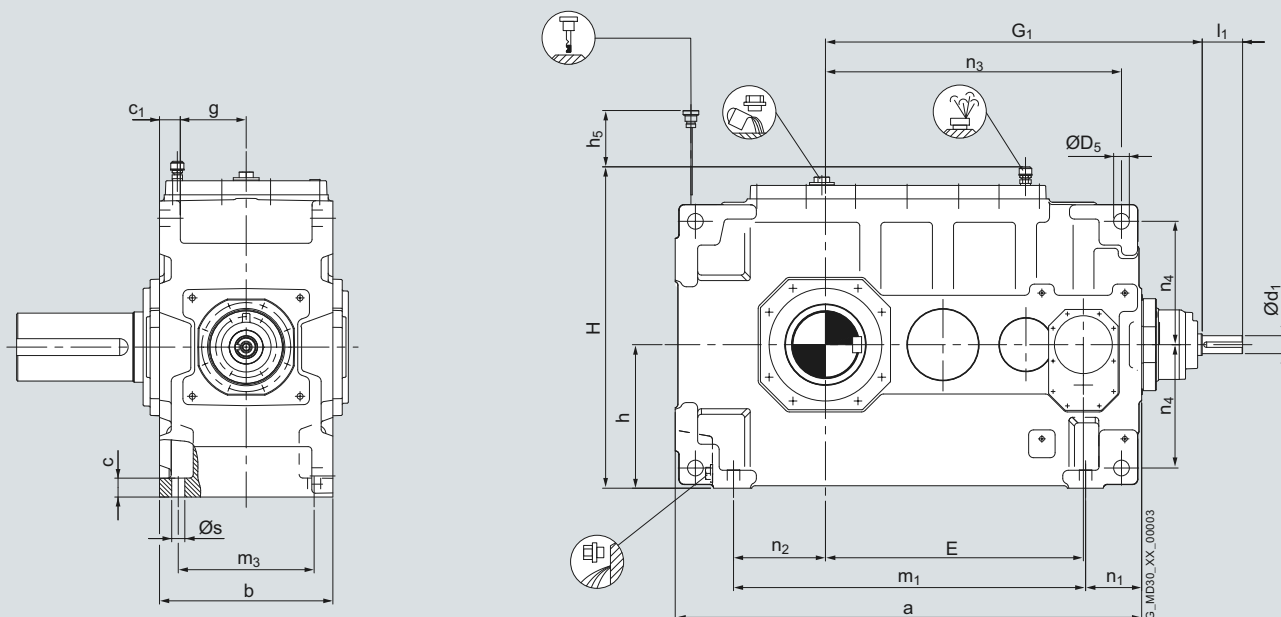

5

Gear unit sizes	Dimensions in mm				
	Input				
	d_1	l_1	d_1	l_1	G_1
509	$i_N = 63 - 200$ 40 m6 90	224 - 280 35 m6 80			840
510	$i_N = 80 - 250$ 40 m6 90	280 - 355 35 m6 80			893
511	$i_N = 63 - 200$ 50 m6 110	224 - 280 40 m6 90			1012
512	$i_N = 80 - 250$ 50 m6 110	280 - 355 40 m6 90			1070
513	$i_N = 63 - 200$ 60 m6 120	224 - 280 50 m6 110			1190
514	$i_N = 80 - 250$ 60 m6 120	280 - 355 50 m6 110			1268

Gear unit sizes	Dimensions in mm																		Backstop¹⁾	
	Gear units																			
	a	b	c	c_1	D_5	E	e_3	g	H	h	h_5	m_1	m_3	n_1	n_2	n_3	n_4	s	D_8	G_8
509	1040	370	40	45	35	575	130	140	695	320	475	785	290	125	205	458	275	28	125	285
510	1158	370	40	45	35	628	130	140	695	320	475	903	290	125	270	713	275	28	125	285
511	1281	430	50	60	40	706	160	155	820	380	540	960	340	161	255	812.5	330	35	150	335
512	1409	430	50	60	40	764	160	155	820	380	540	1088	340	161	325	870.5	330	35	150	335
513	1455	535	60	65	48	825	190	202.5	940	440	600	1092	445	183	260	952	380	42	175	405
514	1573	535	60	65	48	903	190	202.5	940	440	600	1210	445	183	300	1030	380	42	175	405

Note: Refer to pages 6/2 to 6/5 for shaft details.

Bevel-helical gear units horizontal mounting position

Type B4

Gear unit dimensions
Four-stage, gear unit sizes 509 to 514

Selection and ordering data (continued)

Output

				Oil quantity 2)		Weight 2) 3)		For order no. supplement for 7th and 11th to 16th position, see pages 5/10 to 5/12		
Order No.:		2LP202-■-■C■-■-■-■								
Type	Size	d ₂	l ₂	G ₂	l	kg	Solid shaft			
B4SH	509	145 n6	250	240	58	830	8 A			
	510	160 n6	300	240	60	995	0 B			
	511	175 n6	300	270	93	1425	1 B			
	512	185 n6	350	270	103	1630	2 B			
	513	200 n6	350	330	160	2400	3 B			
	514	210 n6	350	330	165	2695	4 B			
Type	Size	D ₂	G ₄		l	kg	Hollow shaft with keyway			
B4HH	509	135 H7	235		58	830	8 D			
	510	150 H7	235		60	995	0 E			
	511	165 H7	270		93	1425	1 E			
	512	180 H7	270		103	1630	2 E			
	513	190 H7	330		160	2400	3 E			
	514	210 H7	330		165	2695	4 E			
Type	Size	D ₂	D ₃	G ₄	G ₅	l	kg	Hollow shaft for shrink disk		
B4DH	509	140 H6	145	235	350	58	830	8 G		
	510	150 H6	155	235	370	60	995	0 H		
	511	165 H6	170	270	420	93	1425	1 H		
	512	180 H6	185	270	425	103	1630	2 H		
	513	190 H6	195	330	495	160	2400	3 H		
	514	210 H6	215	330	495	165	2695	4 H		

5

Design

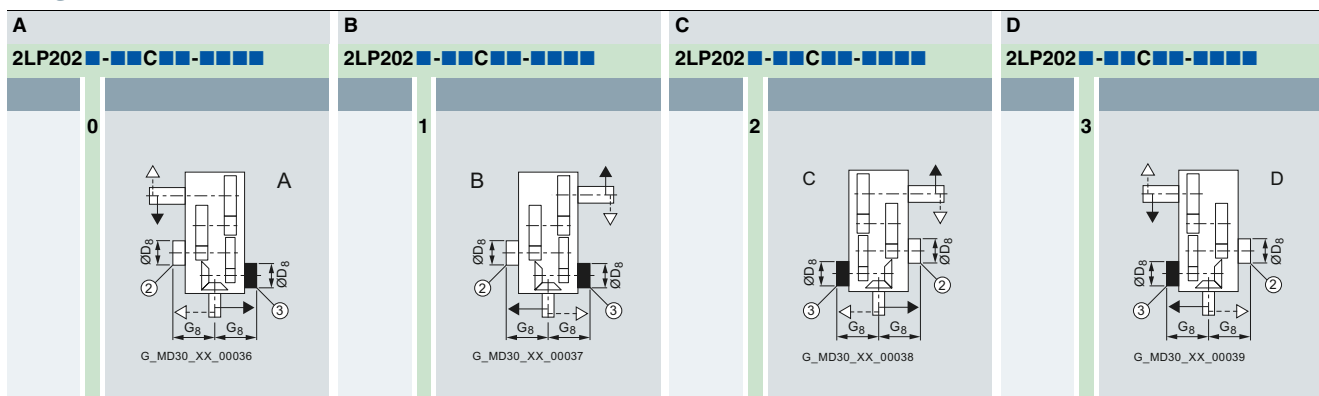

② Backstop for type B4, gear unit sizes 505 to 506

③ Backstop for type B4, gear unit sizes 507 to 514

1) Max. dimensions; details acc. to order-related documentation.

2) Approximate values; exact data acc. to order-related documentation.

3) Without oil filling

Bevel-helical gear units horizontal mounting position

Types B3 and B4

Order number overview

Selection and ordering data

Order no. supplement 7th position

Position	1 to 6	7	8	9	10	11	12	13	14	15	16
Order number	2LP202 -										

Design

Type	B3.H	B4.H
------	------	------

A			0
B			1
C			2
D			3

5

- ① Backstop for type B3
- ② Backstop for type B4, gear unit sizes 505 to 506
- ③ Backstop for type B4, gear unit sizes 507 to 514

Bevel-helical gear units horizontal mounting position

Types B3 and B4

Order number overview

Selection and ordering data (continued)

Order no. supplement 8th to 10th position

		Position	1 to 6	7	8	9	10	11	12	13	14	15	16
		Order number	2LP202		.	-	■	■	■
Output shaft, gear unit size													
Output shaft	Gear unit size												
Solid shaft (S)													
	504					3	A						
	505					4	A						
	506					5	A						
	507					6	A						
	508					7	A						
	509					8	A						
	510					0	B						
	511					1	B						
	512					2	B						
	513					3	B						
	514					4	B						
Hollow shaft with keyway (H)													
	504					3	D						
	505					4	D						
	506					5	D						
	507					6	D						
	508					7	D						
	509					8	D						
	510					0	E						
	511					1	E						
	512					2	E						
	513					3	E						
	514					4	E						
Hollow shaft for shrink disk (D)													
	504					3	G						
	505					4	G						
	506					5	G						
	507					6	G						
	508					7	G						
	509					8	G						
	510					0	H						
	511					1	H						
	512					2	H						
	513					3	H						
	514					4	H						
Gear unit type, number of stages, mounting position													
B3.H												B	
B4.H												C	

Bevel-helical gear units horizontal mounting position

Types B3 and B4

Order number overview

Selection and ordering data (continued)

Order no. supplement 11th to 16th position

		Position	1 to 6	7	8	9	10	11	12	13	14	15	16
		Order number	2	L	P	2	0	2	0	2	0	2	0
Seal for shaft 1													
Input shaft with WDR									0				
Input shaft with taconite E									4				
Seal for shaft 2													
Output shaft with WDR									0				
Output shaft, taconite F									4				
Output shaft, taconite F-F									6				
Output shaft, taconite F-H									7				
Output shaft, taconite F-K									8				
Shaft variants													
Standard shaft D1 and standard shaft D2													0
Gear ratio													
	Type												
	B3.H	B4.H											
i_N	14	63											A
i_N	16	71											B
i_N	18	80											C
i_N	20	90											D
i_N	22.4	100											E
i_N	25	112											F
i_N	28	125											G
i_N	31.5	140											H
i_N	35.5	160											J
i_N	40	180											K
i_N	45	200											L
i_N	50	224											M
i_N	56	250											N
i_N	63	280											P
i_N	71	315											Q
i_N	80	355											R
Oil supply													
Dip lubrication													A
Auxiliary cooling													
Without auxiliary cooling													0
Auxiliary cooling with fan													1
Auxiliary cooling with cooling coil (mounted on end face D2)													2
Auxiliary cooling with fan and cooling coil (mounted on end face D2)													3
Auxiliary cooling with cooling coil (mounted on end face D1)													4

5

Connection dimensions



6/2	Cylindrical shaft ends
6/2	Central holes, form DS in shaft ends DIN 332/1
6/3	Selection of fit
6/4	Parallel keys, parallel keyways and hollow shafts with keyway
6/5	Hollow shafts for shrink disk
6/6	Hollow shaft with keyway to DIN 6885/1

Connection dimensions

Cylindrical shaft ends

Central holes, form DS
in shaft ends DIN 332/1

Dimensioned drawings

Form DS with thread, straight running surface and protective counterbore

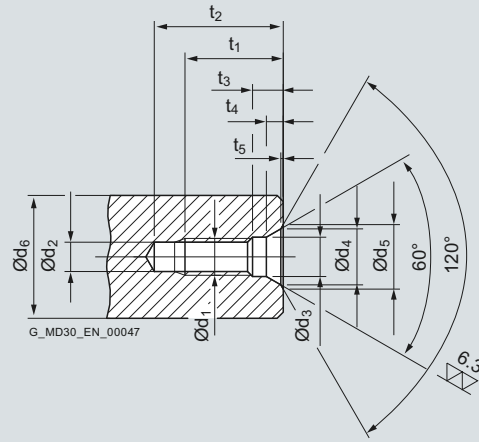

Recommended diameter ranges d_6 ¹⁾		Form DS DS centering	d_1	d_2 ²⁾	d_3	d_4	d_5	t_1 +2	t_2		t_3	t_4	t_5
above mm	to mm								min.	max.			
16	21	DS 6	M 6	5.0	6.4	9.6	10.5	16.0	21	23	5.0	2.8	0.4
21	24	DS 8	M 8	6.8	8.4	12.2	13.2	19.0	25	28	6.0	3.3	0.4
24	30	DS 10	M 10	8.5	10.5	14.9	16.3	22.0	30	34	7.5	3.8	0.6
30	38	DS 12	M 12	10.2	13.0	18.1	19.8	28.0	37	42	9.5	4.4	0.7
38	50	DS 16	M 16	14.0	17.0	23.0	25.3	36.0	45	50	12.0	5.2	1.0
50	85	DS 20	M 20	17.5	21.0	28.4	31.3	42.0	53	59	15.0	6.4	1.3
85	130	DS 24	M 24	21.0	25.0	34.2	38.0	50.0	63	68	18.0	8.0	1.6
130	225	DS 30 ³⁾	M 30	26.5	31.0	40.2	44.6	60.0	77	83	17.0	8.0	1.9
225	320	DS 36 ³⁾	M 36	32.0	37.0	49.7	55.0	74.0	93	99	22.0	11.0	2.3
320	500	DS 42 ³⁾	M 42	37.5	43.0	60.3	66.6	84.0	105	111	26.0	15.0	2.7

¹⁾ Diameter refers to the finished workpiece

²⁾ Tap hole drill diameter acc. to DIN 336 Part 1

³⁾ Dimensions not acc. to DIN 332

Connection dimensions

Cylindrical shaft ends

Selection of fit

Overview

Selection of fit

Selection of fit	Shaft d		Shaft tolerance	Bore tolerance
	above	to		
	mm	mm		
Shaft tolerance acc. to Flender standard		25	k6	H7
	25	100	m6	
	100		h6	

For heavy-duty operating conditions, e.g. reversing under load, it is recommended that a tighter fit and for the hub keyway width the ISO tolerance P9 is selected (special design).

In this case, the customer should give the relevant information.

Connection dimensions

Parallel keys, parallel keyways and hollow shafts with keyway

Overview (continued)

Parallel keys and parallel keyways

Drive type fastening without taper action

Parallel key and keyway to DIN 6885/1

Parallel key form B

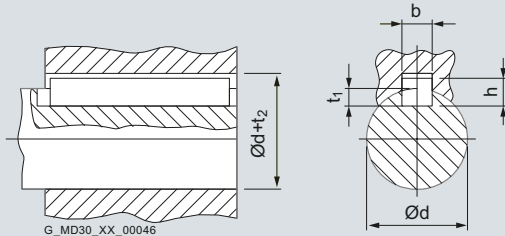

G_MD30_XX_00046

Diameter		Width	Height	Depth of keyway	Depth of keyway
d		b ¹⁾	h	in shaft	in hub
above	to			t ₁	d + t ₂
mm	mm	mm	mm	mm	mm
17	22	6	6	3.5	d + 2.8
22	30	8	7	4	d + 3.3
30	38	10	8	5	d + 3.3
38	44	12	8	5	d + 3.3
44	50	14	9	5.5	d + 3.8
50	58	16	10	6	d + 4.3
58	65	18	11	7	d + 4.4
65	75	20	12	7.5	d + 4.9
75	85	22	14	9	d + 5.4
85	95	25	14	9	d + 5.4
95	110	28	16	10	d + 6.4
110	130	32	18	11	d + 7.4
130	150	36	20	12	d + 8.4
150	170	40	22	13	d + 9.4
170	200	45	25	15	d + 10.4
200	230	50	28	17	d + 11.4
230	260	56	32	20	d + 12.4
260	290	63	32	20	d + 12.4
290	330	70	36	22	d + 14.4
330	390	80	40	25	d + 15.4
390	440	90	45	28	d + 17.4

For heavy-duty operating conditions, e.g. reversing under load, it is recommended that a tighter fit and for the hub keyway width the ISO tolerance P9 is selected (special design). In this case, the customer should give the relevant information.

¹⁾ The tolerance zone for the hub keyway width b is ISO JS9, or ISO P9 for heavy duty operating conditions (P9 special design).

Connection dimensions

Hollow shafts for shrink disk

Dimensioned drawings

Types H2D., H3D., H4D., B3D., B4D.

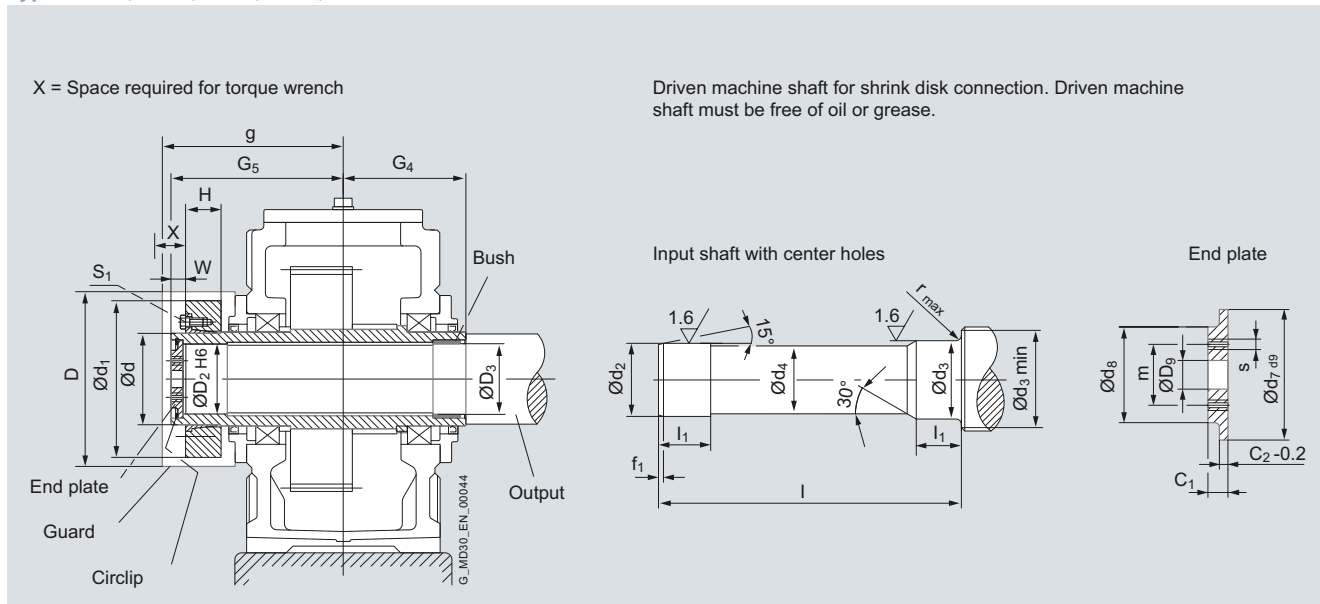

Gear unit sizes	Dimensions in mm																											
	Driven machine shaft ¹⁾														End plate				Circlip	Hollow shaft		Shrink disk ²⁾				Screw	Guard	
	d ₂	d ₃	d ₄	d ₅	f ₁	l	l ₁	r	c ₁	c ₂	d ₇	d ₈	D ₉	m	s	Qty.	DIN 472	D ₂	D ₃	G ₄	G ₅	d	d ₁	H	W	s ₁	D	g
504	85 g6	85 h6	84.5	95 4	336	53 2	17	7	90	70 22	50 M8	2	90 x 3	85	85	140	215	110	185	54	22	M12	250	235				
505	100 g6	100 h6	99.5	114 5	398	59 2	20	8	105	80 26	55 M10	2	105 x 4	100	100	165	255	125	215	60	26	M12	290	275				
506	110 g6	110 h6	109.5	124 5	403	64 3	20	8	115	85 26	60 M10	2	115 x 4	110	110	165	260	140	240	67	26	M14	320	280				
507	120 g6	120 h6	119.5	134 5	463	68 3	20	8	125	90 26	65 M12	2	125 x 4	120	120	195	290	150	263	71	26	M14	350	310				
508	130 g6	130 h6	129.5	145 6	478	81 3	20	8	135	100 26	70 M12	2	135 x 4	130	130	195	305	165	290	81	27	M16	380	320				
509	140 g6	145 m6	139.5	160 6	559	85 4	23	10	150	110 33	80 M12	2	150 x 4	140	145	235	350	175	300	86	31	M16	380	375				
510	150 g6	155 m6	149.5	170 6	579	101 4	23	10	160	120 33	90 M12	2	160 x 4	150	155	235	370	185	320	101	31	M16	410	395				
511	165 f6	170 m6	164.5	185 7	664	119 4	23	10	175	130 33	90 M12	2	175 x 4	165	170	270	420	200	340	118	32	M16	460	445				
512	180 f6	185 m6	179.5	200 7	669	125 4	23	10	190	140 33	100 M16	2	190 x 4	180	185	270	425	220	370	125	32	M20	480	450				
513	190 f6	195 m6	189.5	213 7	799	130 5	23	10	200	150 33	110 M16	2	200 x 4	190	195	330	495	240	405	131	32	M20	530	520				
514	210 f6	215 m6	209.5	233 8	794	124 5	28	14	220	170 33	130 M16	2	220 x 5	210	215	330	495	260	340	126	38	M20	550	520				

¹⁾ Material of driven machine shaft C60N or higher strength.
²⁾ Shrink disk is not included in our scope of supply. Please order separately, if required. In case of order, shrink disk is supplied loose.

Connection dimensions

Hollow shaft with keyway to DIN 6885/1

Dimensioned drawings

Types H2H., H3H., H4H., B3H., B4H.

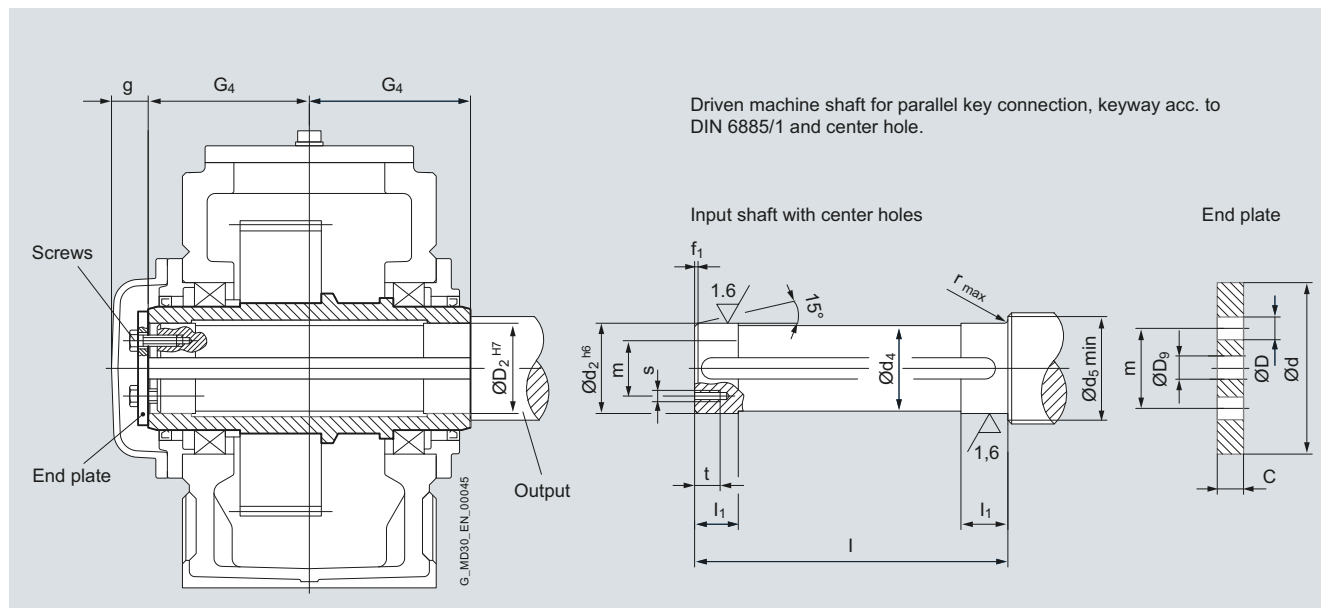

6

Gear unit sizes	Dimensions in mm																		
	Driven machine shaft ¹⁾										End plate			Bolt		Hollow shaft			
	d ₂	d ₄	d ₅	f ₁	l	l ₁	r	s	t	c	D	D ₉	d	m	Size	Qty.	D ₂	G ₄	g
504	80	79.5	88	4	278	35	1.2	M 10	18	10	11	22	100	60	M 10 x 25	2	80	140	35
505	95	94.5	105	5	328	40	1.6	M 10	18	10	11	26	120	70	M 10 x 25	2	95	165	40
506	105	104.5	116	5	328	45	1.6	M 10	18	10	11	26	120	70	M 10 x 25	2	105	165	40
507	115	114.5	126	5	388	50	1.6	M 12	20	12	13.5	26	140	80	M 12 x 30	2	115	195	40
508	125	124.5	136	6	388	55	2.5	M 12	20	12	13.5	26	150	85	M 12 x 30	2	125	195	40
509	135	134.5	147	6	467	60	2.5	M 12	20	12	13.5	33	160	90	M 12 x 30	2	135	235	45
510	150	149.5	162	6	467	65	2.5	M 12	20	12	13.5	33	185	110	M 12 x 30	2	150	235	45
511	165	164.5	177	7	537	70	2.5	M 16	28	15	17.5	33	195	120	M 16 x 40	2	165	270	45
512	180	179.5	192	7	537	75	2.5	M 16	28	15	17.5	33	220	130	M 16 x 40	2	180	270	45
513	190	189.5	206	7	657	80	3	M 16	28	18	17.5	33	230	140	M 16 x 40	2	190	330	45
514	210	209.5	226	8	657	85	3	M 16	28	18	17.5	33	250	160	M 16 x 40	2	210	330	45

Note: Parallel key is not included in our scope of supply Please order separately, if required.

¹⁾ Material of driven machine shaft C60N or higher strength.

Options for operation



7/2	Shaft seals
7/2	Radial shaft seal
7/2	Taconite
7/3	Cooling
7/3	Fan
7/3	Cooling coil

Options for operation

Shaft seals

Radial shaft seal Taconite

Overview

Radial shaft seal

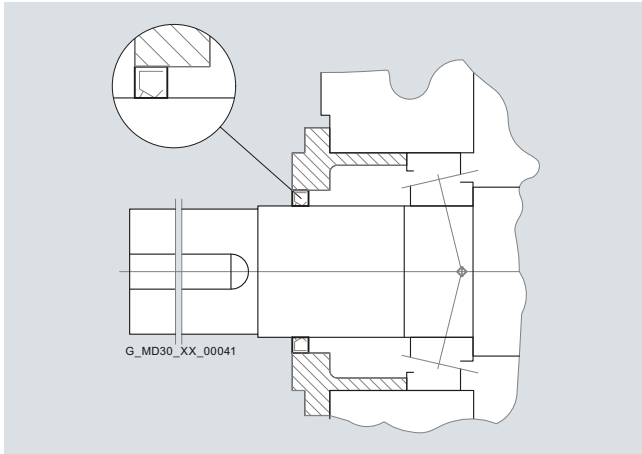

Radial shaft seals are suitable for low to average operating speeds. They can be used for all types and sizes.

Other features are:

- Wearing seal, however, easy to maintain
- Local heat development on sealing lip; therefore, adequate lubrication (cooling) required
- Commercial product
- Design with low oil level on request

Taconite

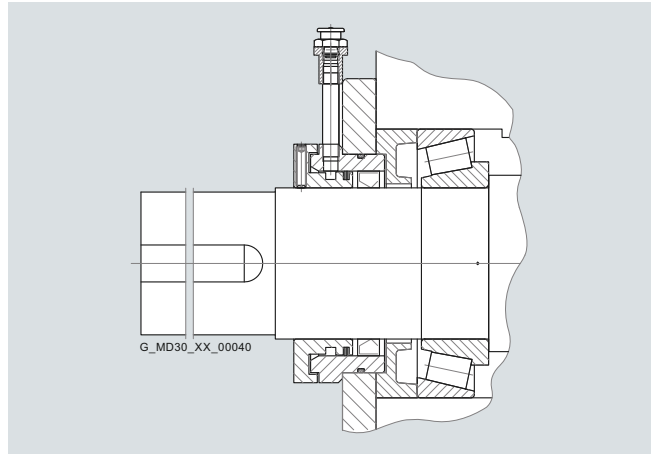

Taconite seals are grease-filled, refillable labyrinth seal combinations.

With this seal a high degree of operational reliability is achieved for the gear unit in dusty environments. This seal is a combination of three sealing elements which protect the gear unit from ingress of dust-like particles.

When motor bell housings are used in accordance with the section on motor connection, taconite E seals are not required because the coupling enclosure is sealed dust-tight.

Ordering information

Order No.:		2LP202 ■■■■■ -0 ■ A ■	
Input shaft with WDR		0	
Output shaft with WDR		0	

Ordering information

Order No.:		2LP202 ■■■■■ -0 ■ A ■	
Input shaft with taconite E		4	
Output shaft with taconite F	For gear unit with solid shaft (..S.)	4	
Output shaft with taconite F-F	For gear units with hollow shaft with keyway (..H.) or hollow shaft for shrink disk (..D.):	6	
	<ul style="list-style-type: none"> • Taconite seals on both sides • Guard as protection against accidental contact 		
Output shaft with taconite F-H	For gear units with hollow shaft with keyway (..H.):	7	
	<ul style="list-style-type: none"> • Taconite seal on driven machine shaft • Dustproof guard on opposite side 		
Output shaft with taconite F-K	For gear units with hollow shaft for shrink disk (..D.):	8	
	<ul style="list-style-type: none"> • Taconite seal on driven machine shaft • Dustproof guard on opposite side 		

Overview**Fan and cooling coil**

Fans and/or cooling coils can be used for auxiliary cooling.

Fan:

- The fan is mounted on the input shaft (= fast rotating shaft)
- An adapted air guide cover ensures optimized air flow on the gear unit and therefore high-performance cooling
- A fan can be retrofitted
- The connection dimensions at the input shaft are changed if a fan is mounted

Cooling coil:

- The cooling coil is mounted on end face D2
- It can be mounted on end face D1 on request
- The cooling coil is suitable for freshwater, seawater and brackish water
- See table for connection dimensions
- Water connection: G 1/2"

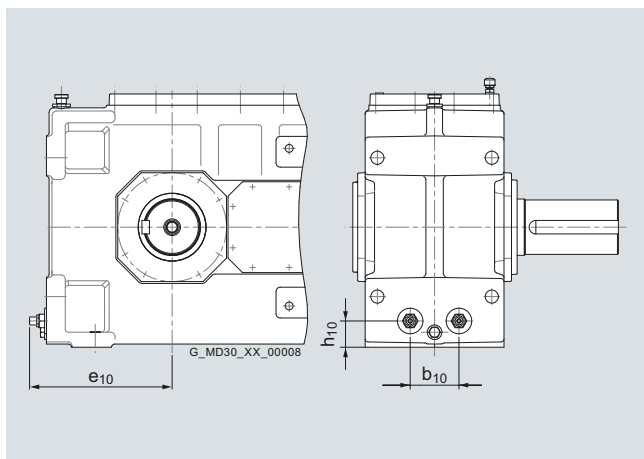

Gear unit sizes	Cooling coil				
	Dimensions in mm			l/min ¹⁾	
	b ₁₀	e ₁₀	h ₁₀	H2/B3	H3
504	80	250	40	4	4
505	95	275	45	4	4
506	95	345	45	4	4
507	100	340	60	4	4
508	100	400	60	4	4
509	130	385	70	8	4
510	130	450	70	8	4
511	150	465	80	8	8
512	150	535	80	8	8
513	160	380	85	8	8
514	160	420	85	8	8

Ordering information

Order No.:	2LP202 ■ - ■ ■ ■ ■ ■ - 0 ■ ■ A ■
Without auxiliary cooling	0
Auxiliary cooling with:	
• Fan	1
• Cooling coil (mounted on end face D2)	2
• Fan and cooling coil (mounted on end face D2)	3
• Cooling coil (mounted on end face D1)	4
• Fan and cooling coil (mounted on end face D1)	5

¹⁾ Necessary cooling water quantity, max. cooling water pressure: 8 bar

Options for operation

Cooling

Notes

7

Motor connection



	Motor bell housing for IEC motors
8/2	Type H2, gear unit sizes 504 to 512 with N-EUPEX coupling
8/4	Type H3, gear unit sizes 505 to 514 with N-EUPEX coupling
8/6	Type H4, gear unit sizes 507 to 514 with N-EUPEX coupling
8/8	Type B3, gear unit sizes 504 to 514 with N-EUPEX coupling
8/10	Type B4, gear unit sizes 505 to 514 with N-EUPEX coupling
8/12	Fitting dimensions for IEC motors

Motor connection

Motor bell housing for IEC motors

Type H2, gear unit sizes 504 to 512
with N-EUPEX coupling

Design

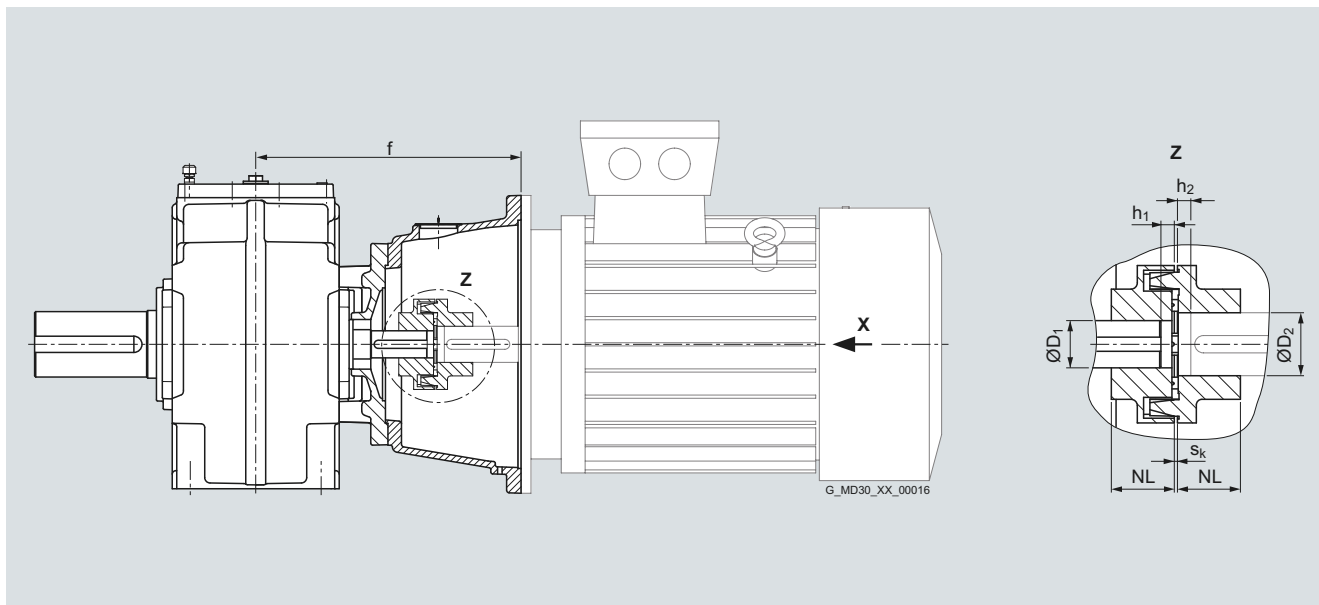

- For plants with special design requirements (high switching frequency, alternating direction of load; e.g. hoisting gears, traveling gears, etc.) the coupling design is to be checked in accordance with the respective valid coupling brochure. For other couplings, please consult us.
- For fitting dimensions for IEC standard motors DIN EN 50347 (View X), see page 8/12.
- Helical gear unit in C and D design, on request only.
- For type H2D. Design A and B, on request only.
- Not in connection with taconite E on input shaft (see note on page 7/2).

Gear unit sizes	Dimensions in mm																
	Basic dimensions					Ratio range 1				Ratio range 2				Ratio range 3			
	IEC motor ¹⁾	N-EUPEX	S _k	NL	D ₂	D ₁	h ₁	h ₂	f	D ₁	h ₁	h ₂	f	D ₁	h ₁	h ₂	f
504						<i>i_N</i> = 6.3 - 11.2				<i>i_N</i> = 12.5 - 16				<i>i_N</i> = 18 - 20			
	160M	B110	3	40	42					35	0	0	363	28	2	8	363
	160L	B110	3	40	42					35	0	0	363	28	2	8	363
	180M	B110	3	40	48					35	0	0	363	28	2	8	363
	180L	B125	3	50	48					35	0	0	363	28	5	5	363
	200L	B140	3	55	55	45	0	0	383	35	7	13	383	28	0	0	353
	225S ³⁾	B140	3	55	60	45	7	11	431	35	7	7	407	28	0	2	385
	225M ³⁾	B140	3	55	60	45	7	11	431	35	7	7	407	28	0	2	385
	250M ³⁾	B160	4	60	65	45	2	3	419	35	8	17	419				
505						<i>i_N</i> = 6.3 - 10				<i>i_N</i> = 11.2 - 14				<i>i_N</i> = 16 - 18			
506						<i>i_N</i> = 9 - 14				<i>i_N</i> = 16 - 20				<i>i_N</i> = 22.4 - 25			
	225S	B140	3	55	60					45	0	2	440	32	0	0	418
	225M	B140	3	55	60					45	0	2	440	32	0	0	418
	250M ³⁾	B160	4	60	65	60	8	10	482	45	6	7	452				
		B180	4	70	65									32	10	23	452
	280S ³⁾	B180	4	70	75	60	9	9	482	45	6	7	452				
	280M ³⁾	B180	4	70	75	60	9	9	482	45	6	7	452				
	315S ³⁾	B200	4	80	80	60	12	22	528	45	0	14	483				
	315M ³⁾	B200	4	80	80	60	12	22	528	45	0	14	483				
	315L ^{2) 3)}	B225	4	90	80	60	15	19	528								

Motor connection

Motor bell housing for IEC motors

Type H2, gear unit sizes 504 to 512
with N-EUPEX coupling

Design (continued)

Gear unit sizes	Dimensions in mm																
	Basic dimensions					Ratio range 1				Ratio range 2				Ratio range 3			
	IEC motor ¹⁾	N-EUPEX	S _k	NL	D ₂	D ₁	h ₁	h ₂	f	D ₁	h ₁	h ₂	f	D ₁	h ₁	h ₂	f
507						$i_N = 6.3 - 10$				$i_N = 11.2 - 18$							
508						$i_N = 8 - 12.5$				$i_N = 14 - 22.4$							
	225S	B140	3	55	60					50	0	1.5	469.5				
		B180	4	70	60	70	-0.5	0	493.5								
	225M	B140	3	55	60					50	0	1.5	469.5				
		B180	4	70	60	70	-0.5	0	493.5								
	250M	B160	4	60	65					50	6	6.5	481.5				
		B180	4	70	65	70	8	9.5	511.5								
	280S	B180	4	70	75	70	8	9.5	511.5	50	6	6.5	481.5				
	280M	B180	4	70	75	70	8	9.5	511.5	50	6	6.5	481.5				
	315S ³⁾	B200	4	80	80	70	12	21.5	557.5	50	0	13.5	512.5				
	315M ³⁾	B200	4	80	80	70	12	21.5	557.5	50	0	13.5	512.5				
	315L ²⁾³⁾	B225	4	90	80	70	15	18.5	557.5								
509						$i_N = 6.3 - 10$				$i_N = 11.2 - 14$				$i_N = 16 - 20$			
510						$i_N = 8 - 12.5$				$i_N = 14 - 18$				$i_N = 20 - 22.4$			
	280M	B180	4	70	75									50	3	3	500
	315S ³⁾	B200	4	80	80					60	10	12	576	50	0	7	531
	315M ³⁾	B200	4	80	80					60	10	12	576	50	0	7	531
	315L ²⁾³⁾	B225	4	90	80					60	10	12	576				
	315 ³⁾⁴⁾	On request				80	On request			60	On request						
511										$i_N = 11.2 - 14$				$i_N = 16 - 20$			
512										$i_N = 14 - 18$				$i_N = 20 - 22.4$			
	315 ³⁾⁴⁾	On request								80	On request			70	On request		

¹⁾ Other motor sizes on request.

²⁾ Siemens designation (size not included in DIN EN 50347)

³⁾ Notice: Motor flange radius $\varnothing P/2$ is greater than gear unit axis height h!

⁴⁾ Siemens designation non-standard motor (corresponds to LOHER designation 355M/L)

Motor connection

Motor bell housing for IEC motors

Type H3, gear unit sizes 505 to 514 with N-EUPEX coupling

Design

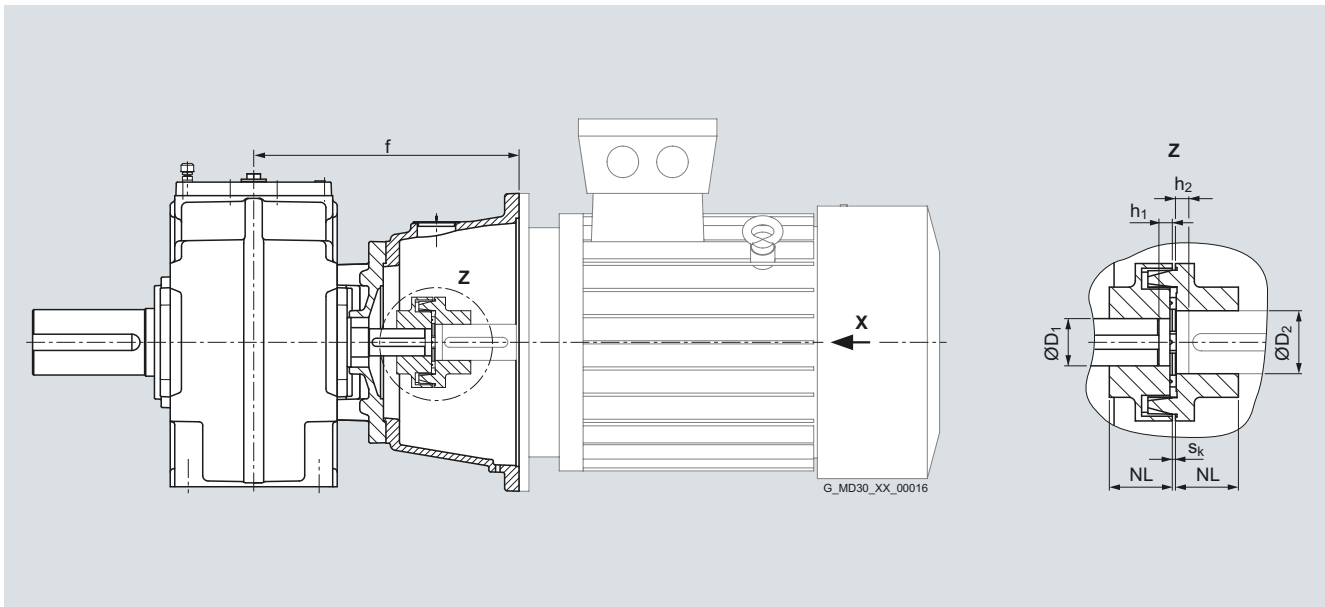

- For plants with special design requirements (high switching frequency, alternating direction of load; e.g. hoisting gears, traveling gears, etc.) the coupling design is to be checked in accordance with the respective valid coupling brochure. For other couplings, please consult us.
- For fitting dimensions for IEC standard motors DIN EN 50347 (View X), see page 8/12.
- Not in connection with taconite E on input shaft (see note on page 7/2).

Gear unit sizes	Dimensions in mm																
	Basic dimensions					Ratio range 1				Ratio range 2				Ratio range 3			
	IEC motor ¹⁾	N-EUPEX	S _k	NL	D ₂	D ₁	h ₁	h ₂	f	D ₁	h ₁	h ₂	f	D ₁	h ₁	h ₂	f
505						i _N = 20 - 40				i _N = 45 - 56				i _N = 63 - 71			
506						i _N = 28 - 56				i _N = 63 - 80				i _N = 90 - 100			
	132S	B080	3	30	38					30	0	3.5	336.5				
		B095	3	35	38	40	0	7	360					24	4	9.5	336.5
	132M	B095	3	35	38	40	0	7	360	30	0	3.5	336.5	24	4	9.5	336.5
	160M	B095	3	35	42	40	0	7	390	30	0	0	363	24	4	6	363
	160L	B110	3	40	42	40	2	5	390	30	0	0	363	24	2	8	363
	180M	B110	3	40	48	40	2	5	390	30	0	0	363	24	2	8	363
	180L	B125	3	50	48	40	3	4	390	30	0	0	363	24	5	5	363
	200L	B140	3	55	55	40	7	20	410	30	7	10	380	24	7	20	380
	225S	B140	3	55	60	40	0	0	413								
	225M	B140	3	55	60	40	0	0	413								
	250M ³⁾	B160	4	60	65	40	10	23	447								

Motor connection

Motor bell housing for IEC motors

Type H3, gear unit sizes 505 to 514
with N-EUPEX coupling

Design (continued)

Gear unit sizes	Dimensions in mm																
	Basic dimensions					Ratio range 1				Ratio range 2				Ratio range 3			
	IEC motor ¹⁾	N-EUPEX	S _k	NL	D ₂	D ₁	h ₁	h ₂	f	D ₁	h ₁	h ₂	f	D ₁	h ₁	h ₂	f
507						$i_N = 20 - 40$				$i_N = 45 - 56$				$i_N = 63 - 71$			
508						$i_N = 25 - 50$				$i_N = 56 - 71$				$i_N = 80 - 90$			
	160M	B110	3	40	42									28	5	7.5	405.5
	160L	B110	3	40	42									28	5	7.5	405.5
	180M	B110	3	40	48					35	0	2.5	405.5	28	2	10.5	405.5
	180L	B125	3	50	48					35	0	2.5	405.5	28	6	6.5	405.5
	200L	B140	3	55	55	45	0	2.5	425.5	35	7	15.5	425.5	28	0	2.5	395.5
	225S	B140	3	55	60	45	7	13.5	473.5	35	7	9.5	449.5	28	0	4.5	427.5
	225M	B140	3	55	60	45	7	13.5	473.5	35	7	9.5	449.5	28	0	4.5	427.5
	250M	B160	4	60	65	45	3	4.5	461.5	35	8	19.5	461.5				
	280S	B180	4	70	75	45	3	4.5	461.5								
	280M	B180	4	70	75	45	3	4.5	461.5								
509						$i_N = 20 - 40$				$i_N = 45 - 56$				$i_N = 63 - 71$			
510						$i_N = 25 - 50$				$i_N = 56 - 71$				$i_N = 80 - 90$			
	225S	B140	3	55	60	60	0	1	524	45	0	2	500	32	0	0	478
	225M	B140	3	55	60	60	0	1	524	45	0	2	500	32	0	0	478
	250M	B160	4	60	65	60	8	10	542	45	6	7	512				
		B180	4	70	65									32	10	23	512
	280S	B180	4	70	75	60	8	10	542	45	6	7	512				
	280M	B180	4	70	75	60	8	10	542	45	6	7	512				
	315S ³⁾	B200	4	80	80	60	12	22	588								
	315M ³⁾	B200	4	80	80	60	12	22	588								
	315L ^{2) 3)}	B225	4	90	80	60	17	17	588								
511						$i_N = 20 - 40$				$i_N = 45 - 56$				$i_N = 63 - 71$			
512						$i_N = 25 - 50$				$i_N = 56 - 71$				$i_N = 80 - 90$			
	225S	B140	3	55	60									48	4	5	537
	225M	B140	3	55	60									48	4	5	537
	250M	B160	4	60	65					50	8	12	549	48	8	12	549
	280S	B180	4	70	75	70	10	15	579	50	8	12	549	48	8	12	549
	280M	B180	4	70	75	70	10	15	579	50	8	12	549	48	8	12	549
	315S	B200	4	80	80	70	15	26	625	50	0	21	580	48	0	21	580
	315M	B200	4	80	80	70	15	26	625	50	0	21	580	48	0	21	580
	315L ²⁾	B225	4	90	80	70	18	23	625								
513						$i_N = 20 - 40$				$i_N = 45 - 56$				$i_N = 63 - 71$			
514						$i_N = 25 - 50$				$i_N = 56 - 71$				$i_N = 80 - 90$			
	280M	B180	4	70	75									50	4	4.5	582.5
	315S	B200	4	80	80	85	2	2.5	658.5	65	10	14.5	658.5	50	0	9.5	613.5
	315M	B200	4	80	80	85	2	2.5	658.5	65	10	14.5	658.5	50	0	9.5	613.5
	315L ²⁾	B225	4	90	80	85	2	2.5	658.5	65	10	14.5	658.5				
	315 ⁴⁾	On request				85	On request										

¹⁾ Other motor sizes on request.

²⁾ Siemens designation (size not included in DIN EN 50347)

³⁾ Notice: Motor flange radius $\varnothing P/2$ is greater than gear unit axis height h!

⁴⁾ Siemens designation non-standard motor (corresponds to LOHER designation 355M/L)

Motor connection

Motor bell housing for IEC motors

Type H4, gear unit sizes 507 to 514
with N-EUPEX coupling

Design

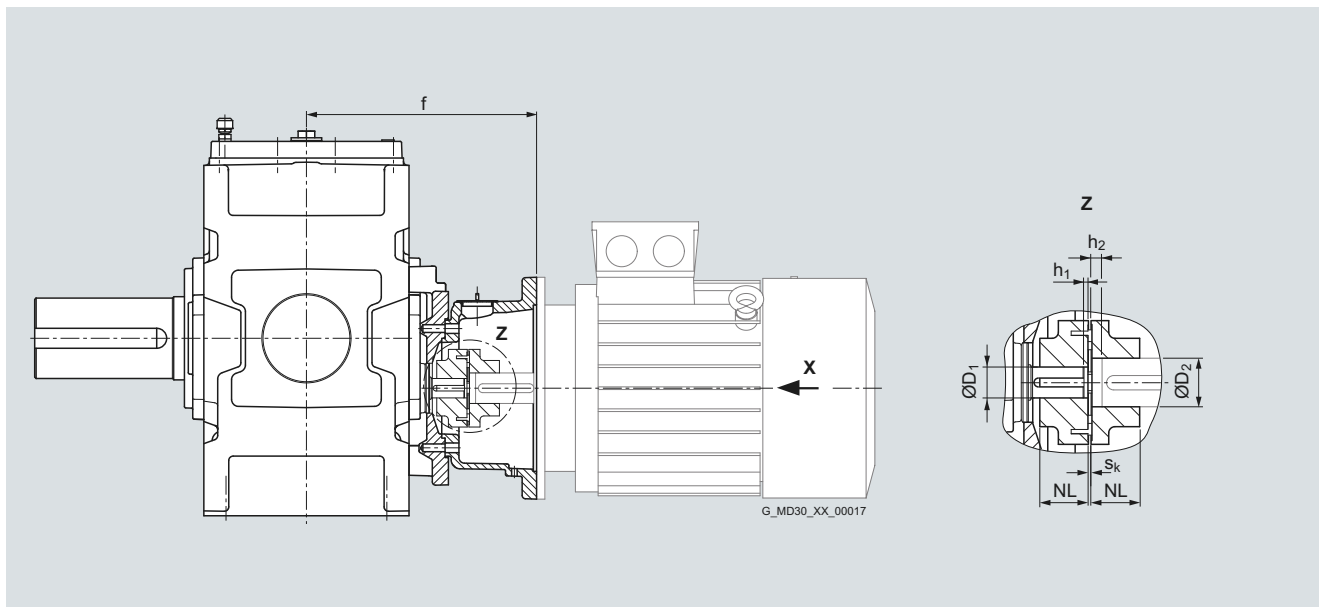

- For plants with special design requirements (high switching frequency, alternating direction of load; e.g. hoisting gears, traveling gears, etc.) the coupling design is to be checked in accordance with the respective valid coupling brochure. For other couplings, please consult us.
- For fitting dimensions for IEC standard motors DIN EN 50347 (View X), see page 8/12.
- Not in connection with taconite E on input shaft (see note on page 7/2).

Gear unit sizes	Dimensions in mm																
	Basic dimensions					Ratio range 1				Ratio range 2				Ratio range 3			
	IEC motor 1)	N-EUPEX	S _k	NL	D ₂	D ₁	h ₁	h ₂	f	D ₁	h ₁	h ₂	f	D ₁	h ₁	h ₂	f
507						<i>i_N</i> = 80 - 140				<i>i_N</i> = 160 - 280							
508						<i>i_N</i> = 100 - 180				<i>i_N</i> = 200 - 355							
	112M	B080	3	30	28					28	0	0	328				
	132S	B095	3	35	38	35	0	0	358	28	0	10	358				
	132M	B095	3	35	38	35	0	0	358	28	0	10	358				
	160M	B095	3	35	42	35	0	0	388	28	4	6	388				
	160L	B110	3	40	42	35	0	0	388	28	2	8	388				
	180M	B110	3	40	48	35	0	0	388	28	2	8	388				
	180L	B125	3	50	48	35	0	0	388	28	5	5	388				
	200L	B140	3	55	55	35	7	13	408								
509						<i>i_N</i> = 80 - 160				<i>i_N</i> = 180 - 315							
510						<i>i_N</i> = 100 - 200				<i>i_N</i> = 224 - 400							
	160M	B095	3	35	42	35	0	0	398	28	4	6	398				
	160L	B110	3	40	42	35	0	0	398	28	2	8	398				
	180M	B110	3	40	48	35	0	0	398	28	2	8	398				
	180L	B125	3	50	48	35	0	0	398	28	5	5	398				
	200L	B140	3	55	55	35	7	10	415	28	7	20	415				
	225S	B140	3	55	60	35	7	12	447								
	225M	B140	3	55	60	35	7	12	447								

Motor connection

Motor bell housing for IEC motors

Type H4, gear unit sizes 507 to 514
with N-EUPEX coupling

Design (continued)

Gear unit sizes	Dimensions in mm					Ratio range 1				Ratio range 2				Ratio range 3			
	Basic dimensions					D ₁	h ₁	h ₂	f	D ₁	h ₁	h ₂	f	D ₁	h ₁	h ₂	f
	IEC motor ¹⁾	N-EUPEX	S _k	NL	D ₂	$i_N = 80 - 160$				$i_N = 180 - 224$				$i_N = 250 - 315$			
						$i_N = 100 - 200$				$i_N = 224 - 280$				$i_N = 315 - 400$			
511	160M	B110	3	40	42					35	2	8	458				
		B125	3	50	42									28	6	14	458
	160L	B110	3	40	42					35	2	8	458				
		B125	3	50	42									28	6	14	458
	180M	B110	3	40	48					35	2	8	458	28	8	12	458
	180L	B125	3	50	48					35	5	5	458	28	6	14	458
	200L	B140	3	55	55	45	5	5	478	35	0	0	448	28	5	5	448
	225S	B140	3	55	60	45	2	2	502	35	0	2	480	28	0	12	480
	225M	B140	3	55	60	45	2	2	502	35	0	2	480	28	0	12	480
	250M	B160	4	60	65	45	7	8	514								
	280S	B180	4	70	75	45	7	8	514								
	280M	B180	4	70	75	45	7	8	514								
513						$i_N = 80 - 160$				$i_N = 180 - 224$				$i_N = 250 - 315$			
						$i_N = 100 - 200$				$i_N = 224 - 280$				$i_N = 315 - 400$			
514	225S	B140	3	55	60					45	7	15.5	570.5	32	7	11.5	546.5
	225M	B140	3	55	60					45	7	15.5	570.5	32	7	11.5	546.5
	250M	B160	4	60	65	60	7	7.5	588.5	45	4	5.5	558.5	32	6.5	23	558.5
	280S	B180	4	70	75	60	7	7.5	588.5	45	4	5.5	558.5				
	280M	B180	4	70	75	60	7	7.5	588.5	45	4	5.5	558.5				
	315S	B200	4	80	80	60	12	18.5	634.5								
	315M	B200	4	80	80	60	12	18.5	634.5								

¹⁾ Other motor sizes on request.

Motor connection

Motor bell housing for IEC motors

Type B3, gear unit sizes 504 to 514 with N-EUPEX coupling

Design

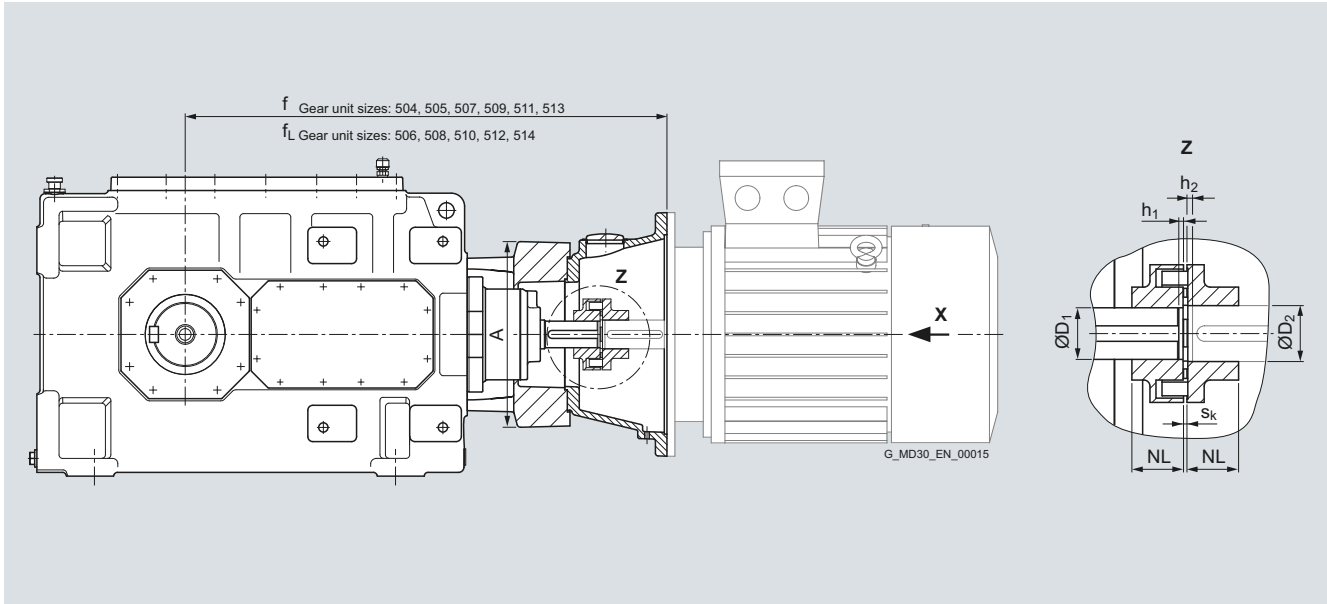

- For plants with special design requirements (high switching frequency, alternating direction of load; e.g. hoisting gears, traveling gears, etc.) the coupling design is to be checked in accordance with the respective valid coupling brochure. For other couplings, please consult us.
- For fitting dimensions for IEC standard motors DIN EN 50347 (View X), see page 8/12.
- Not in connection with taconite E on input shaft (see note on page 7/2).

Gear unit sizes	Dimensions in mm															
	Basic dimensions						Ratio range 1					Ratio range 2				
	IEC motor ¹⁾	N-EUPEX	S _k	NL	D ₂	A	D ₁	h ₁	h ₂	f	f _L	D ₁	h ₁	h ₂	f	f _L
504										<i>i_N = 14 - 56</i>					<i>i_N = 63</i>	
	132S	B095	3	35	38	Ø 250	35	0	0	663	—	32	0	10	663	—
	132M	B095	3	35	38	Ø 250	35	0	0	663	—	32	0	10	663	—
	160M	B095	3	35	42	Ø 250	35	0	0	693	—					
		B110	3	40	42	Ø 250						32	2	8	693	—
	160L	B110	3	40	42	Ø 250	35	0	0	693	—	32	2	8	693	—
	180M	B110	3	40	48	Ø 250	35	0	0	693	—					
	180L	B125	3	50	48	Ø 250	35	0	0	693	—					
	200L	B140	3	55	55	Ø 250	35	7	13	713	—					
505										<i>i_N = 14 - 50</i>					<i>i_N = 56</i>	
506										<i>i_N = 20 - 71</i>					<i>i_N = 80</i>	
	160M	B095	3	35	42	□ 315	40	0	0	778	831	35	4	6	778	831
	160L	B110	3	40	42	□ 315	40	0	0	778	831	35	3	7	778	831
	180M	B110	3	40	48	□ 315	40	0	0	778	831	35	2	8	778	831
	180L	B125	3	50	48	□ 315	40	0	0	778	831	35	5	5	778	831
	200L	B140	3	55	55	□ 315	40	7	13	798	851	35	0	0	768	821
	225S	B140	3	55	60	□ 315	40	7	7	822	875					
	225M	B140	3	55	60	□ 315	40	7	7	822	875					
	250M ³⁾	B160	4	60	65	□ 315	40	8	17	834	887					
	280S ³⁾	B180	4	70	75	□ 315	40	10	15	834	887					
	280M ³⁾	B180	4	70	75	□ 315	40	10	15	834	887					

8

Motor connection

Motor bell housing for IEC motors

Type B3, gear unit sizes 504 to 514
with N-EUPEX coupling

Design (continued)

Gear unit sizes	Dimensions in mm															
	Basic dimensions						Ratio range 1					Ratio range 2				
	IEC motor ¹⁾	N-EUPEX	S _k	NL	D ₂	A	D ₁	h ₁	h ₂	f	f _L	D ₁	h ₁	h ₂	f	f _L
507							<i>i_N</i> = 14 - 50					<i>i_N</i> = 56				
508							<i>i_N</i> = 18 - 63					<i>i_N</i> = 71				
	160M	B110	3	40	42	□ 315						40	12	8	913	960
	160L	B110	3	40	42	□ 315						40	12	8	913	960
	180M	B110	3	40	48	□ 315						40	8	12	913	960
	180L	B125	3	50	48	□ 315						40	6	14	913	960
	200L	B140	3	55	55	□ 315	50	7	13	933	980	40	5	5	903	950
	225S	B140	3	55	60	□ 315	50	7	7	957	1004	40	6	6	935	982
	225M	B140	3	55	60	□ 315	50	7	7	957	1004	40	6	6	935	982
	250M	B160	4	60	65	□ 315	50	8	17	969	1016					
	280S	B180	4	70	75	□ 315	50	10	15	969	1016					
	280M	B180	4	70	75	□ 315	50	10	15	969	1016					
509							<i>i_N</i> = 14 - 50					<i>i_N</i> = 56				
510							<i>i_N</i> = 18 - 63					<i>i_N</i> = 71				
	225S	B140	3	55	60	□ 420	60	7	7	1089	1142	50	0	0	1065	1118
	225M	B140	3	55	60	□ 420	60	7	7	1089	1142	50	0	0	1065	1118
	250M	B160	4	60	65	□ 420	60	0	1	1077	1130	50	5	6	1077	1130
	280S	B180	4	70	75	□ 420	60	0	1	1077	1130	50	5	6	1077	1130
	280M	B180	4	70	75	□ 420	60	0	1	1077	1130	50	5	6	1077	1130
	315S ³⁾	B200	4	80	80	□ 420	60	0	2	1108	1161					
	315M ³⁾	B200	4	80	80	□ 420	60	0	2	1108	1161					
511							<i>i_N</i> = 14 - 50					<i>i_N</i> = 56				
512							<i>i_N</i> = 18 - 63					<i>i_N</i> = 71				
	225S	B140	3	55	60	□ 420						60	6	7	1266	1324
	225M	B140	3	55	60	□ 420						60	6	7	1266	1324
	250M	B160	4	60	65	□ 420						60	0	0	1254	1312
	280S	B180	4	70	75	□ 420	75	0	0	1254	1312	60	0	0	1254	1312
	280M	B180	4	70	75	□ 420	75	0	0	1254	1312	60	0	0	1254	1312
	315S	B200	4	80	80	□ 420	75	0	1	1285	1343	60	0	1	1285	1343
	315M	B200	4	80	80	□ 420	75	0	1	1285	1343	60	0	1	1285	1343
513							<i>i_N</i> = 14 - 40					<i>i_N</i> = 45 - 56				
514							<i>i_N</i> = 18 - 50					<i>i_N</i> = 56 - 71				
	315S	B200	4	80	80	□ 420	80	10	10	1526	1604	70	0	0	1486	1564
	315M	B200	4	80	80	□ 420	80	10	10	1526	1604	70	0	0	1486	1564
	315L ²⁾	B225	4	90	80	□ 420	80	10	10	1526	1604	70	0	0	1486	1564

¹⁾ Other motor sizes on request.

²⁾ Siemens designation (size not included in DIN EN 50347)

³⁾ Notice: Motor flange radius ØP/2 is greater than gear unit axis height h!

Motor connection

Motor bell housing for IEC motors

Type B4, gear unit sizes 505 to 514 with N-EUPEX coupling

Design

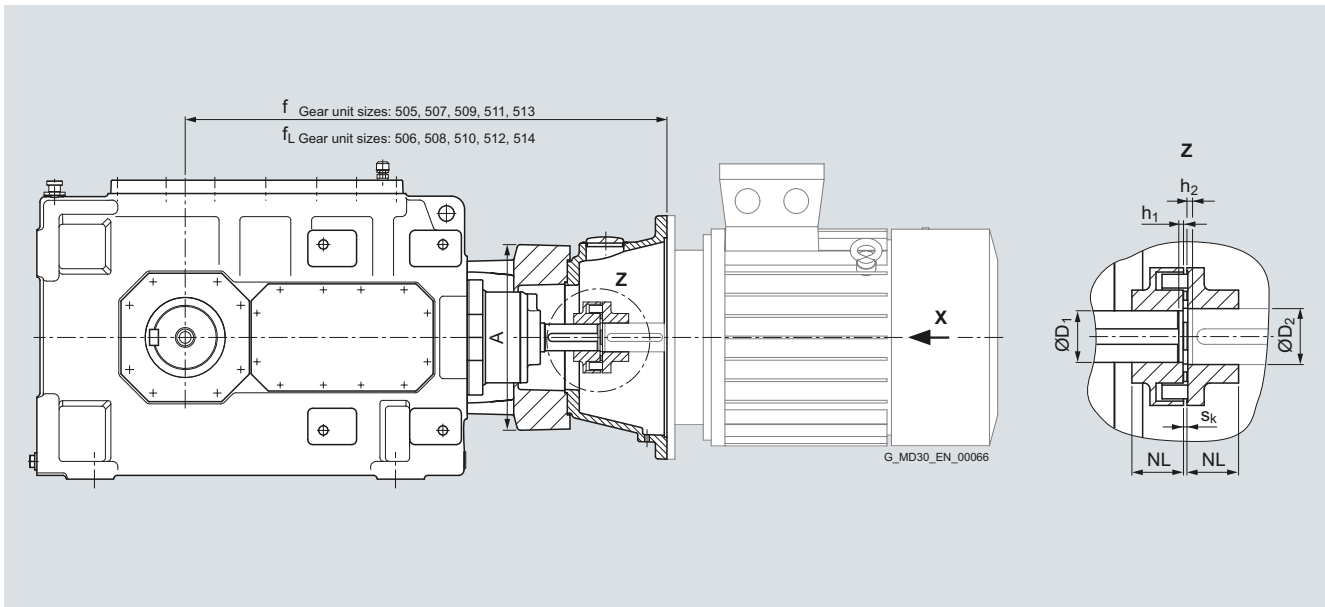

- For plants with special design requirements (high switching frequency, alternating direction of load; e.g. hoisting gears, traveling gears, etc.) the coupling design is to be checked in accordance with the respective valid coupling brochure. For other couplings, please consult us.
- For fitting dimensions for IEC standard motors DIN EN 50347 (View X), see page 8/12.
- Not in connection with taconite E on input shaft (see note on page 7/2).

Gear unit sizes	Dimensions in mm																
	Basic dimensions						Ratio range 1					Ratio range 2					
	IEC motor 1)	N-EUPEX	S _k	NL	D ₂	A	D ₁	h ₁	h ₂	f	f _L	D ₁	h ₁	h ₂	f	f _L	
505										i _N = 63 - 200					i _N = 224 - 280		
506											i _N = 90 - 280					i _N = 315 - 355	
	100L	B068	3	20	28	Ø 250							20	0	0	723	776
	112M	B068	3	20	28	Ø 250							20	0	0	723	776
		B080	3	30	28	Ø 250	28	0	0	728	781						
	132S	B080	3	30	38	Ø 250	28	0	3	751	804	20	0	8	751	804	
	132M	B095	3	35	38	Ø 250	28	0	3	751	804	20	0	8	751	804	
	160M	B095	3	35	42	Ø 250	28	0	3	781	834	20	2	6	781	834	
	160L	B110	3	40	42	Ø 250	28	0	3	781	834	20	2	6	781	834	
	180M	B110	3	40	48	Ø 250	28	0	3	781	834						
	180L	B125	3	50	48	Ø 250	28	0	3	781	834						

Motor connection

Motor bell housing for IEC motors

Type B4, gear unit sizes 505 to 514
with N-EUPEX coupling

Design (continued)

Gear unit sizes	Dimensions in mm															
	Basic dimensions						Ratio range 1					Ratio range 2				
	IEC motor 1)	N-EUPEX	S _k	NL	D ₂	A	D ₁	h ₁	h ₂	f	f _L	D ₁	h ₁	h ₂	f	f _L
507							<i>i_N</i> = 63 - 200					<i>i_N</i> = 224				
508							<i>i_N</i> = 80 - 250					<i>i_N</i> = 280				
	132S	B095	3	35	38	∅ 250	35	0	0	887	934	32	0	10	887	934
	132M	B095	3	35	38	∅ 250	35	0	0	887	934	32	0	10	887	934
	160M	B095	3	35	42	∅ 250	35	0	0	917	964					
		B110	3	40	42	∅ 250						32	2	8	917	964
	160L	B110	3	40	42	∅ 250	35	0	0	917	964	32	2	8	917	964
		B125	3	50	42	∅ 250										
	180M	B110	3	40	48	∅ 250	35	0	0	917	964					
	180L	B125	3	50	48	∅ 250	35	0	0	917	964					
	200L	B140	3	55	55	∅ 250	35	7	13	937	984					
507							<i>i_N</i> = 250 - 280									
508							<i>i_N</i> = 315 - 355									
	132S	B095	3	35	38	∅ 250						25	9	11	887	934
	132M	B095	3	35	38	∅ 250						25	9	11	887	934
	160M	B110	3	40	42	∅ 250						25	12	8	917	964
	160L	B125	3	50	42	∅ 250						25	6	14	917	964
509							<i>i_N</i> = 63 - 200					<i>i_N</i> = 224 - 280				
510							<i>i_N</i> = 80 - 250					<i>i_N</i> = 280 - 355				
	160M	B095	3	35	42	□ 315	40	0	0	1043	1096	35	4	6	1043	1096
	160L	B110	3	40	42	□ 315	40	0	0	1043	1096	35	3	7	1043	1096
	180M	B110	3	40	48	□ 315	40	0	0	1043	1096	35	2	8	1043	1096
	180L	B125	3	50	48	□ 315	40	0	0	1043	1096	35	5	5	1043	1096
	200L	B140	3	55	55	□ 315	40	7	13	1063	1116					
	225S	B140	3	55	60	□ 315	40	7	7	1087	1140					
	225M	B140	3	55	60	□ 315	40	7	7	1087	1140					
	250M	B160	4	60	65	□ 315	40	8	17	1099	1152					
511							<i>i_N</i> = 63 - 200					<i>i_N</i> = 224 - 280				
512							<i>i_N</i> = 80 - 250					<i>i_N</i> = 280 - 355				
	160M	B110	3	40	42	□ 315						40	12	8	1235	1293
	160L	B110	3	40	42	□ 315						40	12	8	1235	1293
	180M	B110	3	40	48	□ 315						40	8	12	1235	1293
		B125	3	50	48	□ 315	50	0	0	1235	1293					
	180L	B125	3	50	48	□ 315	50	0	0	1235	1293	40	6	14	1235	1293
	200L	B140	3	55	55	□ 315	50	7	13	1255	1313	40	5	5	1225	1283
	225S	B140	3	55	60	□ 315	50	7	7	1279	1337	40	6	6	1257	1315
	225M	B140	3	55	60	□ 315	50	7	7	1279	1337	40	6	6	1257	1315
	250M	B160	4	60	65	□ 315	50	8	17	1291	1349					
	280S	B180	4	70	75	□ 315	50	10	15	1291	1349					
	280M	B180	4	70	75	□ 315	50	10	15	1291	1349					
513							<i>i_N</i> = 63 - 200					<i>i_N</i> = 224 - 280				
514							<i>i_N</i> = 80 - 250					<i>i_N</i> = 280 - 355				
	225S	B140	3	55	60	□ 420	60	7	7	1467	1545	50	0	0	1443	1521
	225M	B140	3	55	60	□ 420	60	7	7	1467	1545	50	0	0	1443	1521
	250M	B160	4	60	65	□ 420	60	0	1	1455	1533	50	5	6	1455	1533
	280S	B180	4	70	75	□ 420	60	0	1	1455	1533	50	5	6	1455	1533
	280M	B180	4	70	75	□ 420	60	0	1	1455	1533	50	5	6	1455	1533
	315S	B200	4	80	80	□ 420	60	0	2	1486	1564					
	315M	B200	4	80	80	□ 420	60	0	2	1486	1564					

1) Other motor sizes on request.

Motor connection

Motor bell housing for IEC motors

Fitting dimensions for IEC motors

Design

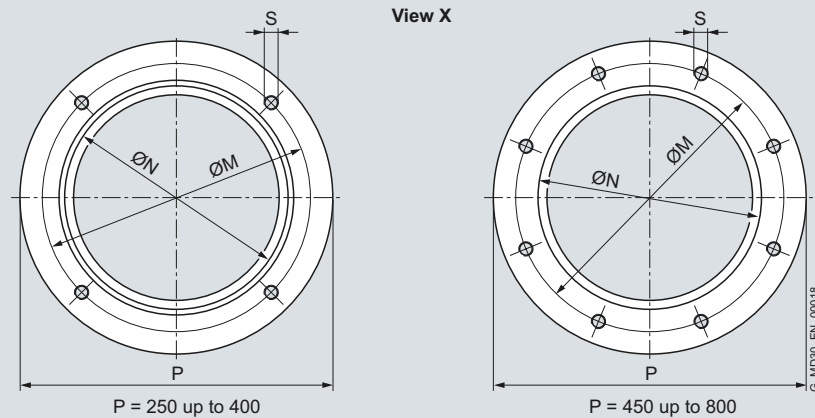

Flange dimensions

For three-phase motors with squirrel-cage rotor acc. to DIN EN 50347

		Motor frame sizes											
		100L	112M	132S 132M	160M 160L	180M 180L	200L	225S 225M	250M	280S 280M	315S 315M	315L ¹⁾	315 ²⁾
Max. power rating P_N at 50 Hz	kW	3	4	7.5	15	22	30	45	55	90	132	200	315
$\varnothing P$	mm	250	250	300	350	350	400	450	550	550	660	660	800
$\varnothing N$ (H7)	mm	180	180	230	250	250	300	350	450	450	550	550	680
$\varnothing M$	mm	215	215	265	300	300	350	400	500	500	600	600	740
S		4 x M12			4 x M16			8 x M16			8 x M20		

¹⁾ Siemens designation (not included in DIN EN 50347)

²⁾ Siemens designation non-standard motor (corresponds to LOHER designation 355M/L)

Appendix



9/2	Partner at Industry Automation and Drive Technologies
9/3	Online Services
9/3	Information and Ordering in the Internet and on DVD
9/4	Service & Support
9/4	The unmatched complete service for the entire life cycle
9/7	Subject index
9/8	Conditions of sale and delivery Export regulations

Appendix

Partner at Industry Automation and Drive Technologies



At Siemens Industry Automation and Drive Technologies, more than 85 000 people are resolutely pursuing the same goal: long-term improvement of your competitive ability. We are committed to this goal. Thanks to our commitment, we continue to set new standards in automation and drive technology. In all industries – worldwide.

At your service locally, around the globe for consulting, sales, training, service, support, spare parts ... on the entire Industry Automation and Drive Technologies range.

Your personal contact can be found in our Contacts Database at: www.siemens.com/automation/partner

You start by selecting a

- Product group,
- Country,
- City,
- Service.

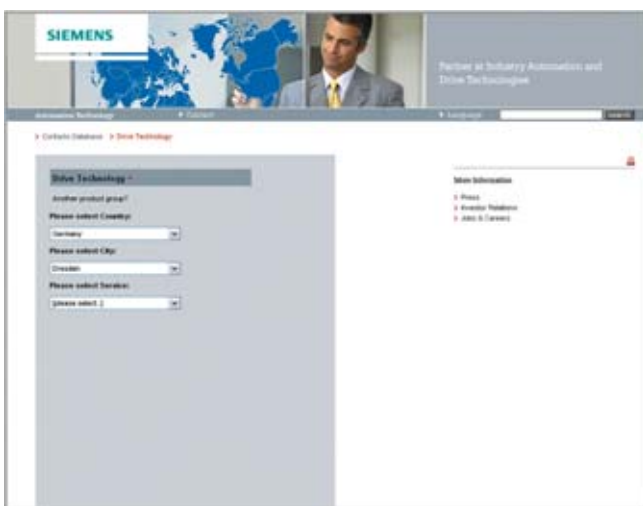

Siemens Industry Automation and Drive Technologies in the WWW

A detailed knowledge of the range of products and services available is essential when planning and configuring automation systems. It goes without saying that this information must always be fully up-to-date.

Siemens Industry Automation and Drive Technologies has therefore built up a comprehensive range of information in the World Wide Web, which offers quick and easy access to all data required.

Under the address

www.siemens.com/industry

you will find everything you need to know about products, systems and services.

Product Selection Using the Interactive Catalog CA 01 of Industry

Detailed information together with convenient interactive functions:

The interactive catalog CA 01 covers more than 80 000 products and thus provides a full summary of the Siemens Industry Automation and Drive Technologies product base.

Here you will find everything that you need to solve tasks in the fields of automation, switchgear, installation and drives. All information is linked into a user interface which is easy to work with and intuitive.

After selecting the product of your choice you can order at the press of a button, by fax or by online link.

Information on the interactive catalog CA 01 can be found in the Internet under

www.siemens.com/automation/ca01

or on DVD.

Easy Shopping with the Industry Mall

The Industry Mall is the virtual department store of Siemens AG in the Internet. Here you have access to a huge range of products presented in electronic catalogs in an informative and attractive way.

Data transfer via EDIFACT allows the whole procedure from selection through ordering to tracking of the order to be carried out online via the Internet.

Numerous functions are available to support you.

For example, powerful search functions make it easy to find the required products, which can be immediately checked for availability. Customer-specific discounts and preparation of quotes can be carried out online as well as order tracking and tracing.

Please visit the Industry Mall on the Internet under:

www.siemens.com/industrymall

Appendix Service & Support

The unmatched complete service for the entire life cycle

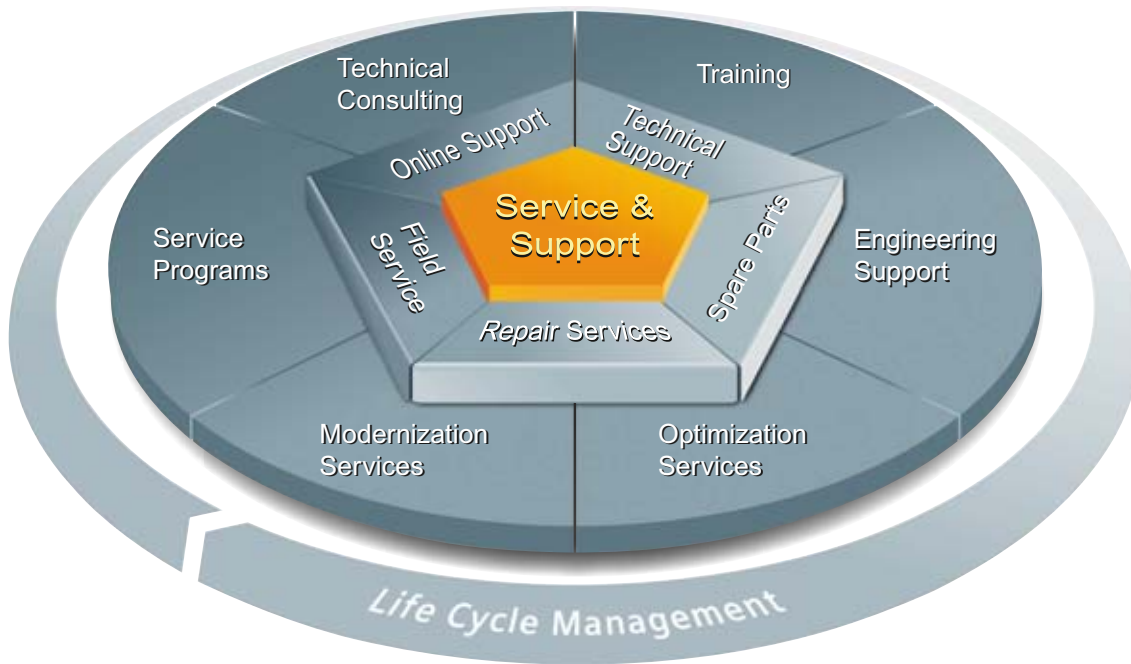

For machine constructors, solution providers and plant operators: The service offering from Siemens Industry, Automation and Drive Technologies includes comprehensive services for a wide range of different users in all sectors of the manufacturing and process industry

To accompany our products and systems, we offer integrated and structured services that provide valuable support in every phase of the life cycle of your machine or plant - from planning and implementation through commissioning as far as maintenance and modernization.

Our Service & Support accompanies you worldwide in all matters concerning automation and drives from Siemens. We provide direct on-site support in more than 100 countries through all phases of the life cycle of your machines and plants.

You have an experienced team of specialists at your side to provide active support and bundled know-how. Regular training courses and intensive contact among our employees - even across continents - ensure reliable service in the most diverse areas.

Online Support



The comprehensive online information platform supports you in all aspects of our Service & Support at any time and from any location in the world.

www.siemens.com/automation/service&support

Technical Consulting



Support in planning and designing your project: From detailed actual-state analysis, definition of the goal and consulting on product and system questions right through to the creation of the automation solution.

Technical Support



Expert advice on technical questions with a wide range of demand-optimized services for all our products and systems.

www.siemens.com/automation/support-request

Training



Extend your competitive edge - through practical know-how directly from the manufacturer.

www.siemens.com/sitrain

Contact information is available in the Internet at:
www.siemens.com/automation/partner

9

The unmatched complete service
for the entire life cycle

Engineering Support



Support during project engineering and development with services fine-tuned to your requirements, from configuration through to implementation of an automation project.

Modernization



You can also rely on our support when it comes to modernization - with comprehensive services from the planning phase all the way to commissioning.

Field Service



Our Field Service offers you services for commissioning and maintenance - to ensure that your machines and plants are always available.

Service programs



Our service programs are selected service packages for an automation and drives system or product group. The individual services are coordinated with each other to ensure smooth coverage of the entire life cycle and support optimum use of your products and systems.

The services of a Service Program can be flexibly adapted at any time and used separately.

Spare parts



In every sector worldwide, plants and systems are required to operate with constantly increasing reliability. We will provide you with the support you need to prevent a standstill from occurring in the first place: with a worldwide network and optimum logistics chains.

Examples of service programs:

- Service contracts
- Plant IT Security Services
- Life Cycle Services for Drive Engineering
- SIMATIC PCS 7 Life Cycle Services
- SINUMERIK Manufacturing Excellence
- SIMATIC Remote Support Services

Advantages at a glance:

- Reduced downtimes for increased productivity
- Optimized maintenance costs due to a tailored scope of services
- Costs that can be calculated and therefore planned
- Service reliability due to guaranteed response times and spare part delivery times
- Customer service personnel will be supported and relieved of additional tasks
- Comprehensive service from a single source, fewer interfaces and greater expertise

Repairs



Downtimes cause problems in the plant as well as unnecessary costs. We can help you to reduce both to a minimum - with our worldwide repair facilities.

Optimization



During the service life of machines and plants, there is often a great potential for increasing productivity or reducing costs. To help you achieve this potential, we are offering a complete range of optimization services.

Contact information is available in the Internet at:
www.siemens.com/automation/partner

Appendix

Service & Support

Knowledge Base on DVD



For locations without online connections to the Internet there are excerpts of the free part of the information sources available on DVD (Service & Support Knowledge Base). This DVD contains all the latest product information at the time of production (FAQs, Downloads, Tips and Tricks, Updates) as well as general information on Service & Support.

The DVD also includes a full-text search and our Knowledge Manager for targeted searches for solutions. The DVD will be updated every 4 months.

Just the same as our online offer in the Internet, the Service & Support Knowledge Base on DVD comes complete in 5 languages (German, English, French, Italian, Spanish).

You can order the **Service & Support Knowledge Base** DVD from your Siemens contact.

Order no. **6ZB5310-0EP30-0BA2**

Automation Value Card



Small card - great support

The Automation Value Card is an integral component of the comprehensive service concept with which Siemens Automation and Drives will accompany you in each phase of your automation project.

It doesn't matter whether you want just specific services from our Technical Support or want to purchase something on our Online portal, you can always pay with your Automation Value Card. No invoicing, transparent and safe. With your personal card number and associated PIN you can view the state of your account and all transactions at any time.

Services on card. This is how it's done.

Card number and PIN are on the back of the Automation Value Card. When delivered, the PIN is covered by a scratch field, guaranteeing that the full credit is on the card.

By entering the card number and PIN you have full access to the Service & Support services being offered. The charge for the services procured is debited from the credits on your Automation Value Card.

All the services offered are marked in currency-neutral credits, so you can use the Automation Value Card worldwide.

Order your Automation and Value Card easily and comfortably like a product with your sales contact.

Automation Value Card order numbers

Credits	Order no.
200	6ES7 997-0BA00-0XA0
500	6ES7 997-0BB00-0XA0
1 000	6ES7 997-0BC00-0XA0
10 000	6ES7 997-0BG00-0XA0

Detailed information on the services offered is available on our Internet site at:

www.siemens.com/automation/service&support

Service & Support à la Card: Examples

Technical Support

"Priority"	Priority processing for urgent cases
"24 h"	Availability round the clock
"Extended"	Technical consulting for complex questions
"Mature Products"	Consulting service for products that are not available any more

Support Tools in the Support Shop

Tools that can be used directly for configuration, analysis and testing

I IA/DT/BT Standard-Anhang En 09.02.2011

A	
Actual ratio	
• Type H2, H3, H4	3/36
• Type B3, B4	3/37
C	
Central holes, form DS in shaft ends DIN 332/1	6/2
Characteristic features	1/3
Connection dimensions	6
Cooling coil	7/3
Cooling	7/3
• Fan	7/3
• Cooling coil	7/3
Cylindrical shaft ends	6/2
E	
Explanation of symbols used in the dimensioned drawings	1/3
F	
Fan	7/3
Fitting dimensions for IEC Motors	8/12
G	
Gear unit dimensions	
• Type H2	4/2
• Type H3	4/6
• Type H4	4/10
• Type B3	5/2
• Type B4	5/6
Guidelines for selection of the gear units	
• Constant mechanical power rating	3/2
• Variable power rating	3/4
• Calculation example	3/6
• Service factors	3/8
H	
Helical gear units horizontal mounting position	4/1
Hollow shaft with keyway to DIN 6885/1	6/6
Hollow shafts for shrink disk	6/5
K	
Key to symbols	3/5
M	
Maintenance	2/2
Motor connection	8
• Type H2	8/2
• Type H3	8/4
• Type H4	8/6
• Type B3	8/8
• Type B4	8/10
N	
N-EUPEX coupling	
• Type H2	8/2
• Type H3	8/4
• Type H4	8/6
• Type B3	8/8
Nominal output torques	
• Type H2	3/11
• Type H3	3/17
• Type H4	3/23
• Type B3	3/27
• Type B4	3/33
Nominal power ratings	
• Type H2	3/10
• Type H3	3/16
• Type H4	3/22
• Type B3	3/26
• Type B4	3/32
• Type B4	8/10
Notes and legend for tables of thermal capacities	3/5
Notes on selection and operation	1/3
O	
Options for operation	7
Order number overview	
• Type H2, H3, H4	4/14
• Type B3, B4	5/10
P	
Parallel keys, parallel keyways and hollow shafts with keyway	6/4
Preservation	2/2
S	
Selection and ordering data	
• Type H2, H3, H4	4/14
• Type B3, B4	5/10
Selection of fit	6/3
Selection of oil	2/2
Shaft misalignment	2/2
Shaft seals	7/2
• Radial shaft seals	7/2
• Taconite	7/2
Summary of basic types	
• Horizontal mounting position	1/2
• Structure of types	1/2
• Structure of gear unit size	1/2
T	
Taconite	7/2
Thermal capacities	
• Type H2	3/12
• Type H3	3/18
• Type H4	3/24
• Type B3	3/28
• Type B4	3/34

Appendix

Conditions of sale and delivery, Export regulations

Terms and Conditions of Sale and Delivery

By using this catalog you can acquire hardware and software products described therein from Siemens AG subject to the following terms. Please note! The scope, the quality and the conditions for supplies and services, including software products, by any Siemens entity having a registered office outside of Germany, shall be subject exclusively to the General Terms and Conditions of the respective Siemens entity. The following terms apply exclusively for orders placed with Siemens AG.

For customers with a seat or registered office in Germany

The "General Terms of Payment" as well as the "General Conditions for the Supply of Products and Services of the Electrical and Electronics Industry" shall apply.

For software products, the "General License Conditions for Software Products for Automation and Drives for Customers with a Seat or registered Office in Germany" shall apply.

For customers with a seat or registered office outside of Germany

The "General Terms of Payment" as well as the "General Conditions for Supplies of Siemens Automation and Drives for Customers with a Seat or registered Office outside of Germany" shall apply.

For software products, the "General License Conditions for Software Products for Automation and Drives for Customers with a Seat or registered Office outside of Germany" shall apply.

General

The dimensions are in mm. In Germany, according to the German law on units in measuring technology, data in inches only apply to devices for export.

Illustrations are not binding.

Insofar as there are no remarks on the corresponding pages, - especially with regard to data, dimensions and weights given - these are subject to change without prior notice.

The prices are in € (Euro) ex works, exclusive packaging.

The sales tax (value added tax) is not included in the prices. It shall be debited separately at the respective rate according to the applicable legal regulations.

Prices are subject to change without prior notice. We will debit the prices valid at the time of delivery.

Surcharges will be added to the prices of products that contain silver, copper, aluminum, lead and/or gold if the respective basic official prices for these metals are exceeded. These surcharges will be determined based on the official price and the metal factor of the respective product.

The surcharge will be calculated on the basis of the official price on the day prior to receipt of the order or prior to the release order.

The metal factor determines the official price as of which the metal surcharges are charged and the calculation method used. The metal factor, provided it is relevant, is included with the price information of the respective products.

An exact explanation of the metal factor and the text of the Comprehensive Terms and Conditions of Sale and Delivery are available free of charge from your local Siemens business office under the following Order Nos.:

- 6ZB5310-0KR30-0BA1
(for customers based in Germany)
- 6ZB5310-0KS53-0BA1
(for customers based outside Germany)

or download them from the Internet
www.siemens.com/industrymall
(Germany: Industry Mall Online-Help System)

Export regulations

Our obligation to fulfill this agreement is subject to the proviso that the fulfillment is not prevented by any impediments arising out of national and international foreign trade and customs requirements or any embargos and/or other sanctions.

If you transfer goods (hardware and/ or software and/ or technology as well as corresponding documentation, regardless of the mode of provision) delivered by us or works and services (including all kinds of technical support) performed by us to a third party worldwide, you shall comply with all applicable national and international (re-) export control regulations.

If required to conduct export control checks, you, upon request by us, shall promptly provide us with all information pertaining to particular end customer, destination and intended use of goods, works and services provided by us, as well as any export control restrictions existing.

The products listed in this catalog list may be subject to European / German and/or US export regulations.

Therefore, any export requiring a license is subject to approval by the competent authorities.

According to current provisions, the following export regulations must be observed with respect to the products featured in this catalog:

AL	<p>Number of the <u>German Export List</u></p> <p>Products marked other than "N" require an export license.</p> <p>In the case of software products, the export designations of the relevant data medium must also be generally adhered to.</p> <p>Goods labeled with an "<u>AL" not equal to "N"</u>" are subject to a European or German export authorization when being exported out of the EU.</p>
ECCN	<p><u>Export Control Classification Number</u></p> <p>Products marked other than "N" are subject to a reexport license to specific countries.</p> <p>In the case of software products, the export designations of the relevant data medium must also be generally adhered to.</p> <p>Goods labeled with an "<u>ECCN" not equal to "N"</u>" are subject to a US re-export authorization.</p>

Even without a label or with an "AL: N" or "ECCN: N", authorization may be required due to the final destination and purpose for which the goods are to be used.

The deciding factors are the AL or ECCN export authorization indicated on order confirmations, delivery notes and invoices.

Errors excepted and subject to change without prior notice.

IA/DT/BT VuL_ohne MZ En 07.07.10

Interactive Catalog on DVD for Industry Automation, Drive Technologies and Low Voltage Distribution	<i>Catalog</i> CA 01		
Drive Systems			
<u>Variable-Speed Drives</u>			
SINAMICS G110, SINAMICS G120 Standard Inverters	D 11.1		
SINAMICS G110D, SINAMICS G120D Distributed Inverters			
SINAMICS G130 Drive Converter Chassis Units	D 11		
SINAMICS G150 Drive Converter Cabinet Units			
SINAMICS GM150, SINAMICS SM150 Medium-Voltage Converters	D 12		
SINAMICS S120 Chassis Format Units and Cabinet Modules	D 21.3		
SINAMICS S150 Converter Cabinet Units			
SINAMICS DCM Converter Units	D 23.1		
<u>Three-phase Induction Motors</u>	D 84.1		
• H-compact			
• H-compact PLUS			
Asynchronous Motors Standardline	D 86.1		
Synchronous Motors with Permanent-Magnet Technology, HT-direct	D 86.2		
DC Motors	DA 12		
SIMOREG DC MASTER 6RA70 Digital Chassis Converters	DA 21.1		
SIMOREG K 6RA22 Analog Chassis Converters	DA 21.2		
<i>PDF: SIMOREG DC MASTER 6RM70 Digital Converter Cabinet Units</i>	DA 22		
SIMOVERT PM Modular Converter Systems	DA 45		
SIEMOSYN Motors	DA 48		
MICROMASTER 420/430/440 Inverters	DA 51.2		
MICROMASTER 411/COMBIMASTER 411	DA 51.3		
SIMOVERT MASTERDRIVES Vector Control	DA 65.10		
SIMOVERT MASTERDRIVES Motion Control	DA 65.11		
Synchronous and asynchronous servomotors for SIMOVERT MASTERDRIVES	DA 65.3		
SIMODRIVE 611 universal and POSMO	DA 65.4		
SIMOTION, SINAMICS S120 and Motors for Production Machines	PM 21		
SINAMICS S110 The Basic Positioning Drive	PM 22		
<u>Low-Voltage Three-Phase-Motors</u>			
IEC Squirrel-Cage Motors	D 81.1		
MOTOX Geared Motors	D 87.1		
<u>Automation Systems for Machine Tools SIMODRIVE</u>	NC 60		
• Motors			
• Converter Systems SIMODRIVE 611/POSMO			
<u>Automation Systems for Machine Tools SINAMICS</u>	NC 61		
• Motors			
• Drive System SINAMICS S120			
<u>Mechanical Driving Machines</u>			
FLENDER Standard Couplings	MD 10.1		
FLENDER SIG Standard industrial gear unit	MD 30.1		
Low-Voltage Power Distribution and Electrical Installation Technology			
Protection, Switching, Measuring & Monitoring Devices	LV 10.1		
Switchboards and Distribution Systems	LV 10.2		
GAMMA Building Management Systems	ET G1		
<i>PDF: DELTA Switches and Socket Outlets</i>	ET D1		
SICUBE System Cubicles and Cubicle Air-Conditioning	LV 50		
SIVACON 8PS Busbar Trunking Systems	LV 70		
Motion Control	<i>Catalog</i>		
SINUMERIK & SIMODRIVE Automation Systems for Machine Tools	NC 60		
SINUMERIK & SINAMICS Equipment for Machine Tools	NC 61		
SINUMERIK 828D BASIC T/BASIC M, SINAMICS S120 Combi and 1FK7/1PH8 motors	NC 82		
SIMOTION, SINAMICS S120 and Motors for Production Machines	PM 21		
SINAMICS S110 The Basic Positioning Drive	PM 22		
Power Supply and System Cabling			
Power supply SITOP	KT 10.1		
System cabling SIMATIC TOP connect	KT 10.2		
Process Instrumentation and Analytics			
Field Instruments for Process Automation	FI 01		
SIREC Recorders and Accessories	MP 20		
SIPART, Controllers and Software	MP 31		
Products for Weighing Technology	WT 10		
Process Analytical Instruments	PA 01		
<i>PDF: Process Analytics, Components for the System Integration</i>	PA 11		
Safety Integrated			
Safety Technology for Factory Automation	SI 10		
SIMATIC HMI/PC-based Automation			
Human Machine Interface Systems/ PC-based Automation	ST 80/ ST PC		
SIMATIC Industrial Automation Systems			
Products for Totally Integrated Automation and Micro Automation	ST 70		
SIMATIC PCS 7 Process Control System	ST PCS 7		
Add-ons for the SIMATIC PCS 7 Process Control System	ST PCS 7.1		
<i>PDF: Migration solutions with the SIMATIC PCS 7 Process Control System</i>	ST PCS 7.2		
SIMATIC NET			
Industrial Communication	IK PI		
SIMATIC Sensors			
Sensor Technology for Factory Automation	FS 10		
Industrial Identification Systems	ID 10		
SINVERT Photovoltaics			
Inverters and Components for Photovoltaic Installations	RE 10		
SIRIUS Industrial Controls			
SIRIUS Industrial Controls	IC 10		
SIRIUS Industrial Controls (selected content from catalog IC 10)	IC 90		
System Solutions			
Applications and Products for Industry are part of the interactive catalog CA 01			

Siemens Industriegetriebe GmbH
Thierbacher Str. 24
09322 PENIG
GERMANY

Subject to change without prior notice
Order No. E86060-K5730-A111-A1-7600
3P.8322.71.01 / Dispo 18407
KG 0711 3.0 ROT 104 En
Printed in Germany
© Siemens AG 2011

www.siemens.com/sig

The information provided in this catalog contains descriptions or characteristics of performance which in case of actual use do not always apply as described or which may change as a result of further development of the products. An obligation to provide the respective characteristics shall only exist if expressly agreed in the terms of contract. Availability and technical specifications are subject to change without notice.

All product designations may be trademarks or product names of Siemens AG or supplier companies whose use by third parties for their own purposes could violate the rights of the owners.

Token fee: 5.00 €

SIEMENS

Catalog MD 30.1 · 2011

FLENDER SIG

emens AG