

FLENDER COUPLINGS

N-EUPEX / N-EUPEX DS

Operating Instructions 3101en
Edition 10/2017

H, HDS



FLENDER COUPLINGS

N-EUPEX / N-EUPEX DS 3101en

Operating Instructions

H, HDS

<u>Introduction</u>	1
<u>Safety instructions</u>	2
<u>Description</u>	3
<u>Application planning</u>	4
<u>Assembly</u>	5
<u>Commissioning</u>	6
<u>Operation</u>	7
<u>Servicing</u>	8
<u>Service and support</u>	9
<u>Disposal</u>	10
<u>Spare parts</u>	11
<u>Technical data</u>	A
<u>Quality documents</u>	B

Legal information

Warning notice system

This manual contains notices you have to observe in order to ensure your personal safety, as well as to prevent damage to property. The notices referring to your personal safety are highlighted in the manual by a safety alert symbol, notices referring only to property damage have no safety alert symbol. These notices shown below are graded according to the degree of danger.

 DANGER
indicates that death or severe personal injury will result if proper precautions are not taken.

 WARNING
indicates that death or severe personal injury may result if proper precautions are not taken.

 CAUTION
indicates that minor personal injury can result if proper precautions are not taken.

NOTICE
indicates that property damage can result if proper precautions are not taken.

If more than one degree of danger is present, the warning notice representing the highest degree of danger will be used. A notice warning of injury to persons with a safety alert symbol may also include a warning relating to property damage.

Qualified Personnel

The product/system described in this documentation may be operated only by **personnel qualified** for the specific task in accordance with the relevant documentation, in particular its warning notices and safety instructions. Qualified personnel are those who, based on their training and experience, are capable of identifying risks and avoiding potential hazards when working with these products/systems.

Proper use of Flender products

Note the following:

 WARNING
Flender products may only be used for the applications described in the catalog and in the relevant technical documentation. If products and components from other manufacturers are used, these must be recommended or approved by Flender. Proper transport, storage, installation, assembly, commissioning, operation and maintenance are required to ensure that the products operate safely and without any problems. The permissible ambient conditions must be complied with. The information in the relevant documentation must be observed.

Trademarks

All names identified by ® are registered trademarks of Flender GmbH. The remaining trademarks in this publication may be trademarks whose use by third parties for their own purposes could violate the rights of the owner.

Disclaimer of Liability

We have reviewed the contents of this publication to ensure consistency with the hardware and software described. Since variance cannot be precluded entirely, we cannot guarantee full consistency. However, the information in this publication is reviewed regularly and any necessary corrections are included in subsequent editions.

Table of contents

1	Introduction.....	9
1.1	About these instructions.....	9
1.2	Text attributes.....	9
1.3	Copyright.....	9
2	Safety instructions.....	11
2.1	General information.....	11
2.2	Intended use.....	13
2.3	Safety instructions for a coupling for use in potentially explosive atmospheres.....	13
2.3.1	Marking.....	13
2.3.2	Conditions of use.....	15
2.4	General warning notices.....	16
3	Description.....	19
4	Application planning.....	21
4.1	Transport of the coupling.....	21
4.2	Storage of the coupling.....	21
5	Assembly.....	23
5.1	Preparatory work.....	23
5.1.1	Milling the parallel keyway.....	24
5.1.2	Milling the parallel keyway.....	25
5.1.3	Machining an axial locking mechanism.....	25
5.1.4	Balancing the coupling.....	28
5.2	Assembling the coupling.....	30
5.3	Aligning the coupling.....	31
5.3.1	Purpose of alignment.....	31
5.3.2	Possible misalignment.....	32
5.3.2.1	Axial misalignment.....	32
5.3.2.2	Angular misalignment.....	32
5.3.2.3	Radial misalignment.....	33
6	Commissioning.....	35
7	Operation.....	37
7.1	Normal operation of the coupling.....	37
7.2	Faults - causes and rectification.....	37
7.2.1	Procedure in the event of malfunctions.....	37
7.2.2	Identifying the fault cause.....	37
7.2.2.1	Possible faults.....	38
7.2.2.2	Possible causes.....	39

7.2.3	Correcting faults.....	40
7.2.3.1	Replacing wearing parts.....	40
7.2.3.2	Correcting the changed alignment.....	41
8	Servicing.....	43
8.1	Maintenance intervals.....	43
8.2	Maximum permissible torsional backlash.....	44
8.3	Replacing wearing parts.....	45
8.4	Removing the coupling.....	46
9	Service and support.....	47
9.1	Contact.....	47
10	Disposal.....	49
11	Spare parts.....	51
11.1	Ordering spare parts.....	51
11.2	Spare parts drawing and spare parts list.....	52
A	Technical data.....	53
A.1	Speeds, geometry data and weights.....	53
A.1.1	Type H.....	53
A.1.2	Type HDS.....	55
A.2	Shaft misalignment values during operation.....	57
A.3	Tightening torques and widths A/F.....	58
A.4	Tightening procedure.....	58
A.5	Flexible elements (12).....	59
A.5.1	Use and storage of flexible elements (12).....	59
A.5.2	N-EUPEX flexible elements (12).....	59
A.5.3	N-EUPEX DS flexible elements (12).....	60
B	Quality documents.....	61
B.1	Declaration of Conformity.....	61

Tables

Table 2-1	General warnings.....	11
Table 2-2	Temperature classes (TX) for explosive atmospheres as a result of gases, vapours or mists.....	16
Table 2-3	Maximum surface temperature (TX) for an explosive atmosphere as a result of dust/air mixtures.....	16
Table 4-1	Types of preservative agents for long-term storage.....	22
Table 5-1	Recommended assigned fits for bores with parallel key connection.....	24
Table 5-2	Position of the parallel keyway.....	25
Table 5-3	Diameter and axial position of the tapped hole, tightening torque.....	26
Table 5-4	Position of the tapped hole with respect to the parallel keyway.....	27

Table 7-1	Table of faults.....	38
Table 8-1	Maintenance intervals.....	43
Table 8-2	Maximum permissible torsional backlash for the type H (sizes 80 to 200).....	44
Table 8-3	Maximum permissible torsional backlash for the type H (sizes 225 to 440).....	44
Table 8-4	Maximum permissible torsional backlash for the type HDS (sizes 88 to 218).....	44
Table 8-5	Maximum permissible torsional backlash for the type HDS (sizes 245 to 472).....	45
Table 11-1	Spare parts list for types H and HDS.....	52
Table A-1	Speeds, geometry data and weights of type H.....	53
Table A-2	Speeds, geometry data and weights of type HDS.....	55
Table A-3	Maximum permissible shaft misalignment values during operation.....	57
Table A-4	Tightening torques for part 22 of types H and HDS.....	58
Table A-5	Tightening procedure.....	58
Table A-6	N-EUPEX flexible elements.....	59
Table A-7	N-EUPEX DS flexible elements.....	60

Figures

Figure 3-1	Types H and HDS.....	19
Figure 4-1	Transport symbols.....	21
Figure 5-1	Tolerances for finished bore.....	25
Figure 5-2	Diameter and axial position of the tapped hole in the hub.....	26
Figure 5-3	Position of the balancing bore for single-plane balancing.....	29
Figure 5-4	Position of the balancing bore for two-plane balancing.....	29
Figure 5-5	Possible misalignment.....	32
Figure 8-1	Markings for calculating the torsional backlash.....	44
Figure 11-1	Spare parts drawing for types H and HDS.....	52
Figure A-1	Type H.....	53
Figure A-2	Type HDS.....	55

Introduction

1.1 About these instructions

These instructions describe the coupling and provide information about its handling - from assembly to maintenance. Please keep these instructions for later use.

Please read these instructions prior to handling the coupling and follow the information in them.

1.2 Text attributes

The warning notice system is explained on the back of the inner cover. Always follow the safety information and notices in these instructions.

In addition to the warning notices, which have to be observed without fail, you will find the following text attributes in these instructions:

1. Procedural instructions are shown as a numbered list. Always perform the steps in the order given.

- Lists are formatted as bulleted lists.
 - The dash is used for lists at the second level.

(1) Numbers in brackets are part numbers.

Note

A note is an important item of information about the product, the handling of the product or the relevant section of the instructions. The note provides you with help or further suggestions/ ideas.

1.3 Copyright

The copyright for these instructions is held by Flender.

These instructions must not be used wholly or in parts without our authorisation or be given to third parties.

If you have any technical queries, please contact our factory or one of our service outlets (refer to Service and support (Page 47)).

Safety instructions

2.1 General information

Instructions

These instructions are part of the delivery. Always keep these instructions close to the coupling.

Please make sure that every person who is commissioned to work on the coupling has read and understood these instructions prior to handling the coupling and observes all of the points.

Only the knowledge of these instructions can avoid faults on the coupling and ensure fault-free and safe operation. Non-adherence to the instructions can cause product or property damage or personal injury. Flender does not accept any liability for damage or operating failures that are due to non-adherence to these instructions.







State of the art

The coupling described here has been designed in consideration of the latest findings for demanding technical requirements. This coupling is state-of-the-art at the time of printing these instructions.





In the interest of further development, Flender reserves the right to make such changes to the individual components and accessories that increase performance and safety whilst maintaining the essential features.

Symbols

Table 2-1 General warnings

ISO	ANSI	Warning
		Warning - hazardous electrical voltage
		Warning - explosive substances
	---	Warning - entanglement hazard
	---	Warning - hot surfaces
	---	Warning - substances that are harmful to health or are irritants

2.1 General information

ISO	ANSI	Warning
	---	Warning - corrosive substances
	---	Warning - suspended load
	---	Warning - hand injuries
		ATEX certification

Explanation regarding Machinery Directive 2006/42/EC

The couplings described here are “components” in accordance with the Machinery Directive and do not require a declaration of incorporation.

ATEX Directive

The term "ATEX Directive" used in these instructions stands for the harmonisation legislation of the European Union in compliance with the declaration of conformance for equipment and protective systems for correct use in hazardous zones.

Protective clothing

In addition to the generally prescribed personal protective equipment (safety shoes, overalls, helmet, etc.), also wear suitable safety gloves and safety goggles when handling the coupling.

Using the coupling

The relevant work safety and environmental protection regulations must be complied with at all times during transport, assembly, installation, dismantling, operation and maintenance of the coupling.

Only qualified personnel may operate, assemble, maintain and repair the coupling. Information about qualified personnel can be found in the legal notes at the beginning of these instructions.

If lifting gear or load suspension devices are used for transporting, these have to be suitable for the weight of the coupling.

If the coupling has visible damage, it may not be assembled or put into operation.

The coupling may only be operated in a suitable housing or with touch protection according to applicable standards. This also applies to test runs and rotational direction checks.

Work on the coupling

Only carry out work on the coupling when it is not in operation and is not under load.

Secure the drive unit against being switched on accidentally. Attach a notice to the switch stating clearly that work is being carried out on the coupling. Ensure that the entire unit is not under load.

2.2 Intended use

Only use the coupling according to the conditions specified in the service and delivery contract and the technical data in the annex. Deviating operating conditions are considered improper use. The user or owner of the machine or plant is solely liable for any resulting damage.

When using the coupling please specifically observe the following:

- Do not make any modifications to the coupling that go beyond the permissible machining described in these instructions. This also applies to touch protection facilities.
- Only use original spare parts from Flender. Flender only accepts liability for original spare parts from Flender.
Other spare parts are not tested and approved by Flender. Non-approved spare parts may possibly change the design characteristics of the coupling and thus impact active and/or passive safety.
Flender will accept no liability or warranty whatsoever for damage occurring as a result of the use of non-approved spare parts. The same applies to any accessories that were not supplied by Flender.

If you have any queries, please contact our customer service (see Service and support (Page 47)).

2.3 Safety instructions for a coupling for use in potentially explosive atmospheres

2.3.1 Marking

You can find a description of the coupling parts in chapter Description (Page 19).

A coupling designed in accordance with the ATEX Directive has a marking on the coupling parts.

Coupling part 1 without electrically insulating flexible elements

One of the following markings is visible on the outer diameter of coupling part 1:

Version 1:

Flender GmbH

46393 Bocholt - Germany

FLENDER couplings N-EUPEX <Year of manufacture>







II 2GD c IIC TX



I M2 c X

2.3 Safety instructions for a coupling for use in potentially explosive atmospheres



Version 2:

Flender GmbH		 II 2G c IIC T4/T5/T6 -30 °C ≤ Ta ≤ +80 °C/+70 °C/+55 °C
46393 Bocholt - Germany		 II 2D c T 110 °C -30 °C ≤ Ta ≤ +80 °C
FLENDER couplings N-EUPEX	<Year of manufacture>	 I M2 c -30 °C ≤ Ta ≤ +80 °C



Coupling part 1 with flexible elements for low-temperature use

One of the following markings is visible on the outer diameter of coupling part 1:

Version 1:

Flender GmbH		 II 2GD c IIC TX
46393 Bocholt - Germany		 I M2 c X
FLENDER couplings N-EUPEX	<Year of manufacture>	



Version 2:

Flender GmbH		 II 2G c IIC T6 -50 °C ≤ Ta ≤ +50 °C
46393 Bocholt - Germany		 II 2D c T 80 °C -50 °C ≤ Ta ≤ +50 °C
FLENDER couplings N-EUPEX	<Year of manufacture>	 I M2 c -50 °C ≤ Ta ≤ +50 °C





Coupling part 1 with electrically insulating flexible elements

One of the following markings is visible on the outer diameter of coupling part 1:

Version 1:

Flender GmbH		 II 2GD c IIB TX
46393 Bocholt - Germany		 I M2 c X
FLENDER couplings N-EUPEX	<Year of manufacture>	

Version 2:

Flender GmbH		 II 2G c IIB T4/T5/T6 -30 °C ≤ Ta ≤ +80 °C/+70 °C/+55 °C
46393 Bocholt - Germany		 II 2D c T 110 °C -30 °C ≤ Ta ≤ +80 °C
FLENDER couplings N-EUPEX	<Year of manufacture>	 I M2 c -30 °C ≤ Ta ≤ +80 °C

Coupling part 5

Coupling part 5 is stamped with .

Undrilled or predrilled coupling

A coupling part with Ex marking, the letter "U" and the Flender order number has been delivered undrilled or predrilled.

Note

Undrilled or predrilled coupling with Ex marking

Flender only supplies an undrilled or predrilled coupling with Ex marking on the condition that the customer assumes the responsibility and liability for correct finishing work in a declaration of exemption.

2.3.2 Conditions of use

Note

Note also the material-dependent permissible ambient temperature of the flexible elements (12) in accordance with sections N-EUPEX flexible elements (12) (Page 59) and N-EUPEX DS flexible elements (12) (Page 60).

A coupling designed in accordance with the ATEX Directive is suitable for the following conditions of use:

- Equipment group I
 - Category M2
- Equipment group II
 - Category 2 and 3
 - Group of substances G, zone 1 and 2
 - Group of substances D, zone 21 and 22
 - Explosion group IIA, IIB and IIC
 - Explosion group IIA and IIB when electrically insulating flexible elements are used

Conditions of use for products with TX marking

The maximum ambient temperature stated in the following tables applies to the temperature in the direct vicinity of the coupling and the temperature of adjacent components.

2.4 General warning notices

1. Gases, vapours or mists

Check the ambient temperature for use of the coupling in the relevant temperature class.

Table 2-2 Temperature classes (TX) for explosive atmospheres as a result of gases, vapours or mists

Max. ambient temperature	Temperature class
80 °C	T4
70 °C	T5
55 °C	T6

2. Dust/air mixtures

Check the ambient temperature.

Table 2-3 Maximum surface temperature (TX) for an explosive atmosphere as a result of dust/air mixtures

Max. ambient temperature	Max. surface temperature
80 °C	110 °C

Notes concerning operation of the coupling in potentially explosive atmospheres

- Only use the coupling underground in mines in potentially explosive atmospheres together with drive motors that can be switched off in the event of the formation of an explosive atmosphere.
- Earth machines that are connected via the coupling with a leakage resistance of less than 10⁶ Ω.
- If you want to use a coated coupling in potentially explosive atmospheres, please note the requirements concerning the conductivity of the paint and the limitation on the paint layer thickness applied in accordance with EN 13463-1. No build-up of electrostatic charges is to be expected with a paint layer thickness of less than 200 µm.

2.4 General warning notices



<p>⚠ DANGER</p> <p>Danger due to bursting of the coupling</p> <p>The coupling may burst if it is not used properly. There is a risk of fatal injury from flying fragments. Bursting of the coupling can lead to an explosion in potentially explosive atmospheres.</p> <ul style="list-style-type: none"> • Use the coupling for the purpose for which it is intended.



! DANGER

Risk of explosion when using coupling parts without Ex marking

Coupling parts without Ex marking have not been approved for use in potentially explosive atmospheres. These coupling parts can lead to an explosion during operation.

- Only use couplings with Ex marking in potentially explosive atmospheres.



! DANGER

Danger

Risk of injury due to the use of unsuitable and/or damaged components. The use of unsuitable and/or damaged components can lead to an explosion in potentially explosive atmospheres.

- Observe the information regarding conditions of use.



! DANGER

Danger of explosion

Improper operation of the coupling can lead to an explosion in potentially explosive atmospheres.

- Please observe the notes concerning operation of the coupling in potentially explosive atmospheres.



! DANGER

Danger from hot coupling parts

Risk of injury due to hot surfaces. Hot coupling parts can lead to an explosion in potentially explosive atmospheres.

- Wear suitable protective equipment (gloves, safety goggles).
- Ensure that the area is not at risk of explosion.



! WARNING

Risk of chemical burns due to chemical substances

There is a risk of chemical burns when handling aggressive cleaning agents.

- Please observe the manufacturer's information on how to handle cleaning agents and solvents.
- Wear suitable protective equipment (gloves, safety goggles).

! CAUTION

Physical injury

Risk of injury due to falling coupling parts.

- Secure the coupling parts to prevent them from falling.

Description

The N-EUPEX or N-EUPEX DS couplings described here are torsionally flexible, damping pin couplings and are available in various types and sizes. The couplings can be used in accordance with the ATEX Directive in potentially explosive atmospheres if they have a CE marking.

Type H is fail-safe. Type HDS has no fail-safe device.

Types H and HDS are designs that feature an intermediate sleeve (coupling part 6).

These instructions describe the assembly and operation of an N-EUPEX or N-EUPEX DS coupling arranged horizontally with a shaft-hub connection made by a cylindrical or conical bore with parallel key. Please consult Flender if you want to use a different type of installation.

Application

N-EUPEX couplings are designed for use in all kinds of machines.

N-EUPEX DS couplings are used for applications which require the input and output to be disconnected from one another in the event of destruction of the flexible elements.

Design

The illustration shows the various types with their constituent parts and their part numbers.

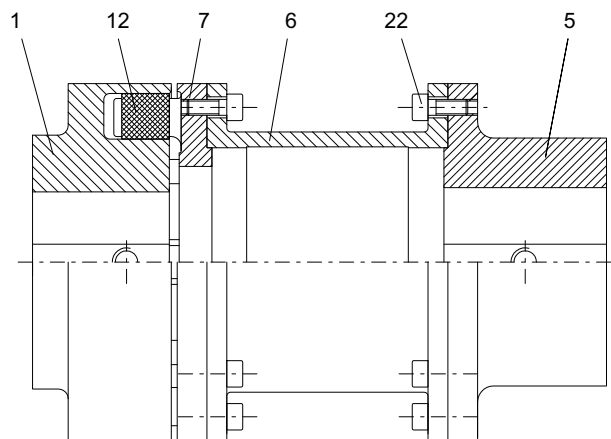

- 1 Coupling part 1
- 5 Coupling part 5
- 6 Coupling part 6
- 7 Coupling part 7
- 12 Flexible element
- 22 Cylinder-head screw

Figure 3-1 Types H and HDS

Application planning

Check the delivery for damage and for completeness. Report any damage and/or missing parts to Flender immediately.

The coupling is delivered in individual parts and preassembled groups. Preassembled groups may not be dismantled.

4.1 Transport of the coupling



 WARNING
<p>Severe personal injury due to improper transport</p> <p>Severe personal injury due to falling components or due to crushing. Damage to coupling parts possible due to use of unsuitable transport means.</p> <ul style="list-style-type: none"> • Only use lifting gear and load suspension devices with sufficient load bearing capacity for transport. • Please observe the symbols applied on the packaging.

If not specifically contractually agreed otherwise, the packaging complies with the HPE Packaging Directive.

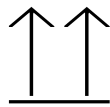

This way up



Fragile



Keep dry

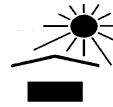

Keep dry

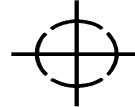

Centre of gravity



Do not use hand hook



Attach here

Figure 4-1 Transport symbols

4.2 Storage of the coupling

NOTICE
<p>Property damage due to improper storage</p> <p>Negative changes to the physical properties of the coupling and/or coupling damage.</p> <ul style="list-style-type: none"> • Please observe the information about storing the coupling.

4.2 Storage of the coupling

The coupling, unless not specifically ordered otherwise, is supplied with preservation and can be stored for up to 3 months.

Note

Information about storing the coupling

- Ensure that the storage room is dry (relative humidity < 65 %) and free of dust.
- Ensure that there is no condensation.
- Do not store the coupling together with corrosive chemicals, acids, caustic solutions, etc.
- If the coupling contains elastomer components, ensure that there are no devices in the storage room that produce ozone, such as fluorescent lights, mercury vapour lamps or high-voltage electrical equipment.
- Store the coupling on suitable supports or in suitable containers.

Long-term storage

NOTICE
Property damage due to improper long-term storage
Negative changes to the physical properties of the coupling and/or coupling damage.
<ul style="list-style-type: none"> • Note the handling instructions for long-term storage.

1. You can find the required type of preservative agent in the following table (types of preservative agents for long-term storage).
2. Remove the elastomer components. These must not come into contact with cleaning agents and long-term preservative agents.
3. Clean the coupling parts.
4. Apply the stipulated preservative agent.
5. Store the coupling parts and the elastomer components separately.

Table 4-1 Types of preservative agents for long-term storage

Preservative agents	Features	Indoor storage	Outdoor storage
Oil spray	Anti-corrosion agent	Up to 12 months	Up to 4 months
Tectyl 846 or similar	Long-term preservative agent on wax basis	Up to 36 months	Up to 12 months
Emulsion cleaner + VCI foil	Active system, reusable	Up to 5 years	Up to 5 years

Assembly

Assembly of the coupling comprises the following steps:

- Preparatory work (Page 23)
- Assembling the coupling (Page 30)
- Aligning the coupling (Page 31)



DANGER

Danger due to bursting of the coupling

If you do not observe the information stipulated here regarding assembly, this can lead to bursting of the coupling during operation. There is a risk of fatal injury from flying fragments. Bursting of the coupling can lead to an explosion in potentially explosive atmospheres.

- Please observe all the stipulations concerning assembly.

Note

Information about the assembly of the coupling

- Only use undamaged components for the assembly of the coupling.
- Follow the assembly sequence.
- Please ensure that there is sufficient space at the assembly location and that the location is tidy and clean in order to be able to assemble and maintain the coupling without any risk.
- If a dimension drawing has been created for the coupling, please observe the information it contains as a matter of priority.

5.1 Preparatory work

Note

Please consult Flender if you want to machine a conical finished bore.

Carry out the following steps if the coupling does not have a finished bore:

- Milling the parallel keyway (Page 24)
- Milling the parallel keyway (Page 25)
- Machining an axial locking mechanism (Page 25)
- Balancing the coupling (Page 28)

Note

The customer is responsible for execution of the finishing work on the coupling. Flender shall have no liability whatsoever for claims under warranty arising from finishing work that has not been carried out adequately.

5.1.1 Milling the parallel keyway

The diameter of the finished bore depends on the shaft used.

Recommended assigned fits

In the following table you can find the recommended assigned fits for bores with a parallel key connection. The assigned fit m6 / H7 is especially suitable for a host of applications.

Table 5-1 Recommended assigned fits for bores with parallel key connection

Description	Push fit		Press fit		Interference fit		
	Not suitable for reversing operation		Suitable for reversing operation				
Shaft tolerance	j6	h6	h6	k6	m6	n6	h6
Bore tolerance	H7	J7	K7	H7	H7	H7	M7

Procedure

1. Remove the flexible elements (12).
2. Remove the preservation and clean the coupling parts 1 (1) and 5 (5) to be machined.
3. Clamp the coupling to the areas marked with  in the diagram below.
4. Machine the finished bore in accordance with the diagram below.

Note

Diameter of the finished bore

The diameter of the finished bore may not exceed the specified maximum diameter.

- Please observe the maximum diameters specified in section Speeds, geometry data and weights (Page 53).

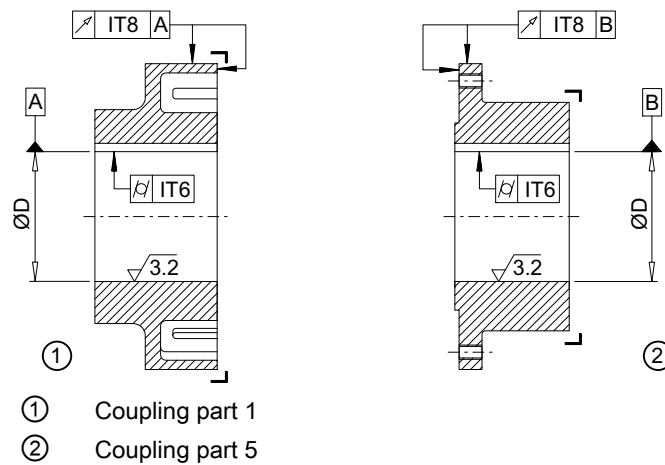

Figure 5-1 Tolerances for finished bore

5.1.2 Milling the parallel keyway

Position of the parallel keyway

The table below states the required position for the parallel keyway in the coupling parts depending on the coupling type.

Table 5-2 Position of the parallel keyway

Coupling part	Coupling	Position of the parallel keyway
1	N-EUPEX	Centred between the flexible element webs
1	N-EUPEX DS	Centred between the flexible element pockets
5	N-EUPEX N-EUPEX DS	Beneath a tapped hole

Applicable standards

- If the coupling is intended for use under normal operating conditions, mill the parallel keyway according to DIN 6885/1 ISO JS9.
- If the coupling is intended for reversing operation, mill the parallel keyway according to DIN 6885/1 ISO P9.
- If you want to mill a parallel keyway that does not correspond to DIN 6885/1, please consult Flender.

5.1.3 Machining an axial locking mechanism

The coupling part is secured by a set screw or an end plate to prevent axial movements.

Please consult Flender if you want to use an end plate.

Note the following when using a set screw:

- Diameter and axial position of the tapped hole in the hub
- Position of the tapped hole with respect to the parallel keyway
- Selection of the set screw

Diameter and axial position of the tapped hole in the hub

The following diagram shows the axial position of the tapped hole.

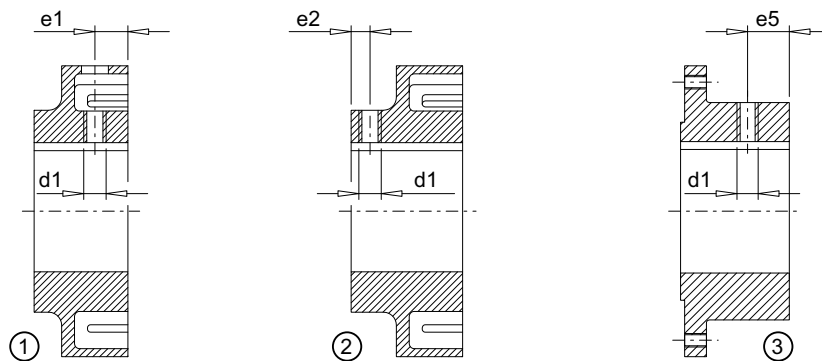

- ① Coupling part 1; axial position of the tapped hole up to size 125 / 135
- ② Coupling part 1; axial position of the tapped hole as of size 140 / 152
- ③ Coupling part 5

Figure 5-2 Diameter and axial position of the tapped hole in the hub

The following table contains the values for the diameter and axial position of the tapped hole depending on the size of the coupling.

Table 5-3 Diameter and axial position of the tapped hole, tightening torque

Size	d1	e1 mm	e2 mm	e5 mm	Tightening torque
					T _A Nm
80 / 88	M6	11	-	15	4
95 / 103	M6	15	-	20	4
110 / 118	M6	18	-	25	4
125 / 135	M8	20	-	25	8
140 / 152	M8	-	13	30	8
160 / 172	M10	-	13	35	15
180 / 194	M12	-	16	40	25
200 / 218	M12	-	20	45	25

Size	d1	e1 mm	e2 mm	e5 mm	Tightening torque
					T _A Nm
225 / 245	M12	-	22	50	25
250 / 272	M16	-	24	55	70
280	M16	-	28	60	70
315	M16	-	35	65	70
350	M20	-	40	70	130
400	M20	-	50	80	130
440	M24	-	60	90	230

Apply the recommended tightening torques in accordance with the stipulations in section Tightening procedure (Page 58).

Position of the tapped hole with respect to the parallel keyway

The tapped hole for the set screw is generally positioned on the parallel keyway. This does not apply to the coupling parts listed in the following table.

Table 5-4 Position of the tapped hole with respect to the parallel keyway

Coupling part	Size	Finished bore [mm]	Position of the tapped hole
1	80 / 88	≥ 25	Offset 180° relative to parallel keyway
	95 / 103	≥ 38	Offset 180° relative to parallel keyway

Selection of the set screw

 CAUTION
Physical injury Danger of injury from protruding set screw. <ul style="list-style-type: none"> • Please observe the information about selecting the set screw.

As set screws use threaded studs in accordance with ISO 4029 with a toothed cup point. The size of the set screw is determined by the bore made. The set screw should fill out the tapped hole as much as possible and must not protrude beyond the hub.

5.1.4 Balancing the coupling

Notes on balancing the coupling

NOTICE
Damage to coupling part 1 (1) If you completely drill through the base on coupling part 1 (1), then coupling part 1 (1) is no longer allowed to be used for operation. <ul style="list-style-type: none">• Please observe the stipulations about machining the balancing hole.

Please note the following when balancing the coupling:

- Select the balancing quality according to the application (but at least G16 in accordance with DIN ISO 21940).
- Observe the balancing specification according to DIN ISO 21940-32.
- Machine the balancing bore on a large radius with adequate clearance to the flexible element webs / pockets and to the cams and the outer circumference.

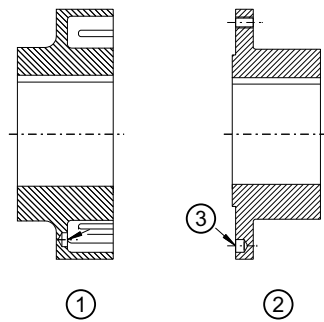

- ① Part 1 for N-EUPEX or N-EUPEX DS coupling
 ② Part 5 for N-EUPEX or N-EUPEX DS coupling
 ③ Balancing bore

Figure 5-3 Position of the balancing bore for single-plane balancing

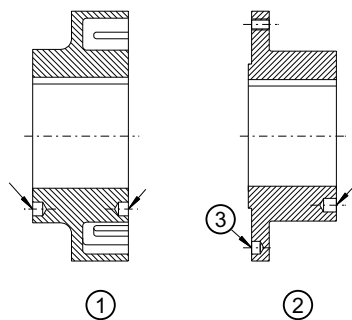

- ① Part 1 for N-EUPEX or N-EUPEX DS coupling
 ② Part 5 for N-EUPEX or N-EUPEX DS coupling
 ③ Balancing bore

Figure 5-4 Position of the balancing bore for two-plane balancing

Note

A better balancing result can be achieved by balancing the coupling parts (5, 6 and 7) when they are bolted together as an assembly. When balancing all parts together, mark the position of the components relative to one another.

5.2 Assembling the coupling

NOTICE
Property damage Damage to the elastomer components from cleaning agents. <ul style="list-style-type: none">• Ensure that the elastomer components do not come into contact with cleaning agents.

NOTICE
Property damage Damage to the shaft end, the coupling parts and/or the parallel key. <ul style="list-style-type: none">• Note the following handling instruction.

Procedure

1. Unscrew the set screw until it is no longer possible for there to be a collision with the parallel key or the shaft.
2. Clean the bores and shaft ends.
3. Coat the bores of coupling parts 1 (1) and 5 (5) and the shafts with MoS₂ assembly paste (e.g. Microgleit LP 405).
4. Mount the coupling parts 1 (1) and 5 (5) on the shaft.

Note

Coupling parts with conical bore

Mount the coupling parts 1 (1) and 5 (5) with conical bore and parallel keyway on the shaft in cold condition. Secure the coupling parts with suitable end plates without pulling the coupling parts further onto the cone (fitting dimension = 0).

Note

Coupling parts with cylindrical bore

To make assembly easier, you can heat coupling parts 1 (1) and 5 (5) with cylindrical bore up to a maximum of 150 °C if required. Note when doing this the temperature range of the flexible elements (12) (see sections N-EUPEX flexible elements (12) (Page 59) and N-EUPEX DS flexible elements (12) (Page 60)). Remove the flexible elements (12) if necessary. Protect adjacent components against damage and heating to temperatures above 80 °C.

5. Secure the coupling parts 1 (1) and 5 (5) with a set screw or an end plate. When securing with a set screw the shaft must not protrude or be set back from the inner side of the hub.
6. Tighten up the set screw or the screw to attach the end plate to the specified tightening torque T_A (for the set screw please see section Machining an axial locking mechanism (Page 25)).

7. If you have removed the flexible elements (12), reinstall them.
8. Bolt the coupling part 5 (5) to the "zero face" of the coupling part 6 (6) and tighten the bolts to the specified torque T_A (see section Tightening torques and widths A/F (Page 58)).
The "zero face" of the coupling part 6 (6) is marked by a 0.2 mm deep groove around the circumference of the flange. If the individual radial and axial runout deviations of the coupling parts 5 (5), 6 (6) and 7 (7) add up unfavourably, the radial runout deviation can increase further. You can reduce this by changing the bolting position of the coupling parts 5 (5) and 6 (6).

5.3 Aligning the coupling

5.3.1 Purpose of alignment

The shafts that are joined by the coupling are never on an ideal precise axis but have a certain amount of misalignment.

Misalignment in the coupling leads to restoring forces that can stress adjacent machine parts (e.g. the bearings) to an unacceptable extent.

The misalignment values in operation result from the following:

- Misalignment due to assembly
Incorrect position due to a lack of precision when aligning
- Misalignment due to operation
Example: Load-related deformation, thermal expansion

You can minimise misalignment by aligning after assembly. A lower misalignment in the coupling has the following advantages:

- Reduced wear of the elastomer components
- Reduced restoring forces
- Misalignment reserves for operation of the coupling

You can find the maximum permitted shaft misalignment values during operation in section Shaft misalignment values during operation (Page 57).

5.3.2 Possible misalignment

The following types of misalignment can occur:

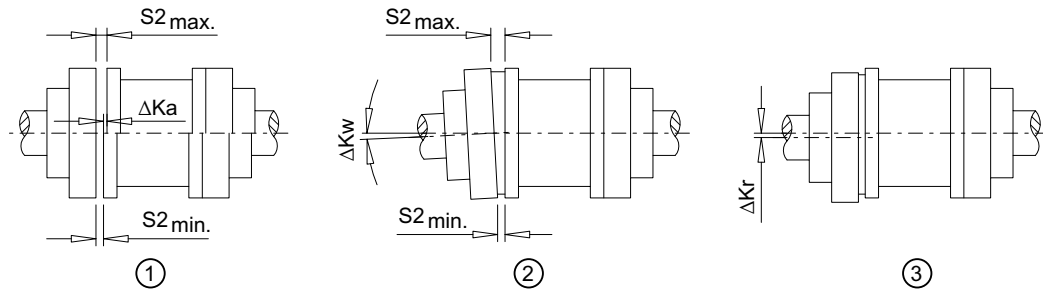

- ① Axial misalignment (ΔK_a)
- ② Angular misalignment (ΔK_w)
- ③ Radial misalignment (ΔK_r)

Figure 5-5 Possible misalignment

5.3.2.1 Axial misalignment

Set the axial misalignment ΔK_a to a value within the permissible tolerance range of dimension S2.

You can find the values for dimension S2 in section Speeds, geometry data and weights (Page 53).

5.3.2.2 Angular misalignment

Determine the value $\Delta S2$ ($\Delta S2 = S2_{max} - S2_{min}$). The determined value $\Delta S2$ may not exceed the value $\Delta S2_{perm}$.

You can find the values for $\Delta S2_{perm}$ in section Shaft misalignment values during operation (Page 57).

If required, you can calculate the angular misalignment ΔK_w as follows:

$$\Delta K_w [\text{rad}] = \Delta S2 / DA$$

$$\Delta K_w [\text{deg}] = (\Delta S2 / DA) \cdot (180 / \pi)$$

If required, you can calculate the permissible angular misalignment $\Delta K_{w_{perm}}$ as follows:

$$\Delta K_{w_{perm}} [\text{rad}] = \Delta S2_{perm} / DA$$

$$\Delta K_{w_{perm}} [\text{deg}] = (\Delta S2_{perm} / DA) \cdot (180 / \pi)$$

DA in mm see section Speeds, geometry data and weights (Page 53)

$\Delta S2_{perm}$ see section Shaft misalignment values during operation (Page 57)

5.3.2.3 Radial misalignment

Determine the value ΔK_r . The determined value ΔK_r may not exceed the value $\Delta K_{r_{perm}}$.

You can find the permissible radial misalignment $\Delta K_{r_{perm}}$ in section Shaft misalignment values during operation (Page 57).



! DANGER

Danger due to igniting deposits

During use in potentially explosive atmospheres deposits from heavy metal oxides (rust) can ignite due to friction, impact or friction sparks and lead to an explosion.

- Ensure through the use of an enclosure or other suitable measures that the deposition of heavy metal oxides (rust) on the coupling is not possible.

In order to ensure safe commissioning, carry out various tests prior to commissioning.

Testing before commissioning



! DANGER

Danger

Overload conditions can occur during the commissioning of the coupling. The coupling can burst and metal parts can be flung out. There is a risk of fatal injury from flying fragments. Bursting of the coupling can lead to an explosion in potentially explosive atmospheres.

- Carry out the tests prior to commissioning.
- Do not touch the rotating coupling.

1. Check the tightening torques of the screws of the coupling in accordance with section Tightening torques and widths A/F (Page 58).
2. Check the tightening torques of the foundation bolts of the coupled machines.
3. Check whether the enclosures (coupling guard, touch protection) have been installed and that the function of the coupling has not been adversely affected by the enclosure. This also applies to test runs and rotational direction checks.

Operation

7.1 Normal operation of the coupling

The coupling runs quietly and shock-free during normal operation.

7.2 Faults - causes and rectification

A form of behaviour which is different to normal operation is classed as a fault and has to be rectified immediately.

Look out specifically for the following faults during coupling operation:

- Unusual coupling noise
- Sudden occurrence of shocks

7.2.1 Procedure in the event of malfunctions



DANGER

Danger due to bursting of the coupling

There is a risk of fatal injury from flying fragments. Bursting of the coupling can lead to an explosion in potentially explosive atmospheres.

- Switch off the unit at once if any malfunctions occur.
- Note during the maintenance work the possible causes of faults and the notes on rectifying them.

Proceed as described below if there is a malfunction of the coupling during operation:

1. De-energise the drive immediately.
2. Initiate the required action for repair, taking into consideration the applicable safety regulations.

If you cannot determine the cause or if you cannot carry out repair work with your own means, request one of our customer service technicians.

7.2.2 Identifying the fault cause

Faults occur frequently due to application errors or they occur due to operational circumstances such as wear of wearing parts or changes to the system.

The faults and fault causes listed below only serve as an indication for troubleshooting. In the case of a complex system be sure to include all the system components in the search for the fault.



<p>! WARNING</p> <p>Physical injury</p> <p>Injury from rotating parts.</p> <ul style="list-style-type: none"> • Only carry out work on the coupling when it is not moving. • Secure the drive unit against being operated accidentally. • Attach a notice to the switch stating clearly that work is being carried out on the coupling. • Before starting any work, make sure that the unit is free from loads.

Intended use

The coupling is only approved for the applications specified in these instructions. Please observe all the stipulations in section Intended use (Page 13).

7.2.2.1 Possible faults

Table 7-1 Table of faults

Fault	Cause	Rectification
Sudden changes in the noise level and/or sudden occurrences of shocks	Wear of wearing parts	Follow the instructions given in section Replacing wearing parts (Page 40).
	Changed alignment	Follow the instructions given in section Correcting the changed alignment (Page 41).
	Coupling not suitable for the operating conditions. Check the possible causes given in section Unsuitable coupling (Page 39).	Use a coupling that is suitable for the operating conditions.
	Incorrect assembly of the coupling. Check the possible causes given in sections Assembly-related causes (Page 39) and Specific installation-related and maintenance-related causes (Page 40).	Reassemble the coupling in accordance with these instructions. Please observe all the stipulations and requirements given in chapter Assembly (Page 23).
	Incorrect maintenance of the coupling. Check the possible causes given in sections Maintenance-related causes (Page 40) and Specific installation-related and maintenance-related causes (Page 40).	Please observe all the stipulations and requirements given in chapter Servicing (Page 43).

Fault	Cause	Rectification
Presence of vibration	Coupling not suitable for the operating conditions. Check the possible causes given in section Unsuitable coupling (Page 39).	Use a coupling that is suitable for the operating conditions.
	Incorrect assembly of the coupling. Check the possible causes given in sections Assembly-related causes (Page 39) and Specific installation-related and maintenance-related causes (Page 40).	Reassemble the coupling in accordance with these instructions. Please observe all the stipulations and requirements given in chapter Assembly (Page 23).
	Incorrect maintenance of the coupling. Check the possible causes given in sections Maintenance-related causes (Page 40) and Specific installation-related and maintenance-related causes (Page 40).	Please observe all the stipulations and requirements given in chapter Servicing (Page 43).

7.2.2.2 Possible causes

Unsuitable coupling

- Important information on the description of the drive unit and the environment were not available when the coupling was chosen.
- System torque too high and/or torque dynamics not permissible.
- System speed too high.
- Application factor not selected correctly.
- Chemically aggressive environment not taken into consideration.
- Coupling not suitable for the ambient temperature.
- Diameter and/or assigned fit of the finished bore not permissible.
- Width across corners of the parallel keyways greater than the width across corners of the parallel keyways in accordance with DIN 6885/1 for the maximum permissible bore.
- Shaft-hub connection incorrectly sized.
- Maximum permissible load conditions not taken into consideration.
- Maximum permissible overload conditions not taken into consideration.
- Dynamic load conditions not taken into consideration.
- Coupling and the machine and/or drive train form a critical torsional, axial or bending vibration system.

Assembly-related causes

- Damaged parts installed.
- Shaft diameter outside the stipulated tolerance range.

- Coupling parts interchanged and hence not assigned to the specified shaft.
- Stipulated locking elements to prevent axial movements not installed.
- Stipulated tightening torques not adhered to.
- Bolts inserted dry or greased.
- Flange surfaces of screwed connections not cleaned.
- Alignment and/or shaft misalignment values not set in accordance with the instructions.
- Coupled machines were not correctly connected to the foundation so that a shifting of the machines leads to an impermissible displacement of the coupling parts.
- Coupled machines not earthed adequately.
- Coupling guard used is not suitable.

Maintenance-related causes

- Stipulated maintenance intervals not adhered to.
- Spare parts that were used were not original spare parts from Flender.
- Flender spare parts that were used were old or damaged.
- Leak in the area of the coupling not detected so that chemically aggressive substances damage the coupling.
- Indications of faults, such as noise or vibration, were not heeded.
- Stipulated tightening torques not adhered to.
- Alignment and/or shaft misalignment values not set in accordance with the instructions.

Specific installation-related and maintenance-related causes

- Flexible elements (12) not fitted.
- Fitted flexible elements (12) heated up excessively when applying heat to the coupling parts.
- Flexible elements (12) are of different types or age.
- Flexible elements (12) not replaced as sets.

7.2.3 Correcting faults

7.2.3.1 Replacing wearing parts

Flexible elements (12) are subject to wear and this wear can result in torsional backlash.

Procedure

1. Check the wear on the flexible elements (12) (see section Maximum permissible torsional backlash (Page 44)).
2. Replace the flexible elements (12) if necessary (see section Replacing wearing parts (Page 45)).

7.2.3.2 Correcting the changed alignment

A changed alignment of the coupling during operation often occurs when the coupled machines shift towards one another. A cause of this can be loose foundation bolts.

Procedure

1. Correct the cause for the change in alignment.
2. Check the wearing parts for wear and replace them as required.
3. Check the locking elements that prevent axial movements and correct these as required.
4. Realign the coupling.

8.1 Maintenance intervals



 DANGER
<p>Danger due to bursting of the coupling</p> <p>The coupling can burst if the maintenance intervals are not adhered to. There is a risk of fatal injury from flying fragments. Bursting of the coupling can lead to an explosion in potentially explosive atmospheres.</p> <ul style="list-style-type: none"> • Please observe all the stipulations concerning maintenance of the coupling in this section.



 DANGER
<p>Danger due to bursting of the coupling</p> <p>The coupling can burst if the maximum permitted torsional backlash is exceeded. There is a risk of fatal injury from flying fragments. Bursting of the coupling can lead to an explosion in potentially explosive atmospheres.</p> <ul style="list-style-type: none"> • Note also the actual wear of the elastomer components.



 WARNING
<p>Physical injury</p> <p>Injury from rotating parts.</p> <ul style="list-style-type: none"> • Only carry out work on the coupling when it is not moving. • Secure the drive unit against being operated accidentally. • Attach a notice to the switch stating clearly that work is being carried out on the coupling. • Before starting any work, make sure that the unit is free from loads.

Check the torsional backlash between the coupling parts at the specified maintenance intervals. The maximum permissible torsional backlash for the various coupling sizes can be found in section Maximum permissible torsional backlash (Page 44).

Table 8-1 Maintenance intervals

Type	Initial maintenance	Follow-up maintenance
H	3 months after commissioning	Every 12 months
HDS	3 months after commissioning ¹⁾	Every 12 months ¹⁾

¹⁾ According to the ATEX Directive, need only be inspected if a failure of the flexible elements (12) and shutdown of the drive as a result of this failure could give rise to a risk of explosion. We recommend that the torsional backlash is checked regularly.

Note

Shorter maintenance intervals

If necessary, set shorter maintenance intervals depending on actual wear.

8.2 Maximum permissible torsional backlash

In order to calculate the torsional backlash, rotate one coupling part without applying torque up to the stop. Mark both of the coupling halves in the way shown in the diagram below. Turn the coupling part in the opposite direction up to the stop. The markings on both halves will then move apart. The distance between the markings corresponds to the torsional backlash.

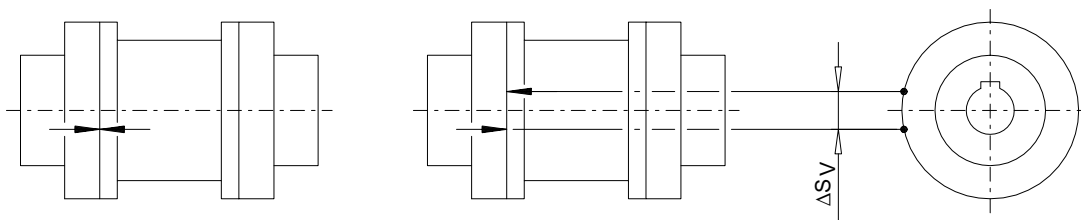

Figure 8-1 Markings for calculating the torsional backlash

Table 8-2 Maximum permissible torsional backlash for the type H (sizes 80 to 200)

Size	80	95	110	125	140	160	180	200
Maximum permissible torsional backlash ΔS_v [mm]	5.0	6.0	7.0	8.0	8.0	8.0	8.0	8.5

Table 8-3 Maximum permissible torsional backlash for the type H (sizes 225 to 440)

Size	225	250	280	315	350	400	440
Maximum permissible torsional backlash ΔS_v [mm]	9.0	10.0	11.5	10.5	11.5	13.0	14.0

Table 8-4 Maximum permissible torsional backlash for the type HDS (sizes 88 to 218)

Size	88	103	118	135	152	172	194	218
Maximum permissible torsional backlash ΔS_v [mm]	5.0	7.0	9.0	10.5	11.5	9.0	8.0	7.0

Table 8-5 Maximum permissible torsional backlash for the type HDS (sizes 245 to 472)

Size	245	272	305	340	380	430	472
Maximum permissible torsional backlash ΔS_v [mm]	6.5	7.0	8.0	6.5	7.0	10.0	12.0

8.3 Replacing wearing parts



DANGER

Danger due to bursting of the coupling

If you do not observe the information stipulated here regarding replacement of wearing parts, this can lead to bursting of the coupling during operation. There is a risk of fatal injury from flying fragments. Bursting of the coupling can lead to an explosion in potentially explosive atmospheres.

- Please observe all the stipulations concerning the replacement of wearing parts.

Replace the flexible elements (12) if the maximum permissible torsional backlash has been reached. It is not necessary to move the coupled machines apart.

Procedure

1. Secure the coupling part 6 (6) in position to prevent it from falling.
2. Loosen the screws (22) between the coupling parts 5 (5) and 6 (6), and between the coupling parts 6 (6) and 7 (7).
3. Press the coupling parts 5 (5) and 7 (7) out of the centring devices using the tapped jacking holes in coupling part 6 (6).
4. Push the coupling part 7 (7) as far as possible into coupling part 1 (1).
5. Remove the coupling part 6 (6) radially.
6. Pull the coupling part 7 (7) out of the coupling part 1 (1).
The flexible elements (12) are now freely accessible.
7. Remove the flexible elements (12).
8. Install the new flexible elements (12).
Please observe the information in section Use and storage of flexible elements (12) (Page 59).

When reinstalling the coupling parts please observe the information in chapters Assembly (Page 23) and Commissioning (Page 35).

8.4 Removing the coupling



 DANGER
Danger from burners and hot coupling parts
Risk of injury due to burners and hot surfaces. Burners or hot coupling parts can lead to an explosion in potentially explosive atmospheres.
<ul style="list-style-type: none">• Wear suitable protective equipment (gloves, safety goggles).• Ensure that the area is not at risk of explosion.

Procedure

1. Secure the coupling parts to prevent them from falling.
2. Loosen the screws (22) between the coupling parts 5 (5) and 6 (6), and between the coupling parts 6 (6) and 7 (7).
3. Press the coupling parts 5 (5) and 7 (7) out of the centring devices using the tapped jacking holes in coupling part 6 (6).
4. Push the coupling part 7 (7) as far as possible into coupling part 1 (1).
5. Remove the coupling part 6 (6) radially.
6. Pull the coupling part 7 (7) out of the coupling part 1 (1).
7. Remove the axial locking elements (set screw, end plate).
8. Use a suitable pulling fixture.
9. Heat up the coupling part 1 (1) and 5 (5) using a burner above the parallel keyway along its length to maximum 80 °C.
Note when doing this the temperature range of the flexible elements (12) (see sections N-EUPEX flexible elements (12) (Page 59) and N-EUPEX DS flexible elements (12) (Page 60)). Remove the flexible elements (12) if necessary.
10. Pull off the coupling part. Use suitable lifting gear when doing this.
11. Check the hub bore and the shaft for damage and protect them against corrosion.
12. Replace any damaged parts.

When reinstalling the coupling parts please observe the information in chapters Assembly (Page 23) and Commissioning (Page 35).

Service and support

9.1 Contact

Contact

When ordering spare parts, requesting a customer service technician or in the case of technical queries, please contact our factory or one of our customer service addresses:

Flender GmbH

Schlavenhorst 100

46395 Bocholt

Germany

Tel.: +49 (0)2871/92-0

Fax.: +49 (0)2871/92-2596

Disposal

Disposal of the coupling

Dispose of the coupling parts according to applicable national regulations or recycle them.

Spare parts

11.1 Ordering spare parts

By stocking the most important spare parts at the installation site you can ensure that the coupling is ready for use at any time.

Note**Original spare parts**

Only use original spare parts from Flender. Flender only accepts liability for original spare parts from Flender.

Other spare parts are not tested and approved by Flender. Non-approved spare parts may possibly change the design characteristics of the coupling and thus impact active and/or passive safety.

Flender will accept no liability or warranty whatsoever for damage occurring as a result of the use of non-approved spare parts. The same applies to any accessories that were not supplied by Flender.

You can find the available spare parts for the coupling described here at Spare parts drawing and spare parts list (Page 52).

You will find our contact data for ordering spare parts in Service and support (Page 47).

Information required when ordering spare parts

- Flender order number with item
- Flender drawing number
- Coupling type and size
- Part number (refer to Spare parts drawing and spare parts list (Page 52))
- Dimensions of the spare part, for example:
 - Bore
 - Bore tolerance
 - Parallel keyway and balancing
- Special dimensions, for example, flange connection dimensions, intermediate sleeve length or brake drum dimensions

- Any special properties of the spare part, such as, for example:
 - Temperature resistance
 - Electrical insulation
 - Operating fluid
 - Use in potentially explosive atmospheres
- Quantity

11.2 Spare parts drawing and spare parts list

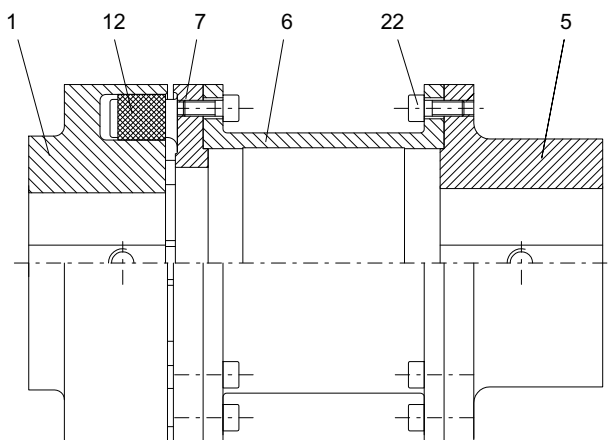

Figure 11-1 Spare parts drawing for types H and HDS

Table 11-1 Spare parts list for types H and HDS

Part number	Designation
1	Coupling part 1
5	Coupling part 5
6	Coupling part 6
7	Coupling part 7
12	Flexible element
22	Cylinder-head screw

Technical data

A.1 Speeds, geometry data and weights

In this section you can find dimension drawings and technical data for N-EUPEX and N-EUPEX DS couplings of the following types:

- Type H (Page 53)
- Type HDS (Page 55)

A.1.1 Type H

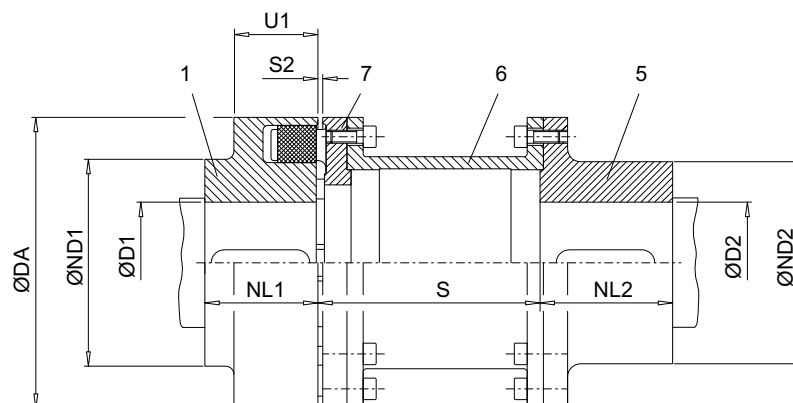

- 1 Coupling part 1
- 5 Coupling part 5
- 6 Coupling part 6
- 7 Coupling part 7

Figure A-1 Type H

Table A-1 Speeds, geometry data and weights of type H

Size	Speed n_{max} rpm	Maximum bore ¹⁾		DA	ND1	ND2	NL1	NL2	S2 +1	S +1	U1	Weight ²⁾ m kg
		D1 mm	D2 mm									
80	6 000	30	32	80	80	55	30	45	5	100	30	2.6
										140		2.7
95	5 500	42	42	95	76	70	35	45	5	100	30	3.5
										140		3.8

Technical data

A.1 Speeds, geometry data and weights

Size	Speed n_{max} rpm	Maximum bore ¹⁾		DA	ND1	ND2	NL1	NL2	S2 +1	S +1	U1	Weight ²⁾	
		D1	D2									m	
		mm	mm									kg	
110	5 300	48	48	110	86	80	40	50	5	100	34	5.2	
								50				140	5.4
								60				180	6
125	5 100	55	55	125	100	90	50	50	5	100	36	7.2	
								50				140	7.7
								60				180	8.2
								70				200	8.5
								80				250	9
140	4 900	60	60	140	100	100	55	65	5	100	34	10	
								65				140	10.5
								65				180	11
								65				200	11.3
								80				250	12
160	4 250	65	65	160	108	108	60	70	6	100	39	13	
								70				140	13.7
								70				180	14.5
								70				200	14.9
								80				250	15.9
180	3 800	75	75	180	125	125	70	80	6	140	42	18.5	
										180		19.4	
										200		21	
										250		22	
200	3 400	85	85	200	140	140	80	90	6	140	47	25.6	
										180		26.5	
										200		27.2	
										250		28.5	
225	3 000	90	90	225	150	150	90	100	6	140	52	34	
										180		35	
										200		36	
										250		38	
250	2 750	100	100	250	165	165	100	110	8	180	60	48	
										200		50	
										250		52	
280	2 450	110	110	280	180	180	110	120	8	250	65	70	
315	2 150	100	120	315	165	200	125	140	8	250	70	98	
		120		200								100	
350	2 000	110	140	350	180	230	140	150	8	250	74	120	
		140			230							125	

Size	Speed n_{max} rpm	Maximum bore ¹⁾		DA	ND1	ND2	NL1	NL2	S2 +1	S +1	U1	Weight ²⁾ m
		D1	D2									
		mm	mm									mm
400	1 700	120	150	400	200	250	160	180	8	250	78	195
		150			250	200						
440	1 550	130	160	440	215	265	180	180	10	250	86	225
		160			265	230						

1) Maximum bore for parallel keyway in accordance with DIN 6885/1.

2) Weight applies to one coupling with maximum bore.

A.1.2 Type HDS

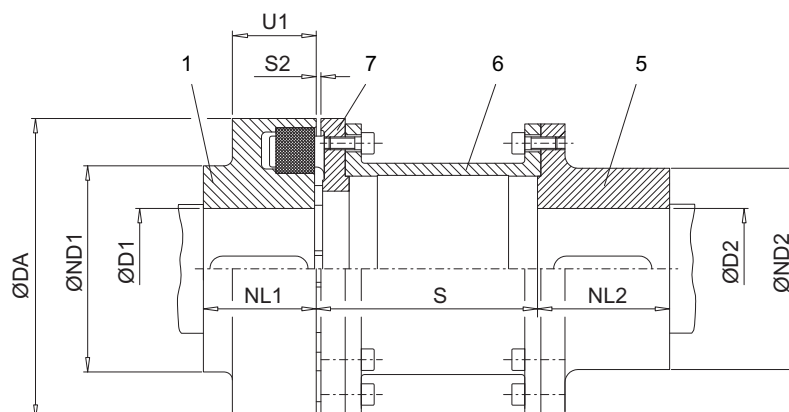

- 1 Coupling part 1
- 5 Coupling part 5
- 6 Coupling part 6
- 7 Coupling part 7

Figure A-2 Type HDS

Table A-2 Speeds, geometry data and weights of type HDS

Size	Speed n_{max} rpm	Maximum bore ¹⁾		DA	ND1	ND2	NL1	NL2	S2 +1	S +1	U1	Weight ²⁾ m
		D1	D2									
		mm	mm									mm
88	6 000	30	32	88	88	55	30	45	5	100	30	2.8
										140		2.9
103	5 500	42	42	103	76	70	35	45	5	100	30	4
										140		4.3

Technical data

A.1 Speeds, geometry data and weights

Size	Speed n_{max} rpm	Maximum bore ¹⁾		DA	ND1	ND2	NL1	NL2	S2 +1	S +1	U1	Weight ²⁾	
		D1	D2									m	
		mm	mm									kg	
118	5 300	48	48	118	86	80	40	50	5	100	34	5.3	
								50				140	5.7
								60				180	6.1
135	5 100	55	55	135	100	90	50	50	5	100	36	7.6	
								50				140	8.1
								60				180	8.6
								70				200	8.9
								80				250	9.4
152	4 900	60	60	152	108	100	55	65	5	100	36	11.2	
								65				140	11.7
								65				180	12.2
								65				200	12.5
								80				250	13.1
172	4 250	65	65	172	118	108	60	70	6	100	41	14.3	
								70				140	15
								70				180	15.9
								70				200	16.2
								80				250	17.2
194	3 800	75	75	194	135	125	70	80	6	140	44	21	
										180		22	
										200		23	
										250		24	
218	3 400	85	85	218	150	140	80	90	6	140	47	30	
										180		31	
										200		32	
										250		33	
245	3 000	90	90	245	150	150	90	100	6	140	52	35	
										180		36	
										200		37	
										250		39	
272	2 750	100	100	272	165	165	100	110	8	180	60	51	
										200		52	
										250		55	
305	2 450	110	110	305	180	180	110	120	8	250	65	74	
340	2 150	120	120	340	200	200	125	140	8	250	70	105	
380	2 000	140	140	380	230	230	140	150	8	250	74	130	
430	1 700	150	150	430	250	250	160	180	8	250	78	205	
472	1 550	160	160	472	265	265	180	180	10	250	86	235	

¹⁾ Maximum bore for parallel keyway in accordance with DIN 6885/1.

2) Weight applies to one coupling with maximum bore.

A.2 Shaft misalignment values during operation

The following table shows the maximum permissible shaft misalignment values ΔS_{2perm} and ΔKr_{perm} . The values are rounded and specified in mm.

Table A-3 Maximum permissible shaft misalignment values during operation

Type / size		Coupling speed [rpm]								
H	HDS	250	500	750	1 000	1 500	2 000	3 000	4 000	5 000
80	88	0.4	0.3	0.25	0.2	0.2	0.15	0.15	0.1	0.1
95	103	0.5	0.35	0.25	0.25	0.2	0.2	0.15	0.1	0.1
110	118	0.5	0.35	0.3	0.25	0.2	0.2	0.15	0.1	0.1
125	135	0.5	0.4	0.3	0.25	0.25	0.2	0.15	0.15	0.1
140	152	0.6	0.4	0.35	0.3	0.25	0.2	0.2	0.15	
160	172	0.6	0.5	0.4	0.35	0.3	0.25	0.2	0.15	
180	194	0.6	0.5	0.4	0.35	0.3	0.25	0.2		
200	218	0.8	0.55	0.45	0.4	0.3	0.3	0.2		
225	245	0.8	0.55	0.5	0.4	0.35	0.3	0.25		
250	272	0.8	0.6	0.5	0.4	0.35	0.3			
280	305	1	0.7	0.6	0.5	0.4	0.35			
315	340	1	0.7	0.6	0.5	0.4	0.35			
350	380	1	0.8	0.6	0.6	0.5				
400	430	1.2	0.9	0.7	0.6	0.5				
440	472	1.3	1	0.7	0.7	0.6				

You can calculate the numerical values in the table and their intermediate values as follows:

$$\Delta Kr_{perm} = \Delta S_{2perm} = (0.1 + DA / 1000) \cdot 40 / \sqrt{n}$$

DA in mm (see Speeds, geometry data and weights (Page 53))

Radial misalignment ΔKr_{perm} in mm

The values in column "250 rpm" of the table above apply for speeds of < 250 rpm.

A.3 Tightening torques and widths A/F

Table A-4 Tightening torques for part 22 of types H and HDS

N-EUPEX- Coupling	N-EUPEX DS- Coupling	Tightening torque T_A and width A/F SW for Hexagon socket-head screws according to DIN EN ISO 4762	
		T_A Nm	SW mm
80	88	13	5
95	103	13	5
110	118	14	6
125	135	17.5	6
140	152	29	8
160	172	35	8
180	194	44	8
200	218	67.5	10
225	245	86	10
250	272	145	14
280	305	185	14
315	340	200	14
350	380	260	17
400	430	340	17
440	472	410	17

Apply the recommended tightening torques in accordance with the stipulations in section Tightening procedure (Page 58).

A.4 Tightening procedure

Tighten fastening screws to the specified tightening torque in accordance with the following table:

Table A-5 Tightening procedure

Scatter of the torque applied at the tool	Tightening procedure (As a rule, the tightening procedures listed are within the specified tool torque scatter)
±5 %	<ul style="list-style-type: none"> Hydraulic tightening with mechanical screwdriver Torque-controlled tightening with a torque wrench or a torque wrench that gives a signal Tightening with a precision mechanical screwdriver with dynamic torque measurement

The tightening torques apply to screws/bolts with untreated surfaces that are not oiled or are only lightly oiled, and for screws/bolts that are used with a liquid screw locking agent in accordance with these instructions. Use with lubricant paint or lubricant is not permitted.

A.5 Flexible elements (12)

A.5.1 Use and storage of flexible elements (12)

Note the following concerning the use and storage of the flexible elements (12):

- Storage possible for up to 5 years
- Protect against direct sunlight, artificial light with a high UV-content and extreme temperatures
- Avoid contact with aggressive media
- Only replace complete sets
- Only use flexible elements of the same type and age

A.5.2 N-EUPEX flexible elements (12)

Table A-6 N-EUPEX flexible elements

Material	Hardness	Comment	Marking	Ambient temperature	Approved for explosion group
NBR	80 Shore A	Standard	Black flexible elements with blue stripe	-30 °C to +80 °C	IIA, IIB, IIC
NBR	65 Shore A	Special, soft, shifting of the resonant speed, rated torque reduced	Black flexible elements with green stripe	-30 °C to +80 °C	IIA, IIB, IIC
NBR	90 Shore A	Special, hard, shifting of the resonant speed	Black flexible elements with magenta stripe	-30 °C to +80 °C	IIA, IIB, IIC
NBR	80 Shore A	Special, increased (low-backlash)	Black flexible elements with yellow stripe	-30 °C to +80 °C	IIA, IIB, IIC
NBR	65 Shore A	Special, increased (low-backlash) shifting of the resonant speed, rated torque reduced	Black flexible elements with white stripe	-30 °C to +80 °C	IIA, IIB, IIC
NR	80 Shore A	Special, low-temperature use	Black flexible elements with orange stripe	-50 °C to +50 °C	IIA, IIB, IIC

Technical data

A.5 Flexible elements (12)

Material	Hardness	Comment	Marking	Ambient temperature	Approved for explosion group
HNBR	80 Shore A	Special, high-temperature use	Black flexible elements with red stripe	-10 °C to +100 °C	Not approved
NBR	80 Shore A	Special, electrically insulating	Green flexible elements	-30 °C to +80 °C	IIA, IIB

A.5.3 N-EUPEX DS flexible elements (12)

Table A-7 N-EUPEX DS flexible elements

Material	Hardness	Comment	Marking	Ambient temperature	Approved for explosion group
NBR	80/90 Shore A	Standard, 2 components Sizes 66 ... 272	Black flexible elements	-30 °C to +80 °C	IIA, IIB, IIC
NBR	90 Shore A	Standard, sizes 305 ... 556	Black flexible elements	-30 °C to +80 °C	IIA, IIB, IIC
PU	95 Shore A	Special, electrically insulating	Blue flexible elements / green flexible elements	-30 °C to +50 °C	IIA, IIB

Quality documents

B.1 Declaration of Conformity

EU declaration of conformity

Product:
FLENDER N-EUPEX® and
FLENDER N-EUPEX-DS®
couplings
Types H and HDS

Name and address of the manufacturer:

Flender GmbH
Schlavenhorst 100
46395 Bocholt
Deutschland – Germany

This declaration of conformity is issued under the sole responsibility of the manufacturer.

Object of the declaration is the product specified above.

The object of the declaration described above is in conformity with the relevant harmonisation legislation of the Union:

– Directive 2014/34/EU Official Journal L 96, 29.3.2014, pages 309-356

Harmonised standards or other technical specifications, on which the declaration of conformity is based:

EN 1127-1 : 2011
EN 1710 : 2008
EN 13463-1 : 2009
EN 13463-5 : 2011

The notified body, DEKRA EXAM GmbH, code number 0158, has received the technical documentation.

Signed for and on behalf of:
Flender GmbH



Bocholt, 2017-10-01

i.V.

Felix Henseler, Head of PD MD AP

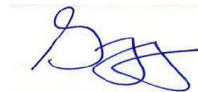

Bocholt, 2017-10-01

i.V.

Thomas Tebrügge, Head of PD MD AP COU BA

FLENDER COUPLINGS

N-EUPEX / N-EUPEX DS
Operating Instructions 3101en
Edition 10/2017

Flender GmbH
Alfred-Flender-Straße 77
46395 Bocholt
GERMANY